

Instruction Manual and Spare Parts Catalog

➤ JUNIOR II

JUNIOR II-B
JUNIOR II-E
JUNIOR II-W



INTRODUCTION

This manual contains operating instructions and maintenance schedules for the high pressure breathing air compressor unit

Junior II

WARNING

! Pneumatic high pressure system !

The breathing air produced with the compressor units described in this manual is subject to strict quality standards. Ignoring the operating and maintenance instructions can lead to severe injury or death.

This compressor has been built in accordance with the EC machine regulations 2006/42/EG. Specifications on the noise level in accordance with the machine and product safety law as of 01.05.2004 and the EC machine regulations, chapt. I, section 1.7.4. The machine has been built according to the highest standard of technology and the generally acknowledged safety standards. Nevertheless, operation could still cause danger for the operating personnel or third parties, or result in damage to the machine and other values. The machine may only be used to produce compressed air as specified in this manual. Other use is strictly prohibited.

All instructions should be observed and carried out in the order laid down to prevent damage and premature wear to the equipment.

The manufacturer and the supplier void all responsibility for damage or injury resulting from failure to follow these instructions.

Edition October 2013

© 2013 BAUER Kompressoren GmbH, München

All rights reserved

Original language: german

Dear customer

We are happy to give you advice on any questions regarding your **BAUER** compressor and help as soon as possible with any arising problems.

You can contact us Mondays to Thursdays from 08⁰⁰ till 16³⁰, Fridays from 08⁰⁰ till 14⁰⁰ on phone no. (089) 78049-0.

If you call the following extensions directly, it will save you time and continuous dialling.

Do you want to order spare parts?

Customer service

Phone no: (089) 78049-129 or -149

Fax no: (089) 78049-101

Do you have problems with maintenance or repair work?

Technical customer service

Phone no: (089) 78049-246 or -176

Fax no: (089) 78049-101

Do you need further information regarding your unit, accessories, prices etc.?

Sales department

Phone no: (089) 78049-138, -185, -154, -205 or -202

Fax no: (089) 78049-103

Are you interested in any training courses?

Training manager

Phone no: (089) 78049-175

Fax no: (089) 78049-103

Explanation of the short operating instructions on the unit

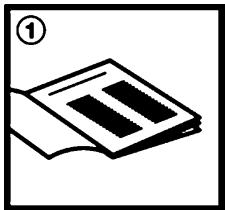

Read instruction manual before operating unit

☞ chapter 3.

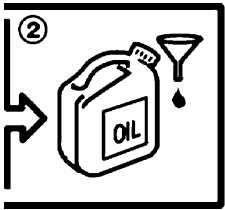

Check oil level on compressor and petrol engine before operating unit

☞ chapter 4.4.1.

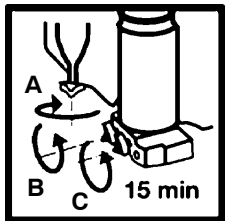

Drain condensate at least every 15 minutes (3 locations)

☞ chapter 4.4.3. and 4.4.4.

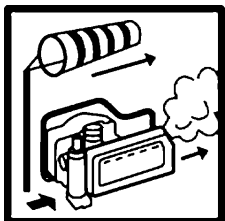

Position units with petrol engine with exhaust in wind direction to prevent exhaust fumes being sucked in by the compressor

☞ chapter 3.

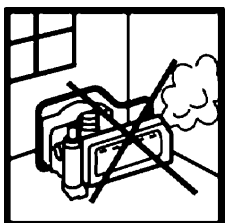

Petrol driven units must not be operated indoors.

☞ chapter 3.

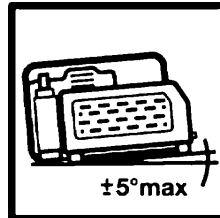

Position unit level: max. inclination 5°

☞ chapter 3.

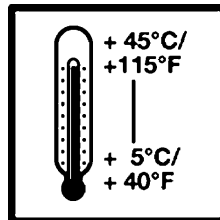

Operate unit only at ambient temperatures between +5 and +45 °C

☞ chapter 3.



Keep away from hot surfaces on motor and compressor

☞ chapter 2.

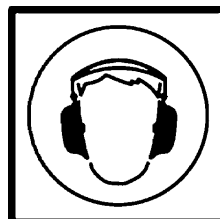

Wear ear protectors when unit is running

☞ chapter 2.

CONTENTS

1.	GENERAL	1
2.	SAFETY MEASURES	7
3.	LOCATION, OPERATION, BOTTLE FILLING ..	11
4.	MAINTENANCE	20
5.	STORAGE, PRESERVATION	37
6.	REPAIR INSTRUCTIONS	38
7.	TABLES	39
8.	ANNEX	41

INDEX

A

Air flow diagram, 4
Automatic condensate drain, 30

B

B-Timer, 16

C

Change-over device, 15
Cooling system, 34

D

Dispose of condensate, 31
Drive system, 30

E

Electrical system, 32

F

Filling procedure, 13
Filter system, 22

I

Intake filter, 21
Intermediate separator, 21
Intake air quality, 13

L

Location, 11
Lubrication, 20

M

Maintenance, 20
Motor protection switch, 32

O

Oil change, 20, 21
Operation, 11

P

Preservation, 37
Pressure gauge, 27
Pressure switch, 33
Pressure-maintaining valve, 27

R

Repair instructions, 38

S

Safety valves, 27
Shut-down, 15
Storage, 37

T

Tables, 39
Technical data, 5
Telescopic intake tube, 21
Trouble-shooting, 35

V

Valves, 28

ANNEX

Schematic diagram motor protection switch, three phase current	76942-S1
Schematic diagram compressor with controller, three phase current	e_02380414
Schematic diagram compressor with controller, alternating current	e_02380366
Lubricating oil list	70851
Applicable parts list	TJ-5/0

NOTES

Model:

Serial No.:

Date of purchase:

Dealer address / phone no.:

.....

.....

.....

.....

.....

.....

.....

.....

.....

.....

.....

.....

.....

.....

.....

.....

.....

.....

.....

.....

.....

.....

.....

.....

.....

.....

.....

.....

.....

.....

.....

.....

.....

.....

.....

.....

.....

.....

.....

.....

.....

.....

.....

1. GENERAL

PURPOSE

The **JUNIOR II** breathing air compressor is designed to compress air for breathing as required in diving applications. The max. allowable operating pressure (adjusted pressure on final pressure safety valve) is 225 bar or 330 bar.

DESIGN

The compressor unit comprises the following major assemblies:

- compressor block
- drive motor
- filter system P21
- filling assembly
- base plate and frame
- automatic condensate drain unit^{a)}
- Compressor controller^{a)}
- Change-over device PN200/PN300^{a)}

The design of the compressor system is shown in Fig. 1 to Fig. 5.

- 1 Filling valve with pressure gauge, PN200
- 2 Filling valve with pressure gauge, PN300
- 3 Final pressure safety valve, PN300
- 4 Final pressure switch, PN200
- 5 Final pressure switch, PN300
- 6 Condensate separator/silencer
- 7 Condensate drain valve, last stage
- 8 Condensate drain tap
- 9 Condensate drain valve, 2nd stage
- 10 Final pressure safety valve, PN200
- 11 Pressure maintaining valve
- 12 Change-over valve
- 13 B-Timer
- 14 Filter system P21
- 15 V-belt cover
- 16 Compressor controller

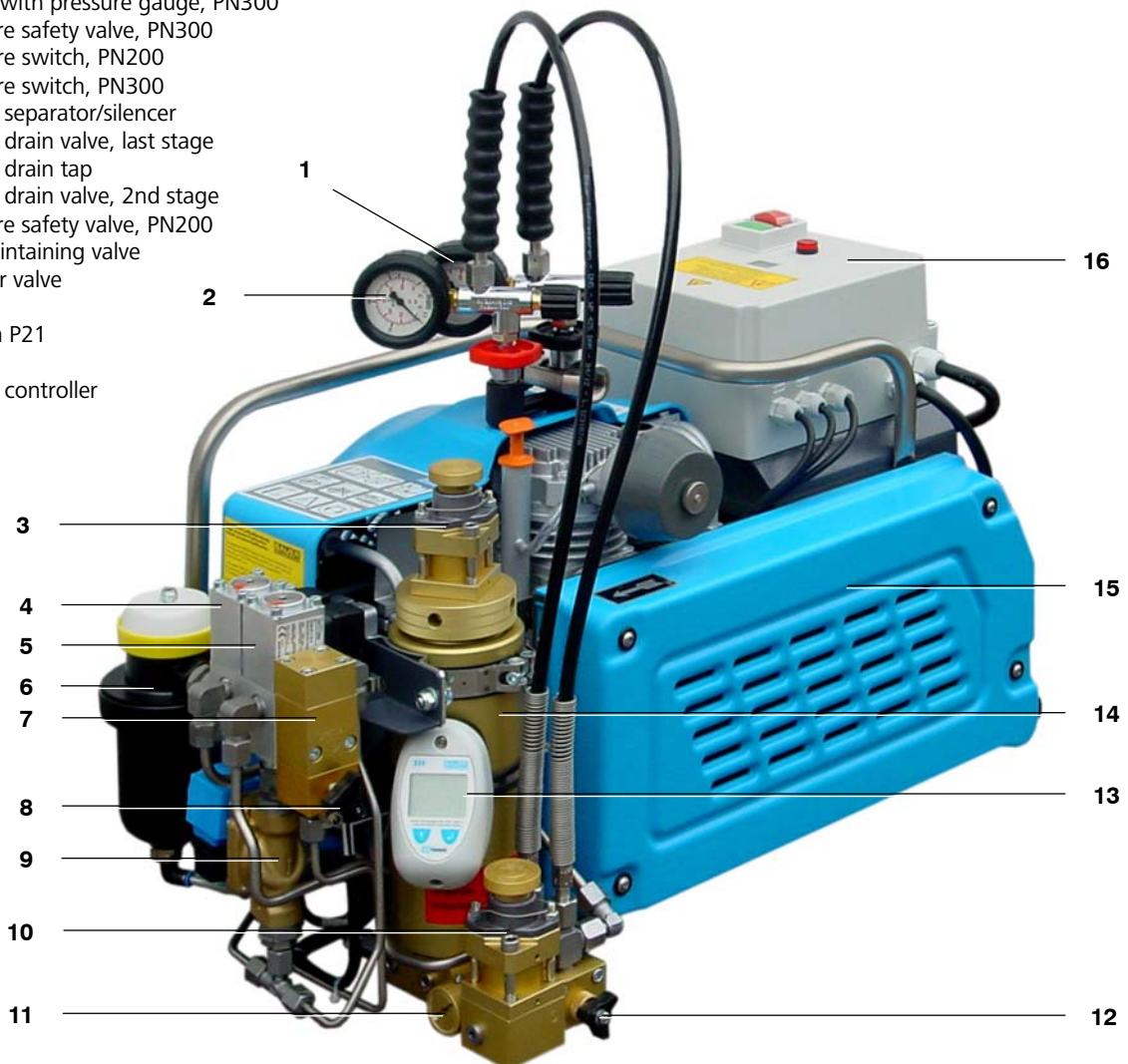

Fig. 1 Compressor unit with electric motor, automatic condensate drain unit and change-over device

a) Option

- 1 Filling hose
- 2 Exhaust
- 3 Air filter
- 4 Tank
- 5 Throttle lever
- 6 Choke lever
- 7 Fuel cock
- 8 Starter rope
- 9 Engine stop switch (ignition)
- 10 Filling valve with final pressure gauge
- 11 Safety valve, final pressure
- 12 Filter system P21
- 13 Final pressure switch
- 14 Condensate drain valve, last stage
- 15 Condensate drain valve, 2nd stage
- 16 Condensate separator/silencer
- 17 Timer

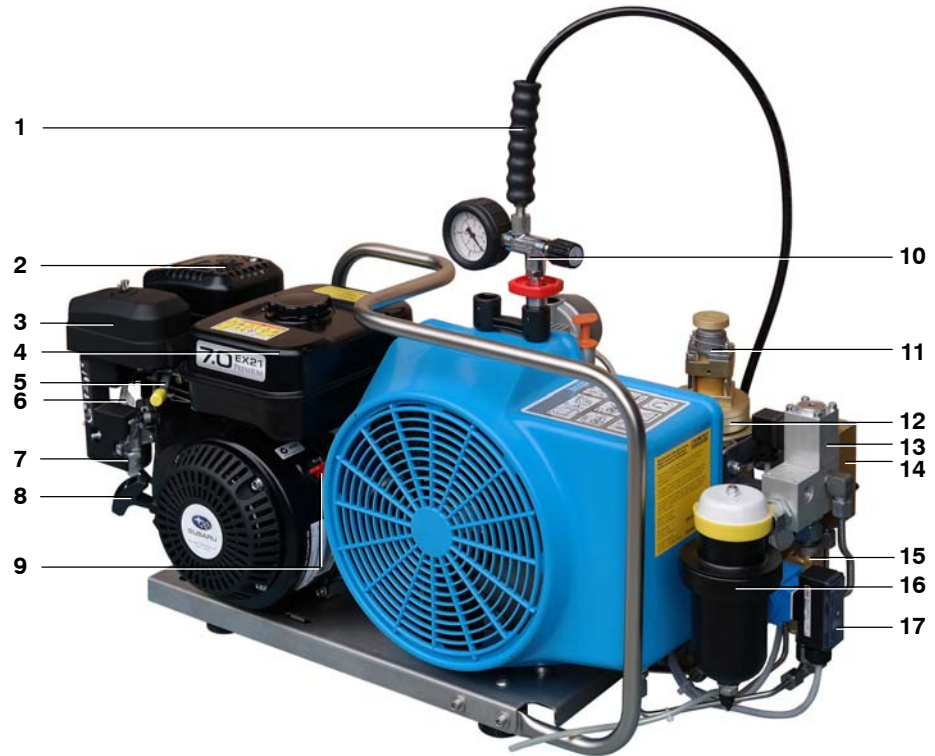

Fig. 2 Compressor unit with petrol engine and automatic condensate drain unit

- 1 Filling hose
- 2 Filling valve with final pressure gauge
- 3 Compressor controller
- 4 Electric motor
- 5 Fanwheel cover
- 6 Safety valve, final pressure
- 7 Final pressure switch
- 8 Condensate drain valve, last stage
- 9 Condensate drain valve, 2nd stage
- 10 Condensate separator/silencer



Fig. 3 Compressor unit with electric motor and automatic condensate drain unit

- 1 Filling hose
- 2 Filling valve with pressure gauge
- 3 Motor terminal box
- 4 Three-phase motor
- 5 Final pressure safety valve
- 6 Handle
- 7 Fanwheel cover
- 8 B-Timer
- 9 Condensate drain valves
- 10 Mains plug with ON-OFF switch and motor protection circuit breaker (dep. on country)

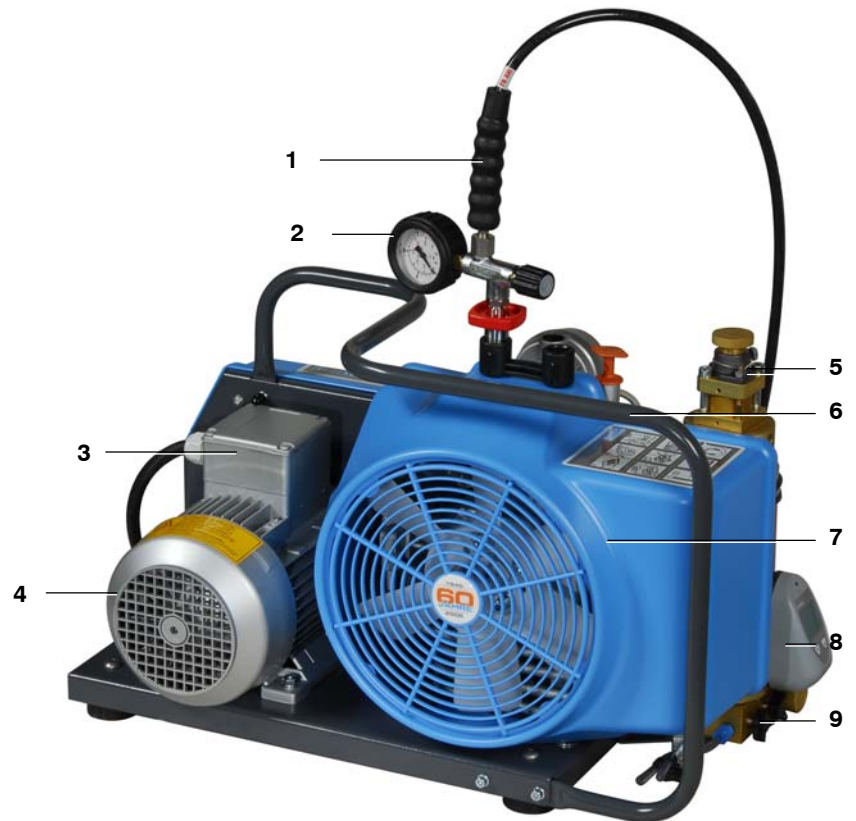

Fig. 4 Compressor unit with electric motor (three-phase current)

- 1 Filling hose
- 2 Filling valve with pressure gauge
- 3 Motor terminal box with ON-OFF switch
- 4 Single-phase motor
- 5 Final pressure safety valve
- 6 Handle
- 7 Fanwheel cover
- 8 Pressure maintaining valve
- 9 Condensate drain valves



Fig. 5 Compressor unit with electric motor (alternating current)

AIR FLOW DIAGRAM

See Fig. 6 . The air is drawn in through telescopic tube (necessary for units with petrol engine), intake filter A3; compressed to final pressure in cylinders B1, B2, B3; recooled by intercoolers W1, W2, and aftercooler W5. The pressures of the single stages are protected by safety valves U1, U2, U5.1. The compressed air is pre-cleaned in intermediate separator -8 and purified in filter system P21 (D5 + D13). Intermediate separator D2 and filter system P21 are drained by means of condensate drain taps V5. Pressure maintaining valve R7 provides a constant pressure within the filter assembly. The compressed, purified air is passed through filling hose Z21 and filling valve V3 or V2 to the bottles to be filled. Filling pressure is indicated at pressure gauge P12. With the change-over de-

vice it is possible to fill bottles with 200 bar nominal pressure, just by opening valve V9 at filling valve V2. Safety valve U5.2 is adjusted to a blow off pressure of 225 bar.

On models with automatic stop device, final pressure switch F16 stops the compressor by reaching the adjusted filling pressure.

On models with automatic condensate drain unit, filters are regularly drained through solenoid valve Y2 and condensate drain valve C2 during operation. Condensate drain tap V5.4 is used to drain manually the filter system P21. The drained air is separated from condensate in separator D11 and lead back to the atmosphere through silencer Z3.1.

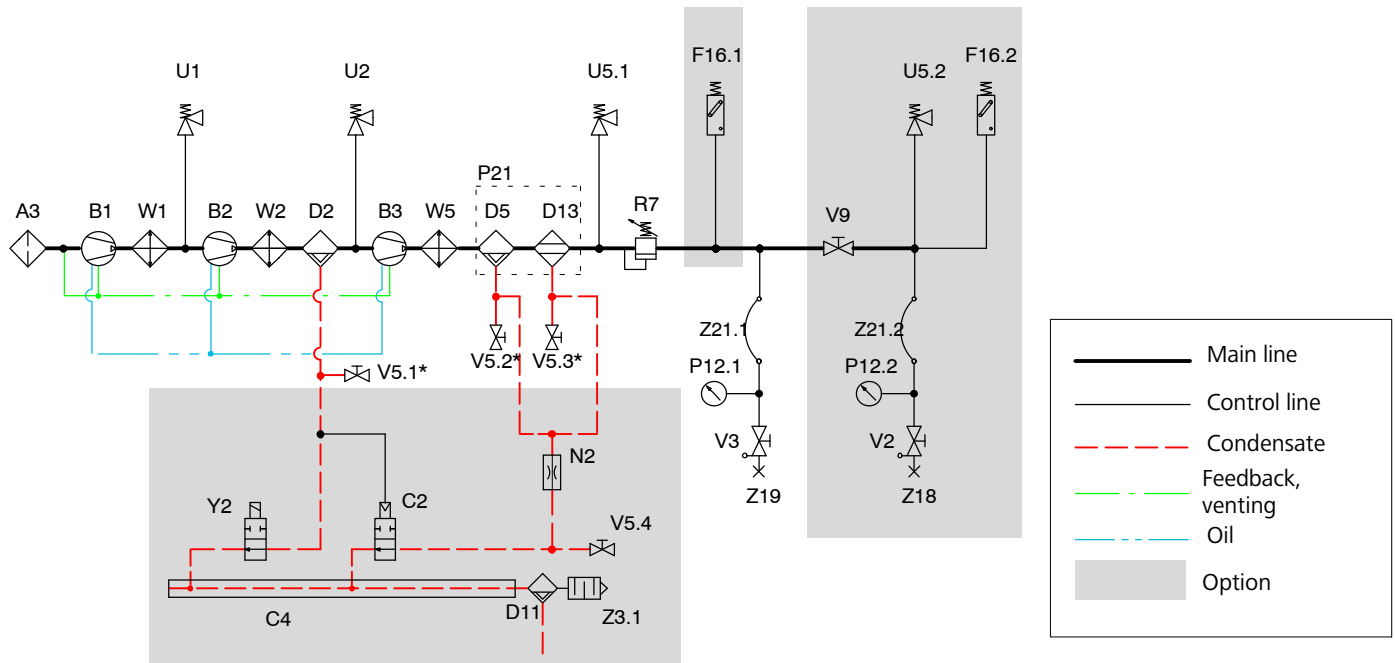

Fig. 6 Air flow diagram

- A3 Intake filter
- B1 Cylinder 1st stage
- B2 Cylinder 2nd stage
- B3 Cylinder 3rd stage
- C2 Condensate drain valve 3rd stage
- C4 Condensate manifold
- D2 Intermed. separator 2nd stage
- D5 Oil and water separator
- D11 Condensate separator
- D13 Purifier
- F16.1 Final pressure switch, PN300
- F16.2 Final pressure switch, PN200
- N2 Nozzle
- P12.1 Pressure gauge PN300
- P12.2 Pressure gauge PN200
- P21 Triplex filter system
- R7 Pressure maintaining valve

- U1 Safety valve 1st stage
- U2 Safety valve 2nd stage
- U5.1 Final pressure safety valve PN300
- U5.2 Final pressure safety valve PN200
- V2 Filling valve, PN300
- V3 Filling valve, PN200
- V5.X Condensate drain tap
- V9 Change-over valve PN200/PN300
- W1 Inter-cooler 1st stage
- W2 Inter-cooler 2nd stage
- W5 After-cooler
- Y2 Condensate drain valve 2nd stage
- Z3.1 Silencer
- Z18 Filling connector, PN200
- Z19 Filling connector, PN300
- Z21 Filling hose

* On units without automatic condensate drain only

TECHNICAL DATA

Compressor unit	JuniorII-B	JuniorII-E	JuniorII-W
Medium	breathing air		
Intake pressure	atmospheric		
Delivery ^{a)}	100 l/min. (3,5 Scfm, 6 m ³ /h)		
Operating pressure	PN200/PN300		
Pressure setting, final pressure safety valve	225/330 bar		
Pressure setting, pressure maintaining valve	160 bar		
Sound (immersion) power	97 dBA)	95 dB(A)	
Dry weight, max.	52 kg	53 kg	53 kg
Dimensions (LxBxH), standard unit	760x410x415 mm	655x360x415 mm	655x360x415 mm
Dimensions (LxBxH), Anlage with automatic condensate drain	880x410x415 mm	760x430x480 mm	760x430x480 mm
Compressor block	Junior, mod. 3		
Number of stages	3		
Number of cylinders	3		
Cylinder bore 1st stage	60 mm		
Cylinder bore 2nd stage	28 mm		
Cylinder bore 3rd stage	12 mm		
Piston stroke	24 mm		
Speed	2,300 min ⁻¹		
Intermediate pressure 1st stage	6-7 bar		
Pressure setting, safety valve 1st stage	10 bar		
Intermediate pressure 2nd stage	40-60 bar		
Pressure setting, safety valve 2nd stage	80 bar		
Compressor block oil capacity	360 ml		
Oil volume between min. and max. marks	50 ml		
Oil type	see chapter 4.4.1. lubrication		
Max. ambient temperature	+5 ... +45 °C		
Air outlet temperature	ambient temperature + 20 °C		
Max. inclination of compressor ^{b)}	5°		
Max. operating height	0 ... 1500 m above sea level		
Compressor drive	JuniorII-B	JuniorII-E	JuniorII-W
Drive motor	Petrol engine	Three phase current motor	Alternating current motor
Power	4,2 kW (5,7 PS)	2,2 kW (3 PS)	2,2 kW (3 PS)
at nominal speed	3.600 min ⁻¹	2.900 min ⁻¹	2.850 min ⁻¹
Operating voltage	—	400 V, 50 Hz	230 V, 50 Hz
Nominal current	—	4.6 A (400V/50Hz)	13.2 A (230V/50Hz)
Type of enclosure	—	IP55	IP55
Size	—	A90 L	A90 L
Type of construction	—	B3	B3

a) free air delivered at bottle filling from 0 to 200 bar ±5%

b) these values are valid only if the oil of the compressor in normal position corresponds with the upper mark of the oil dipstick and may not be exceeded.

Compressor unit	JuniorII-B	JuniorII-E	JuniorII-W
Filter system	P21		
Residual moisture content	< 10 mg/m ³		
Residual oil content	< 0,1 mg/m ³		
Pressure dew point	-20°C, corresponds to 3 mg/m ³ at 300 bar		
Filter capacity	0,57 l		
Automatic condensate drain unit	Scuba diving version		
Type	dual		
Control voltage	24 VDC		
Intervall switching (closed / open)	15 min / 6 sec		

c) Option

2. SAFETY MEASURES

2.1. NOTES AND WARNING SIGNS

Notes and warning signs displayed on compressors according to model, application or equipment.



WARNING

Hot surfaces, do not touch!

Danger of burning by touching cylinders, cylinder heads and pressure lines of individual compressor stages.



WARNING

High voltage!

Life threatening danger of electric shock. Maintenance work on electric units or operating equipment may only be carried out by a qualified electrician or by a person instructed and supervised by a qualified electrician according to electrical regulations.



WARNING

Automatic compressor control, unit may start-up without warning!

Before carrying out maintenance and repair work, switch off at the main switch or disconnect from the mains and ensure unit will not restart.



MANDATORY

Instructions must be read by persons operating the machinery!

The instruction manual supplied and all other applicable instructions, regulations etc. must be read and understood by operating personnel before using the machine.



MANDATORY

Hearing protectors must be worn!

Hearing protectors must be worn when working on a machine which is running.

NOTE



Ensure correct direction of rotation!

When switching on the machine, check the arrow to ensure correct direction of rotation of the drive motor.

2.2. IDENTIFYING THE SAFETY NOTICES

Important instructions concerning the endangerment of personnel, technical safety and operating safety will be specially emphasized by placing the following signs before the instructions.



This notice is used with maintenance work and operating procedures and must be adhered to exactly in order to avoid endangering personnel.



This notice must be complied with in order to avoid damage to or destruction of the machine or its equipment.



This notice advises of technical requirements which the operator must take particular note of.

2.3. FUNDAMENTAL SAFETY NOTICES

2.3.1. Authorized use

- The machine / unit is built according to state of the art technology and established safety technical regulations. Nevertheless, its use can cause danger to life and limb of the operator or third parties or damage to the machine and other equipment.
- Operate the machine / unit only in technically perfect condition in accordance with regulations and safety and danger notices detailed in the instruction manual! In particular, immediately correct faults (or have them corrected) which can impair safety!
- The machine / unit is exclusively for the compression of mediums (air/gas) specified in section A, chapter 1.3. "Technical data". Any other medium or use outside that specified is not authorized. The manufacturer / supplier is not liable for damage resulting from this. The user alone is responsible for this risk. Authorization for use is also under the condition that the instruction manual is complied with and inspection and maintenance requirements are enforced.

2.3.2. Organizational measures

- Keep the instruction manual to hand near the machine / unit at all times in the relevant holder.
- In addition to the instruction manual, observe and comply with universally valid legal and other obligatory regulations regarding accident prevention and environment protection. See chapter 2.4. This can involve, for example, contact with hazardous substances or the provision / wearing of personal protective equipment.
- Personnel engaged to operate the machine must have read the instruction manual before beginning work, es-

pecially the safety notices chapter. When work is already underway it is too late. This is particularly relevant for temporary personnel, e.g. maintenance personnel.

- Personnel may not wear long hair loose, loose clothing or jewellery, including rings. There is a danger of injury through, for example, these getting caught or being pulled into the equipment.
- As far as necessary or according to regulations, use personal protective equipment.
- Observe all safety and danger notices on the unit.
- Keep all safety and danger notices on the machine / unit complete and in readable condition.
- If there are any modifications to the unit or operating conditions which may affect safety, stop the unit immediately and inform the person responsible of the fault.
- No modifications may be made to the unit which could impair safety without first obtaining permission from the suppliers. This is also the case with regard to installation and adjustment of safety devices and valves as well as welding of piping and reservoirs.
- Spare parts must always comply with the technical requirements specified by the manufacturer. This is always guaranteed with original spare parts.
- Piping must be thoroughly checked (pressure and visual inspection) by the operator at appropriate time intervals, even if no safety related faults have been noticed.
- Intervals stipulated or given in the instruction manual for recurring checks / inspections must be adhered to.
- Make sure location and operation of fire extinguishers is known.
- Pay attention to fire warning and fire fighting procedures.

2.3.3. Qualifications, fundamental duties

- Work on / with the unit may only be carried out by reliable personnel. Observe the legal minimum age permissible.
- Ensure that only trained personnel work with the machine.
- Establish the responsibilities of the machine operator and establish a procedure for him to inform a third person of unfavourable safety conditions.
- People who are being trained or introduced to the job should only be allowed to work with the unit under constant supervision of an experienced person.
- Work on the electrical equipment of the unit may only be carried out by a qualified electrician or by an instructed person under the direction and supervision of a qualified electrician according to electrotechnical regulations.

2.3.4. Safety notices for operation

- Do not carry out any work if safety is questionable.
- Meet all requirements demanding that the unit is only operated in safe and good working order. Only operate the machine if all protective and safety equipment, e.g. all detachable protective equipment, emergency shut-down

devices, soundproofing is provided and in good working order.

- At least once every day, check the unit externally for damage and faults. Inform the person responsible immediately if anything is not as it should be (including operation). If necessary, shut the machine down immediately and make it safe.
- Observe switching on and off processes and monitoring indications according to the instruction manual.
- Before switching on / starting up the unit, ensure that no one can be put at risk through running the unit.
- Carry out the setting, maintenance and inspection processes at the intervals specified in the instruction manual, including replacement of parts / equipment. This work may only be carried out by qualified personnel.
- Clear and make the maintenance area safe as far as necessary.
- If the unit is completely switched off for maintenance and repairwork, ensure that it is protected from unexpected start-up. Turn off main control device and remove the key and / or display a warning sign on the main switch.
- When replacing individual parts and larger assembly groups, they must be carefully fastened to the lifting device so that there is no risk of danger. Use only suitable and technically perfect lifting devices and equipment with sufficient lifting power and strength. Do not linger or work under suspended loads.
- Only entrust an experienced person with the fixing of loads and guiding of crane drivers. The person guiding must remain within sight or in contact with the operator.
- For assembly work above body height, use appropriate safety approved equipment, e.g. ladders and platforms. Do not climb on machine parts. For maintenance work at high levels, wear a safety harness.
- Clean oil, fuel or care products from the machine, in particular the connections and screw joints, before carrying out maintenance / repairwork. Do not use aggressive cleaning fluid. Use a fibre-free cleaning cloth.
- Before cleaning the machine with water or jet of steam (high pressure cleaner) or detergent, cover / seal all openings which for safety and/or operating reasons no water / steam / detergent may penetrate. Electric motor and switch cabinets are particularly at risk.
- When cleaning the operating room, ensure that the temperature sensors of the fire alarm and sprinkler system do not come into contact with hot cleaning fluid, in order to avoid triggering the sprinkler system.
- Completely remove all covers / seals after cleaning.
- After cleaning, check all pressure lines for leaks, loose connections, wear and damage. Immediately eliminate any faults.
- Always retighten any screw connections loosened for maintenance or repairwork.
- If it is necessary to remove safety devices for maintenance and repairwork, these must be replaced and checked immediately after completion of the maintenance or repairwork.

- Ensure safe and environmentally friendly disposal of consumables and old parts.

2.3.5. Particular areas of danger

- Use only original fuses with specified current rating. If there is a failure in the electric energy supply, shut the unit down immediately.
- Work on electric units or operating equipment may only be carried out by a qualified electrician or by a person under the instruction and supervision of a qualified electrician according to electric technical regulations.
- Machines and unit parts which must undergo inspection, maintenance and repairwork, must be disconnected from the mains supply, if specified. Parts which have been disconnected must first be checked for voltage, then earthed and short-circuited and isolated from live neighbouring parts.
- The electrical equipment of a unit must be regularly checked. Defects, such as loose screw connections or burnt wires, must be rectified immediately.
- If work is to be carried out on live parts, work with a second person who can operate the emergency off switch or the main switch in the case of an emergency. Close off the work area with a red and white safety chain and a warning sign. Only use voltage isolated tools.
- Only personnel with particular knowledge and experience with pneumatics may carry out work on pneumatic equipment.
- Check all pressure lines, hoses and screw connections regularly for leaks and visible damage. Immediately repair any damage. Escaping air under pressure can cause injury and fire.
- Depressurize system and pressure lines before commencing repairwork.
- Pressurized air lines must be laid and mounted by qualified personnel. Connections must not be mixed up. Fittings, length and quality of the piping must correspond to requirements.
- Soundproofing equipment on the unit must be in place and functional during operation.
- The stipulated hearing protectors must be worn.
- With regard to oil, grease and other chemical substances, observe the relevant safety regulations for the product.
- For loading, only use lifting device and equipment with sufficient lifting power and strength.
- Use only suitable transporters with sufficient carrying power. Secure the load properly. Use suitable fixing points.
- If necessary, provide unit with transportation brackets. Display the appropriate notice. Remove transportation brackets in the correct manner before taking into operation.
- Parts which need to be dismantled for transport purposes must be carefully replaced and secured before taking into operation.

- Even when moving the unit only slightly, the unit must be disconnected from all external energy sources. Before putting into use again, reconnect the machine to the mains according to regulations.
- When taking back into operation, proceed according to the instruction manual.

2.3.6. Notices of danger regarding pressure vessels

- Never open or loosen pressure vessel lids or pipe connection parts under pressure; always depressurise the vessel or the unit.
- Never exceed the permissible operating pressure of the vessels!
- Never heat the vessels or any of their parts above the stated, maximum operating pressure.
- Always exchange damaged pressure vessels completely. Individual parts that are subject to pressure loads cannot be purchased as spare parts, since the vessels are tested as a complete part and the documentation considers them as a whole (see pressure vessel documentation, serial-numbers!).
- Always pay attention to the permissible operating mode of the pressure vessels.

We differentiate:

- vessels for static load
- vessels for dynamic load

Vessels for static load:

These pressure vessels are permanently under virtually constant operating pressure; the fluctuations of pressure are very small.

Vessels for this type of load are not marked in a particular way and may be used as long as the vessel inspections, carried out regularly, do not uncover any safety-relevant deficiencies.

We recommend that aluminium vessels should be exchanged after 15 years at the latest.

Vessels for dynamic load:

These pressure vessels may also be used under conditions of changing operating pressure. The pressure may vary between the atmospheric and the maximum admissible operating pressure.

The pressure vessel documentation and the appropriate notes in the operating manual particularly characterise vessels of this type as being adequate for dynamic loads. In the technical information for these vessels you will find specifications concerning their permissible operating period.

Due to the variation of the operating pressure, these vessels are subject to a so-called dynamic load, which puts the vessels under great stress. The change between two different pressures is called a load change or cycle. In the technical information for these vessels you will find specifications concerning the permissible number of cycles depending on the fluctuation of the operating pressure.

Having reached half the permissible number of cycles, the vessel has to be submitted to an internal check, in which

the critically stressed areas of the vessels are examined by means of suitable testing methods, in order to ensure the operating safety.

After having reached the total permissible number of load cycles, the vessel must be exchanged and scrapped. Record the number of load cycles in writing if you do not have an automatic cycle-counter.

We recommend that aluminium vessels should be exchanged after 15 years at the latest.

Please pay attention to and follow these measures, for your own safety and that of you employees and customers!

In order not to unnecessarily load the pressure vessels additionally, the non-return valves, that are meant to avoid a drop in pressure, and also the pressure maintaining valves, which should reduce big pressure fluctuations as well, should be checked regularly for internal and external tightness and functionality.

- Check the pressure vessels regularly on the inside and outside for damage from corrosion.
- Be particularly careful with second-hand pressure vessels, when their previous operating mode is not specifically clarified.

2.4. SAFETY REGULATIONS (EC; partly Germany, only)

A compressor is identified by German law as being a filling system if pressure cylinders are filled by the system, especially when these cylinders are made available for third parties. The start-up and operation of compressor systems for use as filling stations is governed by the following regulations:

Pressure vessel directive (Directive 97/23/EC) of 29.05.1997

Operating safety regulations (BetrSichV) of 27.09.2002
Machine safety law (GSG) of 11.05.2001

14th regulation to machine safety law (14. GSGV - pressure vessel regulation) of 03.10.2002

If a high pressure compressor is used for filling pressure vessels or for the supply of pneumatic systems, the following regulations apply:

Accident Prevention Regulations (UVV):
BGV A1 of 01. January 2004

Copies of the above regulations are available through the usual outlets, e.g. in Germany from:

Carl Heymanns Verlag
Luxemburger Str. 449
50939 Köln

Beuth-Vertrieb GmbH
Burggrafenstr. 4 - 7
10787 Berlin

The manufacturer has complied with all applicable regulations and the unit is prepared accordingly. If desired, we offer at our Munich site a partial acceptance test according to §

14 BetrSichV. Please contact our Technical Service Department with regard to this. They can also supply our leaflet **"IMPORTANT NOTES FOR CERTIFICATION"**.

According to the operation safety regulations (BetrSichV), all compressor units which will be used as filling stations must undergo an acceptance test by a professional at their location before bringing them into service. If pressure vessels (bottles) are to be filled by the compressor for a third party then the appropriate permission must be obtained from the responsible authority before the acceptance test. As a rule, this is the factory inspectorate. The procedure for obtaining permission is according to TRG 730, guidelines for permission to set up and operate filling stations. The test certificates and documents delivered with the compressor are important and may be requested during the procedure for obtaining permission. In addition, the documents belonging to the unit are important for recurrent inspections and should therefore be carefully kept.

Inspections in accordance with the regulations for prevention of accidents will be carried out by the manufacturer or by a specialist.

No guarantees whatsoever are valid for damage caused or favoured by the non-consideration of these directions for use.

We strongly emphasize these regulations.

3. LOCATION, OPERATION, BOTTLE FILLING

LOCATION

WARNING Never operate the compressor in potentially explosive atmosphere!

WARNING Keep unit away (min. 2m) from inflammable items. Do not smoke while petrol tank is open and while unit is in operation.

Outdoor location



The compressor unit is not seawater resistant. At operation in salty air spray compressor with anticorrosive protection (e. g. Quicksilver Corrosion Guard). Electric driven units should be operated and stored below deck. Units with petrol engine should also be stored below deck after the filling process.

- Locate the unit level.
- On units with petrol engine it is most important that only clean air be used, position compressor in direction of wind so that exhaust fumes are blown away from the unit. Please use the provided telescopic intake tube. See Fig. 7 and chapter 4.4.2. This arrangement will ensure necessary spacing between exhaust outlet and air inlet.

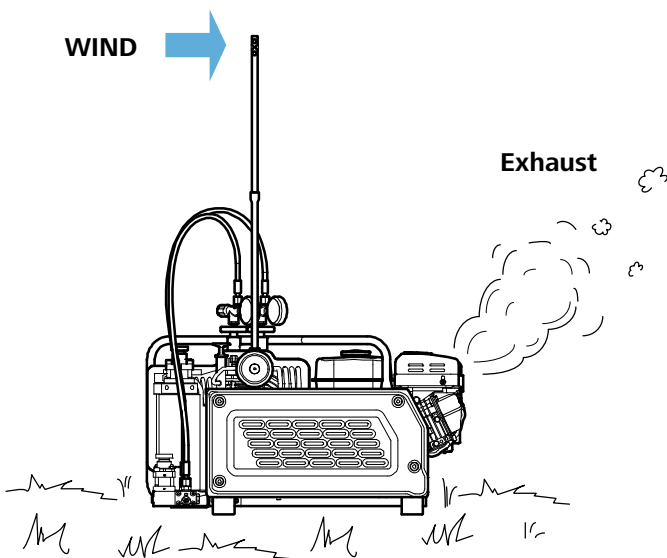

Fig. 7 Outdoor location

- Turn unit as soon as wind direction changes.
- Take care that no vehicles are in direct vicinity with engines running.
- Do not operate unit in the vicinity of open fire (flue gas!).

Indoor location

WARNING Petrol driven units must not be operated indoors.

- Ensure adequate ventilation.
- Here too, air must be free from exhaust fumes and hazardous vapours (e.g. smoke, solvent vapours, etc.).
- If possible install unit in such a manner that the compressor fan can get fresh air from outside, for instance through an opening in the wall.
- Ensure that an adequate exhaust air opening is provided.
- When locating the compressor in small rooms where natural ventilation is not ensured, measures must be taken to provide artificial ventilation (this also applies when other systems having high radiation are operating in the same room).

Electrical installation

For installation of electrical equipment observe the following:

- Comply with regulations of local electricity supply company.
- Arrange for the electrics to be connected by an electrician only.
- Ensure correct installation of protective conductor.
- Check conformity of motor tension and frequency with those of electric network.
- Operate electric units only on mains sockets equipped with fault current circuit breaker according to DIN VDE 0664 with a nominal differential current of less than 30 mA (up to 16 A in single-phase AC circuits).
- For units not connected through a plug, but permanently installed, a main switch must be provided which has a contact gap of minimum 3 mm on each pole.
- Fuse motor correctly; use slow-blow fuses, only.
- Immediately after start-up check direction of rotation for agreement with arrow on unit.



If power supply cable is to be replaced, use cable of same type, only!

- When using extension leads or cable drums, operate unit with unwound cable, only to avoid overheating and risk of fire. The maximum length for extension cables at normal ambient temperatures (approx. 20 °C) is 25 metres.

WARNING The power plug must be easily accessible and separable to shut down quickly the unit in case of emergency.

OPERATION

Preparation for operation



All compressor units are tested prior to delivery to the customer, so after correct installation of the unit there should be no problem putting it into operation, observing the following points:



The compressors described in this manual are not suitable for compression of oxygen. EXPLOSION occurs if an oil lubricated compressor is operated with pure oxygen or gases with an oxygen content of more than 21%!



Due care must be taken to ensure that any oil which may be drained with the condensate will not pollute the environment. For example, the drain pipe can be directed into a collecting vessel or into drain facilities incorporating oil separators. Dispose of condensate according to local regulations!

- Prior to first operation read Instruction Manual carefully. Make sure that all persons handling the compressor and the filling station are familiar with the function of all controls and monitors. Particularly observe chapter 2 **SAFETY REGULATIONS**.
- After taking unit into operation after a standstill period of 2 years or more change compressor oil. When using a mineral oil change oil after one year.
- Prior to **first** operation or operation subsequent to repair work operate unit for at least 5 minutes with open condensate valves (pressureless) to ensure proper lubrication of all parts before pressure is built up.
- Prior to **each** operation check the oil level according to chapter 4.4.1. and determine whether maintenance is necessary in accordance with chapter 4.3.
- Every time the unit is started up check all systems for proper operation. If any malfunction is observed stop unit immediately and find the cause of the fault or call the service department.

Units with three phase current motor, additionally:

- Immediately after switching on the system for the first time check the direction of rotation of the motor for compliance with the arrow on the unit. If motor turns in the wrong direction, the phases are not connected properly. Shut down unit immediately and interchange two of the three phase leads in the switch box. Never change leads at the motor terminal board.
- Units with compressor controller monitor automatically the direction of rotation of the motor. In case of wrong direction the red warning lamp E1 (1, Fig. 9) lights up and the power supply for the motor is cut off. Disconnect the unit from the power supply and interchange two of the

three phase leads in the plug. Never change leads at the motor terminal board or at control box.

Units with petrol engine, additionally:

- Check engine oil level according to manufacturer's instruction manual.
- Check fuel tank. Top up if necessary.

Starting the unit

- Open condensate drain taps on the filters to release pressure so that motor starts without load. On units with automatic condensate drain the compressor is depressurized automatically.

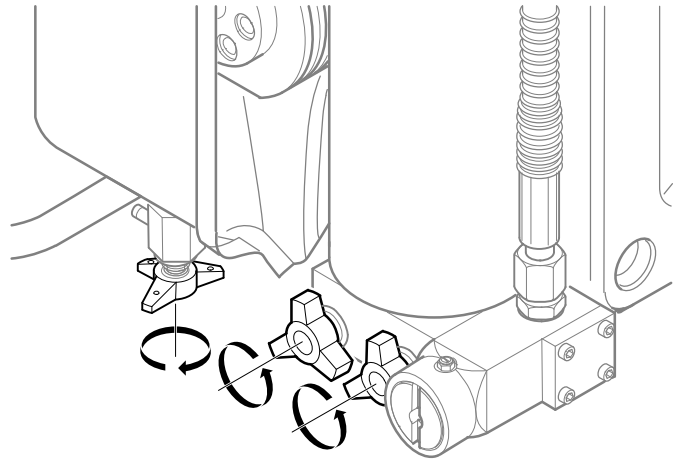

Fig. 8 Opening the condensate drain taps

Units with electric drive motor:

- **Three-phase current:** the motor is switched on manually by setting the switch (Fig. 9) to 1.
- **Alternating current:** Set 0-I switch to I.

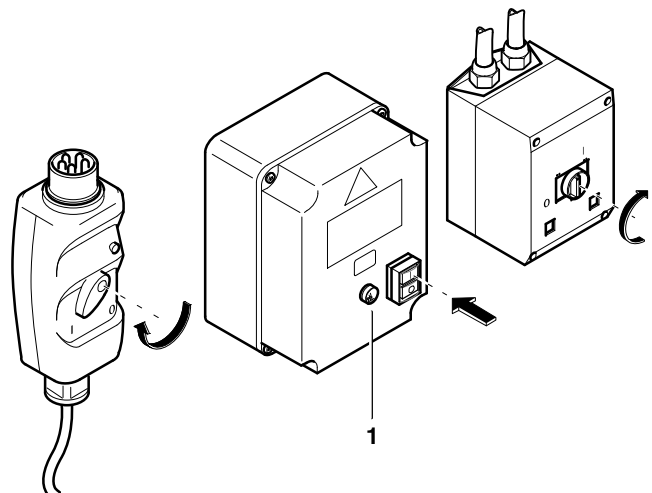

Fig. 9 Starting electric units

Units with petrol engine:

- Open fuel shut-off valve (1, Fig. 10).
- Set ignition switch to I (2)
- Set choke to position START (3). Start engine with rope starter (4). As soon as motor runs smoothly return choke to normal operating position.

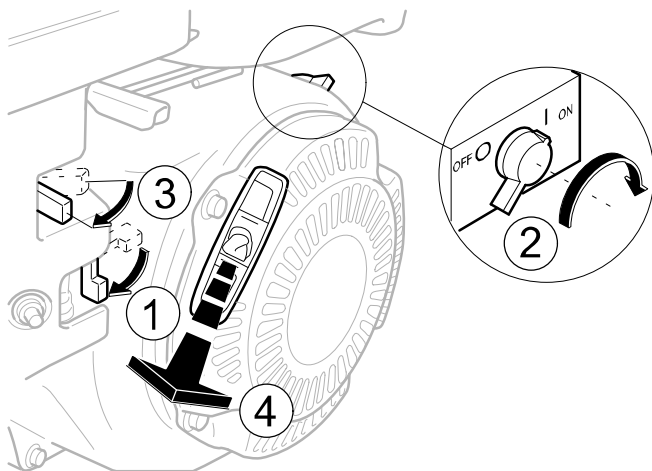

Fig. 10 Starting petrol units

All units

- Close condensate drain valves and run unit to final pressure. Check final pressure safety valve and pressure gauge.
- As soon as final pressure is reached and final pressure safety valve blows off, open condensate drain taps and drain condensate - unit is ready for filling operation. Observe regular condensate drain acc. to chapter "Maintenance".

FILLING PROCEDURE

General

WARNING Ensure intake air is free from noxious gas (CO), exhaust fumes and solvent vapour. On units employing petrol or diesel engine it is most important to use an intake hose and observe that only clean air is drawn in. The intake hose is also recommended for units with electric engine. When operating the unit in areas with possibly high CO contents, the CO removal filter cartridge is recommended for electric driven units, also. Note that for CO contents of more than 25 ppmV in the intake air the allowed limits cannot be guaranteed even with a CO removal filter cartridge, resulting in a life-threatening CO concentration! Also, due to chemical reaction of CO with hopcalite, warming up of the cartridge and danger of fire may result.

WARNING Filling hoses must be in satisfactory condition and threads undamaged. Pay particular attention to damage on the interface from hose fitting to hose. If the casing is scored, hose must be discarded.

WARNING Never open unconnected filling valves while they are under pressure. Risk of accident from escaping high pressurised air!

The filling valve connection is of the manual type and permits connection to air tanks without using tools. An O-ring is provided for self-sealing due to internal overpressure. Compressed air tank filling valves for a pressure in excess of 200 bar are standardized (DIN 477, sheet 5) and connectors for 200 and 300 bar are different and cannot be mixed up. **The use of adapters is not allowed!**

To ensure safe air tank removal after filling, the valve has an integral venting bore. Therefore always close tank valve first before closing filling valve. During filling procedure bottles will warm up due to recompression. After removing, allow to cool down, bottles may then be reconnected and topped up to the respective maximum filling pressure.

WARNING To meet the CO₂ maximum rating value in breathing air bottles, please observe the two following chapters "Intake air quality" and "Scavenging the compressor unit".

Intake air quality

At routine tests, CO₂ values beyond the permissible values are noted from time to time. Closer investigations often show that the compressed air is taken from rooms in which one or more persons are working. At insufficient ventilation, the CO₂ value in the surrounding air can increase quite fast because of the exhaling of CO₂. CO₂ values from 1,000 to 5,000 ppmv in workrooms are not unusual (MAK-value (max. workroom concentration) is 5,000 ppmv). Another additional increase is caused by cigarette smoking, producing approx. 2g CO₂ (≈ 2,000 ppmv) per cigarette. These pollutions add up to the basic pollution of approx. 400 ppmv. The technically caused excessive increase of CO₂ during the filling process and the CO₂ peak at taking the unit into operation. **Because of the reasons stated above and for your own security, the filling of breathing air bottles is not allowed in rooms used as workrooms.**

Scavenging the compressor unit

CO₂ is present in the atmosphere with a natural amount of 350 to 400 ppmv. The molecular sieve used in the purifier for drying the breathing air is, as well as other capabilities, able to adsorb CO₂ which is accumulated in the cartridge. After shut-down of the compressor, adsorbed CO₂ may be desorbed again due to the partial pressure decrease. The now free CO₂ then gets washed out of the cartridge when the compressor is started again. To avoid increased CO₂ contents in the compressed breathing air, we recommend to flush the compressor unit 1 to 2 minutes prior to connecting the bottles, i.e. to let the air escape into the surroundings through the filling valve.

Connecting the bottles



neck).

On models of 300 bar rated filling pressure do not attach bottles unless rated for this pressure (note pressure stamped on tank

- Connect air bottle to filling valve (see Fig. 11).
- Air bottles with international filling connector can be connected with filling adaptor (part no. 79375) to the German filling connector (see Fig. 12).



The international connector is not permitted in the Federal Republic of Germany. In other countries it is allowed only for pressures up to 200 bar (2,850 psi).

Filling the bottles

- Open filling valve (1, Fig. 13).
- Open bottle valve (2) - bottle will be filled. Drain condensate regularly during filling. On units with automatic condensate drain check that condensate is drained regularly.



The filling procedure should not be interrupted for more than 10 minutes to avoid increased CO₂-values in the air filled into the bottles.

Removing the bottles

- Upon reaching final bottle pressure **close bottle valve first** (1, Fig. 14), **then filling valve** by returning handle to closed position (2).
- Remove compressed air bottle.

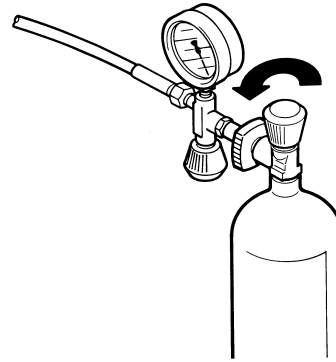

Fig. 11 Connecting air bottle

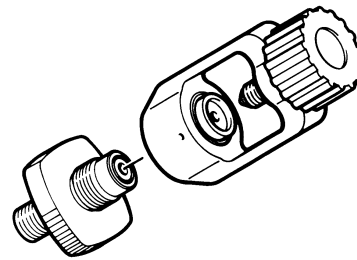

Fig. 12 International filling connector

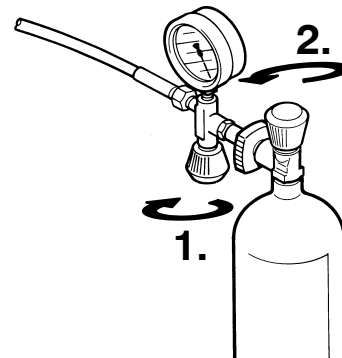

Fig. 13 Filling air bottle

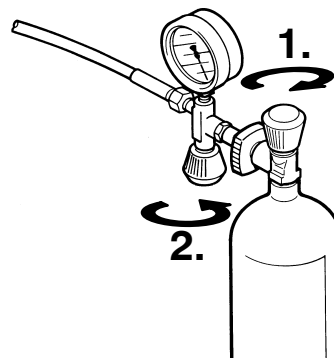

Fig. 14 Removing air bottle

CHANGE-OVER DEVICE PN 300/PN 200

(Fig. 15) This device allows bottle filling to 200 bar (3,200 psig) with a 300 bar (4,700 psig) rated unit. Safety valve -B and filling device PN 200 bar are connected by opening change-over valve -A and the connected bottles can be filled with a 200 bar pressure, as described in "Filling the bottles".



Depressurize unit before opening valve -A to avoid damage to the change-over device

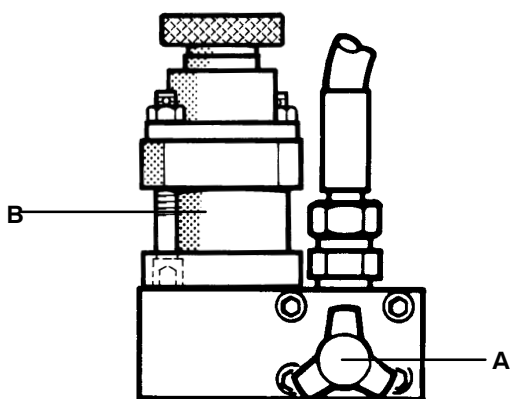

Fig. 15 Change-over device

SHUT-DOWN PROCEDURE

- Close filling valve.

Units with electric motor:

- **Three-phase current:** the motor is switched off by turning the switch to 0.
- **Alternating current:** set 0 - I switch to 0.

Units with petrol engine:

- Shut down petrol engine by turning the ignition switch to "0".

All units:

- Drain condensate from intermediate separator and Triplex filter by means of the drain taps. Vent unit by means of filling valve to approx. 80 bar (1,150 psi). Close all valves again to prevent moisture entering the filter and resulting saturation of the cartridge.
- Check the oil level in the compressor and top up, if necessary. Also check whether the compressor needs servicing in accordance with maintenance schedule - see chapter 4.3.

B-TIMER (option)

Introduction

Read these operating instructions carefully before using the B-TIMER. (Valid for devices from version 300.301.811 onwards).



The settings in the setup menu are critically important in terms of the ability to display the filter capacity correctly. Without these settings, the B-TIMER can only be used as an operating hours counter!



Ensure that the compressor's pressure retention valve is set to 160 bar (factory setting, refer to chapter 4.4.5.) and that it is functioning correctly, otherwise the filter capacity may be displayed incorrectly and the operation may not, under certain circumstances, be detected correctly.



Before delivery, ensure that all the maintenance counters (a+b+c) have been reset. (Otherwise, the B-TIMER signals incorrect maintenance intervals, since the storage times are not taken into consideration.) If the items in question have not been reset, it must be done without delay. Refer to the 'Reset' chapter.

DESCRIPTION

The **B-TIMER** (Fig. 16) is a self-activating mini-computer that keeps track of the compressor's operating hours and calculates the filter cartridges' lifetime with the help of the time, the temperature, the type of cartridge and the delivery quantity of the compressor. It displays the operating hours, the cartridge's service life and the compressor's upcoming maintenance-related tasks. The **B-TIMER** needs neither an external power supply nor a connection to the compressed air system. It is mounted on the enclosure of the filter to be monitored with the help of a fastener and is thus the ideal monitoring device for all mobile compressors. It is particularly well-suited for sport-diving devices that are powered by either gasoline or diesel fuel. Any system can easily be retrofitted with the B-TIMER.

Intended usage

This device serves solely as an appliance that can be used to display the operational status and does not release the user from the additional responsibility to monitor and measure the breathing air quality of the filter system in accordance with national norms (e.g. EN 12021). This **cannot** be done with the **B-TIMER**.

The **B-TIMER** may only be used with **BAUER** compressors, **BAUER** processing plants and original **BAUER** filter cartridges. It has only been designed and approved for the following **BAUER** filter systems: P21, P31 and P41. The respective cartridge numbers are contained in the software. Every other type of utilisation counts as utilisation that is not in accordance with the regulations. Damages resulting from such utilisation are subject to the manufacturer's/supplier's risk exclusion, warranty exclusion and liability exclusion policies.

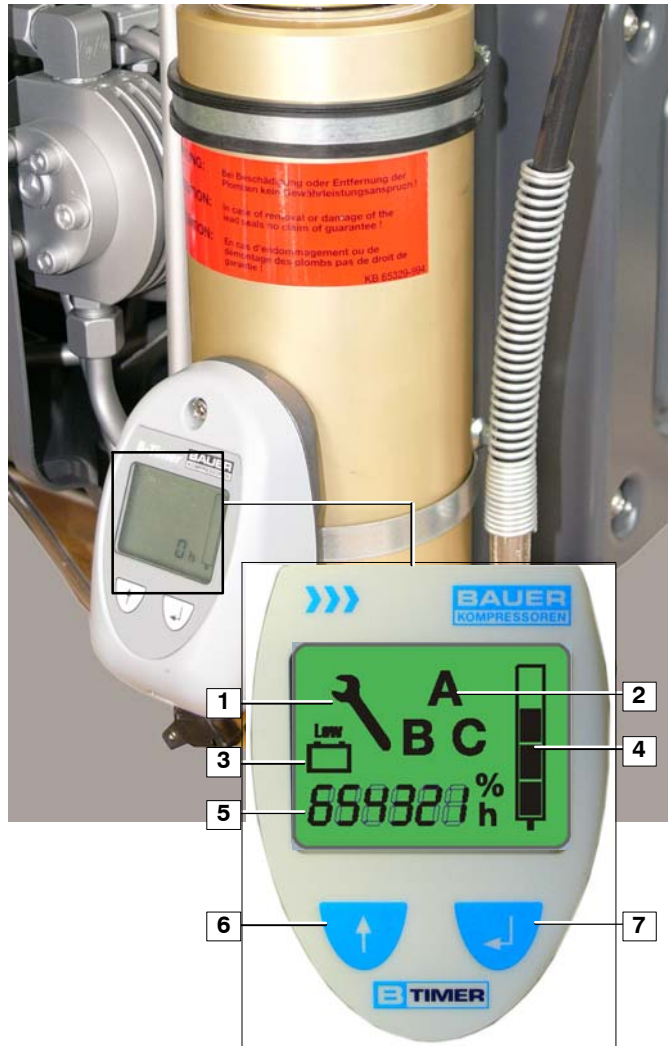

Fig. 16 B-Timer

- 1 Key symbol (maintenance due)
- 2 Alphabet (type of maintenance)
- 3 Battery symbol
- 4 Cartridge saturation display
- 5 Operating hours or cartridge no.
- 6 Selection keys
- 7 Entry keys

Be mindful of the **application limits** of the device:

Working temperature: 0 °C to +50 °C

Storage temperature: -20 °C to +70 °C

Protection class: IP65 (protection against contact, dust-proof, Protection against hose water)

Vibration, ± 3 g when in operation,

Max. humidity: 95%; non-condensing

Method of functioning

The **B-TIMER** display displays the following functions:

- Operating hours of the compressor plant. A blinking 'h' indicates that the compressor-operation has been detected (subject to a 5-minute delay).
- Cartridge life in % via 4 segments in the filter-cartridge symbol.
- When the remaining capacity reaches or falls below 20% of the total lifetime, the final segment starts blinking and the figure displayed for the operating hours switches over to the cartridge's order number.
- The compressor plant displays the upcoming maintenance-related tasks with the help of alphabets and figures displaying the operating hours.
A = 500 hours or 1 year
B = 1000 hours or 2 years
C = 2000 hours or 4 years
- A battery symbol is used to indicate that the lithium battery is weak and must be replaced. **The data is saved and is not lost when the battery is changed.**

The **B-TIMER** is operated with the help of the entry and selection keys.

Error display

If the temperature sensor in the device malfunctions, 'Error 1' or 'Error 2' comes up at the display (Fig. 17). In such a case, use of the B-TIMER should be discontinued. Send the device to the factory for repairs, or send it to the next agency.

Battery replacement

The battery (1, Fig. 18) is placed in the battery compartment. To replace the battery, withdraw plug (2) and pull the battery out of the battery compartment. Make sure you use a battery of the same type (BAUER order number 82743).

Operation



The B-TIMER switches itself on when the compressor is activated. The fact that the compressor is in operation is indicated by the blinking 'h' symbol.

To switch on the B-TIMER without putting the compressor into operation, press one of the buttons on the display: the main menu is displayed (Fig. 19).



If no button is actuated for 1 minute, the display reverts to the main menu. The B-TIMER switches itself off if the compressor-operation is not detected in 2 minutes.

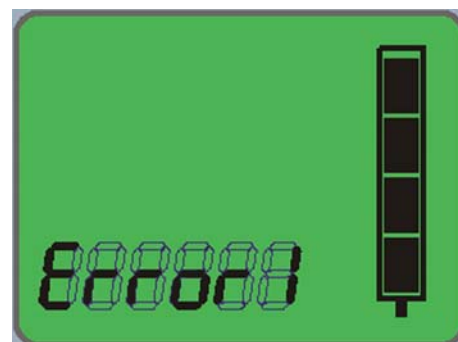

Fig. 17



Fig. 18 Battery

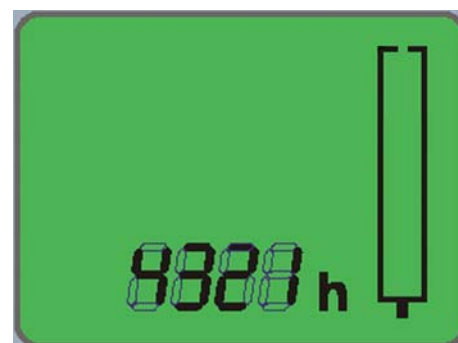

Fig. 19

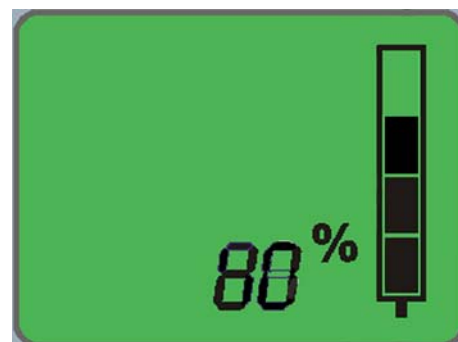

Fig. 20

Functional display



Press the selection button to display the desired function (↑).

Press the ↑ button. The remaining filter capacity is displayed (Fig. 20).

Press the ↑ button. The number of operating hours lying between the point in question and service interval A (500 hours or yearly) is displayed (Fig. 21).

Press the ↑ button. The number of hours remaining before service interval B (1000 hours or every two years) is displayed (Fig. 22).

Press the ↑ button. The number of hours remaining before service interval C (2000 hours or every four years) is displayed (Fig. 23).

Press the ↑ button. The filter-cartridge number is displayed (Fig. 24). The filter icon blinks.

Press the ↑ button. The display reverts to the main menu.

Reset



The filter capacity may only be reset after the cartridge has been replaced!

To reset the filter capacity or the A, B and C service intervals, hold the ↓ button down for more than 5 seconds when the respective display has been activated (Fig. 25).

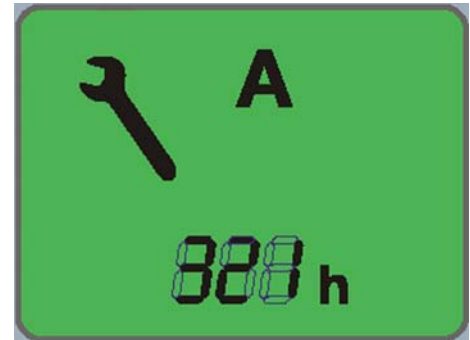

Fig. 21

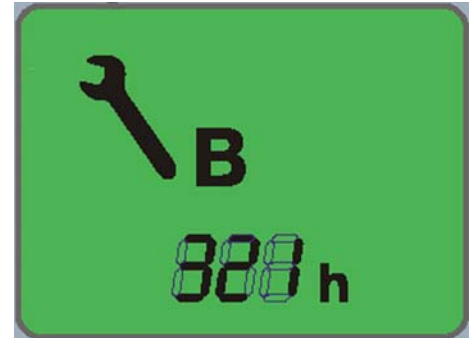

Fig. 22

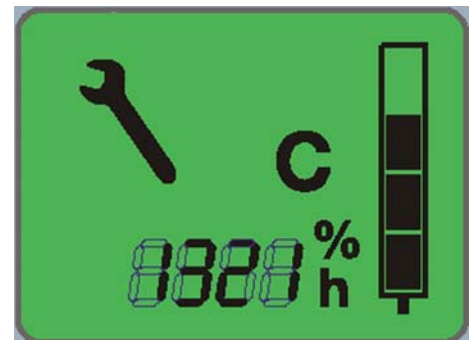

Fig. 23



Fig. 24



Fig. 25

Setup

To navigate to the setup menu of the various functions of the **B-TIMER**, hold down the ↑ and ↓ buttons simultaneously for more than 5 seconds when the cartridge number is being displayed (Fig. 24). The filter icon starts blinking (Fig. 26), which indicates the setup mode.

The applicable filter cartridge no. is set under **setup A**. To change the article number, hold down the ↓ button for 3 seconds, after which the number starts blinking. Use the ↑ button to set the desired number. Use the ↓ button to accept the number in question.



Article numbers beginning with 999 must be set in a special manner.

Hold down the ↓ button for 3 seconds, and then enter 999000 with ↑. The last 0 starts blinking. Appoint the corresponding digit with ↑ and accept it with ↓. When the 2nd zero starts blinking, appoint the digit as described above, and carry out the same procedure for the 3rd digit.

When the ↑ button is pressed, the display switches over to **setup B** (setting of the delivery quantity). The filter icon starts blinking (Fig. 27). The delivery quantity (in l/min.) can be found in the compressor's instruction manual. To change the configuration, hold down the ↓ button for 3 seconds, after which the 1st digit starts blinking. Use the ↑ button to set the desired number. Use the ↓ button to accept the number in question and repeat the same procedure until all three digits have been set correctly.

When the ↑ button is pressed again, the display switches over to **setup C** (setting of operating pressure). The filter icon starts blinking (Fig. 28).

To change the operating pressure, hold down the ↓ button for more than 3 seconds. Press the ↑ button to enter the new operating pressure. (Options: 200 bar, 300 bar or 200/300 bar). Press the ↓ button to confirm the new setup.



The filter capacity must be reset after the setup preferences have been entered and a new filter cartridge has been inserted. Refer to the 'Reset' section.

When the ↑ button is pressed again, the display switches over to the **setup menu for the operating hours**. Press the ↓ button for 2 seconds, after which the last digit starts blinking. Use the ↑ button to appoint the desired digit and press the ↓ button. Repeat this procedure until all the digits have been entered. Repeated actuation of the ↑ button leads the system back to the main menu. Pressing the ↑ and ↓ buttons (for 2 seconds) makes it possible to repeat the setup procedure.

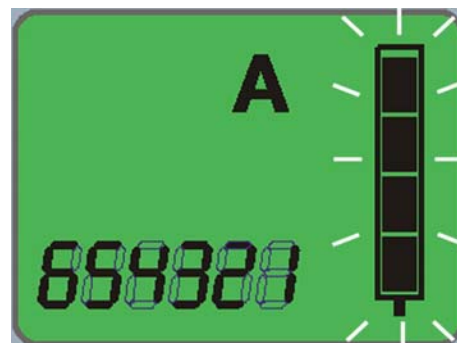

Fig. 26

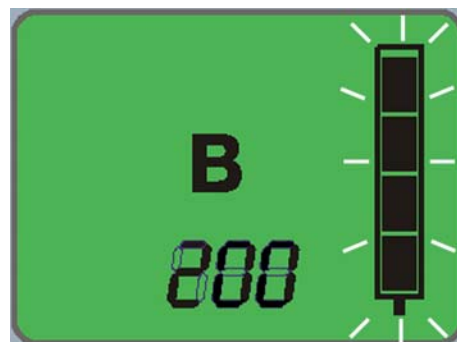

Fig. 27

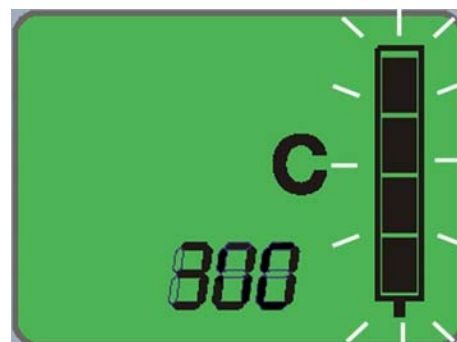

Fig. 28

4. MAINTENANCE

4.1. MAINTENANCE RECORD

We recommend that all maintenance work is recorded in the service book, showing the date and details of the work carried out. This will help to avoid expensive repairwork caused by missed maintenance work. If it is necessary to claim against the warranty, it will help to have proof that regular maintenance work has been carried out and that the damage has not been caused by insufficient maintenance. Please refer to section 23 of our general terms and conditions.

4.2. MAINTENANCE INSTRUCTIONS

WARNING Always shut down and decompress the complete system prior to carrying out any work on the compressor.

WARNING Never repair pressure lines by soldering or welding.

WARNING Replace and check for function all protection and safety equipment after maintenance or repair work.

WARNING Check weekly fixation and condition of all protection equipment. Retight or replace fastening screws if necessary.

 Check the complete system for leakage from time to time by brushing all fittings and couplings with soapy water or spraying with leak test spray. Repair any leakage.

 Only use original spare parts for maintenance or repair work.

 Change TRIPLEX longlife cartridge according to chapter 4.4.4.!

 The used cartridge must be disposed of according to local regulations.

 Maintenance of drive motor/engine according to manufacturer's operating instructions.

4.3. MAINTENANCE SCHEDULE

The maintenance schedule is contained in the service manual delivered with every compressor unit.

4.4. MAINTENANCE WORK

This chapter contains the maintenance work as well as a short functional description for each component.

4.4.1. LUBRICATION

TYPE OF OIL

For proper care and maintenance of the compressor, using the correct oil is of vital importance. Depending on the application of the compressor the requirements placed on the oil are:

- low deposits
- no carbonizing effect, especially in the valves
- good anti-corrosive properties
- emulsification of the condensate in the crankcase
- physiological and toxicological suitability.

Due to the thermal load on the compressor only high quality oil should be used. You are recommended to restrict oils to those which have been approved by us and are listed in our lubricating oil list.



The current oil list is provided in the annex, chapter 8. Order this list regularly through the BAUER Technical Service Department.

For operation under difficult conditions such as continuous running and/or high ambient temperatures we recommend the use of **BAUER** high performance compressor oils, only, according to the oil list. These oils are tested in our compressors and have proved excellent quality under ambient temperatures between +5 °C (41 °F) and +45 °C (113 °F). For lower temperatures, a heating device is required which is capable of pre-heating the crankcase up to +5 °C (41 °F).

For operation under less severe conditions, for intermittent operation, or operation with long idle periods we can also recommend mineral compressor oils which are suitable for operation under ambient temperatures between +5 °C (41 °F) and +35 °C (95 °F). Here also, pre-heating is required for lower temperatures.

OIL LEVEL CHECK

Check oil level daily prior to putting compressor into operation. Check using oil dipstick.

Take care that dip stick is inserted completely. Note that the oil level must be between minimum and maximum dipstick markings (see Fig. 29).



Oil level must not decrease below min. mark but also not exceed max. mark as this will cause excessive lubrication of compressor and result in valves sooting up.

OIL CHANGE INTERVALS

Mineral oils	every 1,000 operating hours, at least annually
Synthetic oils	every 2,000 operating hours, at least biennially

OIL CAPACITY

Junior II	approx. 360 ml
-----------	----------------

OIL PACKAGES

BAUER compressor oil is available in various quantities, refer to oil list in chapter 8.

OIL CHANGE

- Run compressor warm.
- Remove oil dipstick.
- Drain oil while still warm by means of oil drain plug. Replace the sealing, reinstall drain plug and tighten well.
- Refill with oil through the oil filler neck.
- Oil level is checked with oil dipstick, oil level is correct if at upper mark.

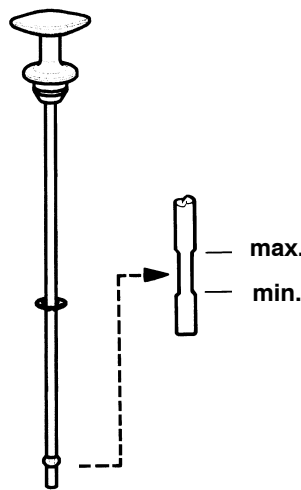

Fig. 29 Oil dipstick markings

CHANGING THE OIL TYPE



To avoid severe damage to the compressor unit when changing the oil type, the following measures should be strictly adhered to:

- Drain oil completely while still warm.
- Check valves, coolers, separators, purifiers, and all pneumatic tubes and hoses for deposits.

If deposits are detected, perform the following:

- Change or clean valves, coolers, separators, purifiers, and all pneumatic tubes and hoses from deposits.
- Fill compressor with the new oil.
- After approx. 100 operating hours check lubricating oil for degree of contamination, and change oil again if necessary.
- Top up compressor and perform subsequent oil changes with same oil, only.

4.4.2. INTAKE FILTER

DESCRIPTION

A dry micronic filter is used to filter intake air (Fig. 30).

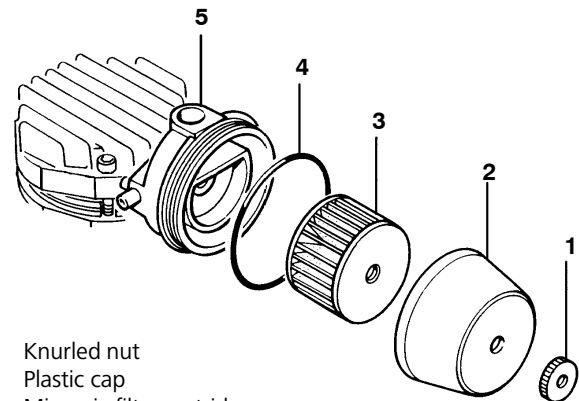

- 1 Knurled nut
- 2 Plastic cap
- 3 Micronic filter cartridge
- 4 O-ring
- 5 Opening

Fig. 30 Intake filter

INTAKE FILTER MAINTENANCE

Filter cartridge must be changed at regular intervals according to schedule in the service booklet.

- Remove knurled nut (1) and take off plastic cap (2). Remove filter cartridge (3).
- Clean filter housing inside with a damp cloth. Take care to prevent dust from entering intake pipe.
- Replace O-ring (4) if damaged.
- Insert a new filter element and fasten with cap and nut.

TELESCOPIC INTAKE TUBE

The telescopic intake tube has to be inserted in opening 5, Fig. 30. It is necessary to ensure clean air. Petrol driven breathing air compressor units are fitted with a telescopic intake tube supplied with the unit. The use of it is also recommended for electric power driven units.

4.4.3. INTERMEDIATE SEPARATOR

DESCRIPTION

An intermediate separator is mounted on the compressor between 2nd and 3rd stage. It is designed to remove water and oil accumulating due to cooling the compressed medium down after the compression process.

Separation is achieved by means of centrifugal action provided by a vortex plate.

INTERMEDIATE SEPARATOR MAINTENANCE

Proper operation will rely on the intermediate separator being properly serviced.

Open drain tap (1, Fig. 31) and drain off condensate every 15 to 30 minutes during operation.



Fig. 31 Condensate drain taps

4.4.4. FILTER SYSTEM P21

DESCRIPTION

The air leaving the final stage is cooled in the after-cooler to approx. 10 - 15 °C (18 - 27 °F) above ambient temperature and then enters filter system **P21** with **TRIPLEX** longlife cartridge (Fig. 32).

The filter assembly consists of separator and cartridge chamber. In the separator surrounding the cartridge chamber liquid oil and water particles are reliably separated from the compressed medium by a pipe nozzle.

Residual oil and water vapors are then removed by the **TRIPLEX** longlife cartridge. The quality of the breathing air produced conforms to DIN EN 12021.

CARTRIDGE SAFETY BORE

The filter system **P21** is designed to prevent pressurizing in the absence of the filter cartridge. A bore provided in the filter bottom is sealed air-tight only if the cartridge is in place (Fig. 33).



No pressure build-up without cartridge!

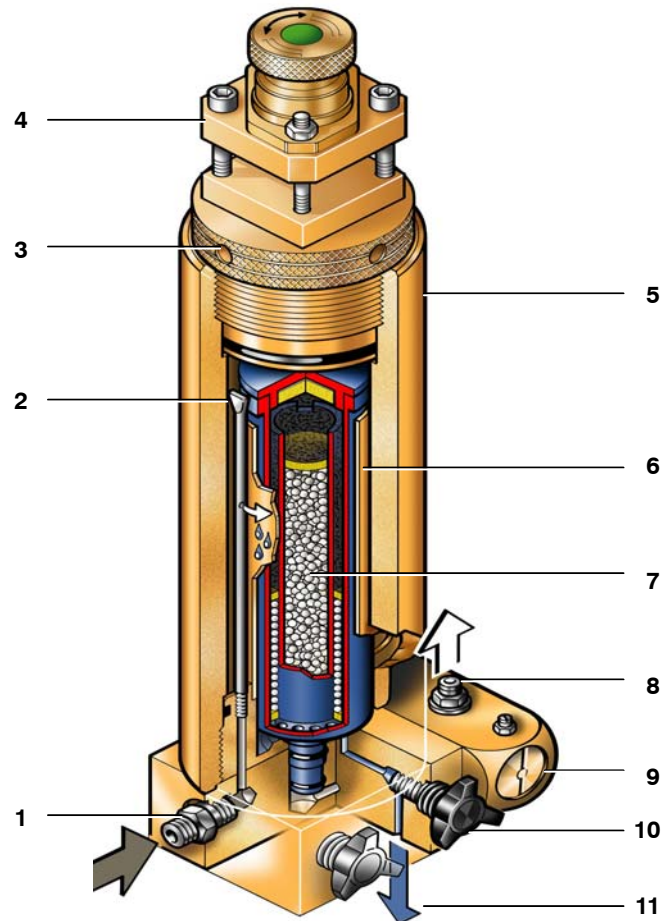

Fig. 32 Filter system P21

- 1 Filter inlet
- 2 Jet pipe
- 3 Filter head
- 4 Final pressure safety valve
- 5 Housing
- 6 Chamber separator
- 7 Cartridge
- 8 Filter outlet
- 9 Pressure maintaining valve
- 10 Condensate drain tap
- 11 Condensate outlet

Without cartridge the venting bore is not sealed, the air escapes into the atmosphere, no pressure can be built up and thus it is ensured, that unfiltered air is not supplied to the consuming device.

The venting bore is also used to check the O-rings on the cartridge pin. If air is leaking out of the venting bore even though a cartridge is installed, the O-rings are either broken or were damaged on installation.

Remove and check cartridge. If necessary replace cartridge or O-rings.

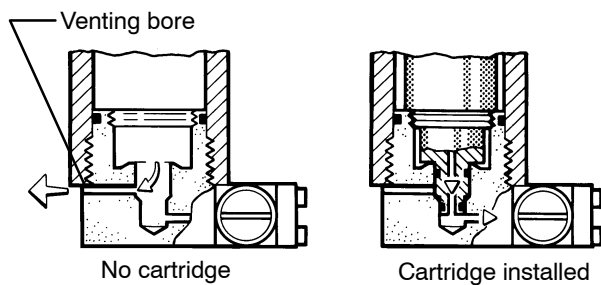

Fig. 33 Safety bore

LIFETIME

WARNING

The filter system is subject to dynamic load. It is designed for a certain number of load cycles, which originate from an abrupt pressure loss at condensate drain (1 load cycle i.e. condensate drain = 1 depressurization, 1 pressurization). The filter housing has to be inspected internally by an expert after having reached 1/4 of the determined number of load cycles. The inspections have to be arranged by the operator. After reaching the max. number of load cycles the filter assembly must be replaced, otherwise the housing may burst due to material fatigue.

The max. number of load cycles for the P21 Central Filter Assembly is **4,000** if operated at the max. allowable pressure difference range of 330 bar (4,700 psi). For a pressure difference of 225 bar (3,200 psi) the max. no. of load cycles is **35,000**.

To avoid exceeding the max. number of load cycles the operating hours should be recorded in the service manual. On condition that a max. number of four cycles per hour is not exceeded (condensate is drained every 15 minutes) the max. number of operating hours is **1,000 for 330 bar units**, and **8,750 for 225 bar units**.

GENERAL INSTRUCTIONS FOR FILTER MAINTENANCE

- **Depressurize** system before starting any maintenance work.
- **Dry** inside of filter housing with a clean cloth before installing new cartridge and check for corrosion. Change if necessary.
- **Lubricate** threads and O-rings as well as threaded part of cartridge with white petrolatum DAB 9 order no. N19091 or WEICON WP 300 white order no. N19752.
- **Record** number of pressure bottles and/or operating hours to ensure exact attention to maintenance intervals.
- **Change** cartridge before reactivating a compressor unit after out-of-service periods of more than 3 months.
- **Leave** cartridge in the filter as long as unit is out of service.
- **Keep** all condensate drain valves and taps closed. Keep a minimum pressure of approx. 50 to 80 bar (700 to 1,100 psi) within the system to prevent moisture entering the compressor piping and filter system.

- The nozzle type separator of the **TRIPLEX** filter system is maintenance-free besides the regular condensate drainage.

CONDENSATE DRAINAGE

Drain condensate from separator and cartridge chamber regularly by slowly opening drain taps (2 and 3, Fig. 31)

- before changing cartridge
- before each filling procedure
- during filling procedure every **15 minutes**.

Slowly open left tap first, then right tap approx. 1/3 turn to the left, until condensate is completely drained. The taps close by spring pressure, if necessary tighten by hand to make sure they are completely air-tight.

FILTER CARTRIDGES

New filter cartridges are vacuum-packed and can be stored for two years (refer to date on the cartridge). A defective vacuum package cannot protect the cartridge appropriately against environmental influences during storage. Should the package be damaged, do not use the cartridge.

To avoid any danger to your health or damage to your unit, change used up cartridges in good time.

Never fill used up cartridges yourself! The filter material was chosen specifically by BAUER-KOMPRESSOREN for each kind of application.

Pay attention to cleanliness and hygiene when changing the filter.

FILTER SERVICE LIFETIME

The average weight (without package) of a new cartridge and the increase in weight can be checked with appropriate weighing scales. Due to inevitable production tolerances, there may be small differences compared to the given data.

The number of operating hours or the amount of possible bottle fillings per filter cartridge can be determined by the tables on page 25 and 26 taking into consideration the ambient temperature and the cartridge used.

These tables contain calculated cartridge lifetime data, that refer to defined and constant operating conditions. Tolerances at bottle fillings and different operating temperatures can lead to considerable divergences compared to data given, which therefore can only serve as reference values for the user.

Cartridge 057679 is the normal TRIPLEX-cartridge for electric units.

Filling weight: 191 g; Saturation weight 205 g.

Example: at an ambient temperature of 20°C, 36 to 45 10-ltr-bottles can be filled with a TRIPLEX-cartridge, which is equivalent to 12 to 15 compressor operating hours at a filling pressure of 200 bar.

On compressor units with petrol engines only use **cartridge, part no. 059183 to dry, de-oil and remove CO.**

Filling weight: 217 g; Saturation weight 229 g.

Example: at an ambient temperature of 20°C, 31 to 38 10-ltr-bottles can be filled with this cartridge, which is equivalent to 10 to 12 compressor operating hours at a filling pressure of 200 bar.

alent to between 10 and 13 operating hours at a filling pressure of 200 bar.



The longer service life of the cartridge at a filling pressure of 300 bar is annihilated by the larger volume of filled air per bottle, therefore the possible number of bottle fillings stays the same at different pressures.

CARTRIDGE CHANGE

WARNING

For safety reasons only CO removal cartridges part no. 059183 should be used on compressor units with petrol engine. On units with electric engine either CO removal cartridge part no. 059183 or TRIPLEX cartridge part no. 057679 can be used.



Units with petrol engine are delivered with CO removal cartridge part no. 059183 as standard, units with electric engine with TRIPLEX cartridge part no. 057679. When changing from electric engine to a petrol engine also replace cartridge part no. 057679 with cartridge part no. 059183.



Never remove replacement cartridge from packaging prior to actual use otherwise highly sensitive molecular sieve will absorb water vapour from surrounding air and cartridge saturated and thus be ruined.

- Prior to changing the filter cartridge, drain condensate and depressurize filter system completely by opening condensate drain valves.
- Remove filter head (3, Fig. 32).
- Extract old cartridge and insert a new one.
- Screw in filter head to the stop without use of force.



The used cartridge must be disposed of according to local regulations.

FILLING VALVE MAINTENANCE

To protect filling valve against contamination a sintered metal filter is screwed in the filling valve body.

Remove filter insert and clean, if heavily soiled replace, as follows (refer to maintenance schedule, 4.3.):

- Unscrew pressure gauge from filling valve body.
- Screw off sintered metal filter with a suitable screw driver.
- To clean filter element, the best method is to use hot soapy water and to blow dry with compressed air. Replace if heavily soiled.
- Screw in filter element.
- Seal pressure gauge with PTFE tape or Loctite 243 and screw in tight to desired position.

1. Filter cartridge 057679: lifetime [hours]		
Filling pressure p = 200 bar		Junior II
Ambient temperature tU [°C]	Final separator temperature tAb [°C]	Delivery Q [l/min]
		100
10	20 - 24	26 - 21
15	25 - 29	20 - 16
20	30 - 34	15 - 12
25	35 - 39	11 - 9
30	40 - 44	9 - 7
35	45 - 49	7 - 6
40	50 - 54	5 - 5
Filling pressure p = 300 bar		Junior II
Ambient temperature tU [°C]	Final separator temperature tAb [°C]	Delivery Q [l/min]
		100
10	20 - 24	39 - 31
15	25 - 29	29 - 24
20	30 - 34	22 - 18
25	35 - 39	17 - 14
30	40 - 44	13 - 11
35	45 - 49	10 - 9
40	50 - 54	8 - 7

Filter cartridge 057679: bottle fillings [number] Molecular sieve mass mMS [g] = 68							
Ambient temperature tU [°C]	Final separator temperature tAb [°C]	Air humidity, saturated X [g/m ³]	Processable air volume Va [m ³] at pressure p [bar]		Number of bottle fillings n acc. to bottle size		
			200	300	7 l	10 l	12 l
10	20 - 24	17,31 - 21,80	157 - 125	236 - 187	112 - 89	79 - 62	65 - 52
15	25 - 29	23,07 - 28,79	118 - 94	177 - 142	84 - 67	59 - 47	49 - 39
20	30 - 34	30,40 - 37,63	89 - 72	134 - 108	64 - 52	45 - 36	37 - 30
25	35 - 39	39,65 - 48,64	69 - 56	103 - 84	49 - 40	34 - 28	29 - 23
30	40 - 44	51,21 - 62,41	53 - 44	80 - 65	38 - 31	27 - 22	22 - 18
35	45 - 49	65,52 - 79,28	42 - 34	62 - 51	30 - 25	21 - 17	17 - 14
40	50 - 54	83,08 - 99,85	33 - 27	49 - 41	23 - 19	16 - 14	14 - 11

Bottle volume VF [m ³]		
Bottle size	at pressure p [bar]	
l [litr.]	200	300
7	1,4	2,1
10	2	3
12	2,4	3,6

Number of bottle fillings n=

processable air volume / bottle volume = Va / VF

Bottle volume: VF [m³] = p [bar] x l [l] / 1000 [l/m³]

Processable air volume: Va [m³] = 0,2 x mMS [g] / (X [g/m³] / p [bar]) = 0,2 x p [bar] x mMS [g] / X [g/m³]

Filter cartridge lifetime: tp [h] = Va [m³] / (Q [m³/min] x 60 [min/h])

2. Filter cartridge 059183: lifetime [hours]		
Filling pressure p = 200 bar		Junior II
Ambient temperature tU [°C]	Final separator temperature tAb [°C]	Delivery Q [l/min]
		100
10	20 - 24	22 - 18
15	25 - 29	17 - 13
20	30 - 34	13 - 10
25	35 - 39	10 - 8
30	40 - 44	8 - 6
35	45 - 49	6 - 5
40	50 - 54	5 - 4
Filling pressure p = 300 bar		Junior II
Ambient temperature tU [°C]	Final separator temperature tAb [°C]	Delivery Q [l/min]
		100
10	20 - 24	34 - 27
15	25 - 29	25 - 20
20	30 - 34	19 - 15
25	35 - 39	15 - 12
30	40 - 44	11 - 9
35	45 - 49	9 - 7
40	50 - 54	7 - 6

Filter cartridge 059183: bottle fillings [number] molecular sieve mass mMS [g] = 58							
Ambient temperature tU [°C]	Final separator temperature tAb [°C]	Air humidity, saturated X [g/m³]	processable air volume Va [m³]		Number of bottle fillings n acc. to bottle size		
			at pressure p [bar]		7 l	10 l	12 l
			200	300			
10	20 - 24	17,31 - 21,80	134 - 106	201 - 160	96 - 76	67 - 53	56 - 44
15	25 - 29	23,07 - 28,79	101 - 81	151 - 121	72 - 58	50 - 40	42 - 34
20	30 - 34	30,40 - 37,63	76 - 62	114 - 92	55 - 44	38 - 31	32 - 26
25	35 - 39	39,65 - 48,64	59 - 48	88 - 72	42 - 34	29 - 24	24 - 20
30	40 - 44	51,21 - 62,41	45 - 37	68 - 56	32 - 27	23 - 19	19 - 15
35	45 - 49	65,52 - 79,28	35 - 29	53 - 44	25 - 21	18 - 15	15 - 12
40	50 - 54	83,08 - 99,85	28 - 23	42 - 35	20 - 17	14 - 12	12 - 10

Bottle volume VF [m³]		
Bottle size	at pressure p [bar]	
l [ltr.]	200	300
7	1,4	2,1
10	2	3
12	2,4	3,6

Processable air volume: $V_a [m^3] = 0,2 \times mMS [g] / (X [g/m^3] / p [bar]) = 0,2 \times p [bar] \times mMS [g] / X [g/m^3]$

Filter cartridge lifetime: $t_p [h] = V_a [m^3] / (Q [m^3/min] \times 60 [min/h])$

Number of bottle fillings n =
processable air volume / bottle volume = V_a / VF

Bottle volume: $VF [m^3] = p [bar] \times l [l] / 1000 [l/m^3]$

4.4.5. PRESSURE MAINTAINING VALVE

DESCRIPTION

A pressure maintaining valve is mounted at the outlet of the filter system P21.

It ensures that pressure is built up in the filter even from the start of delivery, thus achieving a constant, optimum filtration. It will also guarantee proper working conditions for the final stage cylinder.

The pressure maintaining valve is adjusted to **160 ±10 bar (2,320 psi)**.

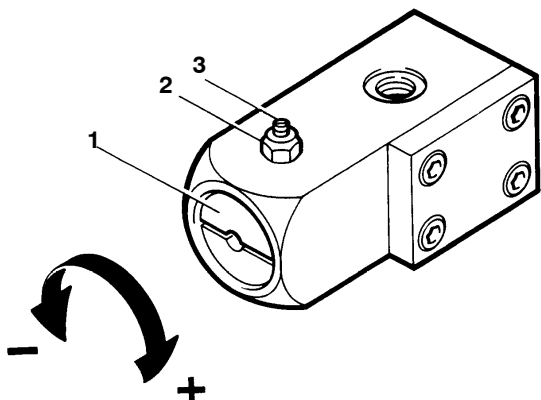

Fig. 34 Pressure maintaining valve

MAINTENANCE

The pressure maintaining valve (Fig. 34) is adjusted at the factory to the required pressure and normally does not require regular maintenance or readjustment. In case of readjustment becoming necessary, loosen jam nut (2) and set screw (3). Adjust screw (1) to the required pressure using a suitable screw-driver.



Clockwise = increase pressure
Counter-clockwise = decrease pressure

4.4.6. SAFETY VALVES

DESCRIPTION

All three compressor stages are protected by safety valves as follows

1st stage	9,9 bar
2nd stage	80 bar

The safety valve for protection of the last stage is mounted on top of the filter system P21 and is adjusted to the operating pressure of the unit (see chapter 1, Technical Data), **225**

bar for the standard units, **330 bar** for models -H or -HU. All safety valves are sealed at the factory.

If one of the intermediate pressure safety valves blows off, the valves in the next stage are not closing properly, affording valve check. The cause of the trouble is usually the inlet valve of the next stage. See also chapter 4.4.8.

MAINTENANCE

Checking function

Bauer-Kompressoren, as the manufacturer, recommends annual testing. We recommend replacement because intermediate pressure safety valves can only be tested with considerable expenditure. Replacement kits are available for our compressors from the customer service.

The final pressure safety valve has to be checked regularly. For this purpose the safety valve can be vented manually. Turn knurled knob on top of the valve clockwise until valve blows off (Fig. 35).

This just ensures that the valve is functional and will release pressure in case of a malfunction. To check the blow-off pressure value refer to "Blow-off pressure check".

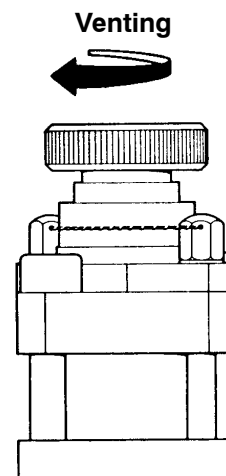

Fig. 35 Venting the final pressure safety valve

Checking blow-off pressure

Check blow-off pressure of the final pressure safety valve regularly, see maintenance schedule chapter 4.3. Pump unit to final pressure with shut-off valve closed until safety valve blows off. Check blow-off pressure of safety valve at pressure gauge. If deviation is 10% or more, replace safety valve.



We recommend that a final pressure setting of 80 % should not be exceeded, to avoid damaging the safety valve.

4.4.7. PRESSURE GAUGE

DESCRIPTION

The compressor unit is equipped with a final pressure gauge (Fig. 36). The red marking on it shows the max. allowable operating pressure.



Fig. 36 Final pressure gauge

MAINTENANCE

We recommend that the final pressure gauge is checked from time to time. For this purpose we have developed a special test pressure gauge with an adaptor which immediately recognizes any deviations in readings (see High Pressure Accessories Catalogue 8550/..).

Slight deviations during operation are normal and can be ignored. Excessive inaccuracy will require the pressure gauge to be replaced.

4.4.8. VALVES

DESCRIPTION

The valve heads of the individual stages form the top part of the cylinders. The intake and pressure valves are fitted inside the valve heads. Note that the valves are operated by the flow of the air.

On the suction stroke, the intake valves open and the air flows into the cylinders. At the start of the compression stroke the intake valve closes and the air opens the pressure valve, Fig. 37.

Intake and pressure valve of the 1st stage is a plate valve (Fig. 38).

INITIAL OPERATIONAL CHECK

After maintenance work on the valves, valves should be checked. Note that the intake line to the valve heads should be warm and outlet piping should be hot. Valves are then operating properly.

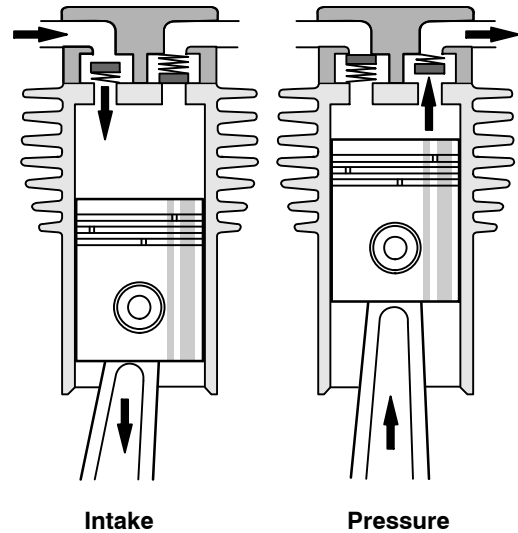

Fig. 37 Valve operation

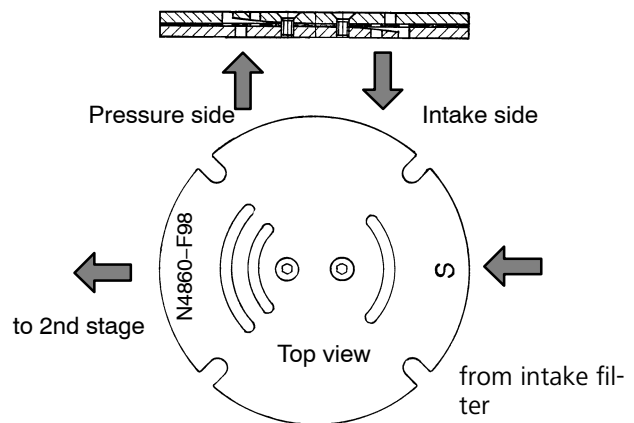

Fig. 38 Valve 1st stage

GENERAL INSTRUCTIONS FOR CHANGING THE VALVES

- **Always replace** valves as a complete set.
- **Observe** the correct sequence when fitting together again.
- **Check** individual components for excessive wear. If the valve seat and valve disks are dented, replace the valves.
- **Valve head screws** must be tightened with a torque wrench (see tightening torque values chapter 7.).
- **Check** the valve space in the valve heads for dirt and clean, if necessary.
- **30 minutes after restarting** the compressor stop unit, let it cool down to ambient temperature and retighten valve studs and cap nuts. Otherwise valves could work loose due to setting of the gaskets.
- **Use only** satisfactory gaskets and O-rings on reassembly.
- **After finishing** all maintenance work on the valves, turn the compressor manually using the flywheel and check whether all items have been correctly installed.

CHANGING THE VALVES OF THE 1ST STAGE

Intake and pressure valves of the 1st stage are combined in one plate valve under the valve head, see Fig. 39.

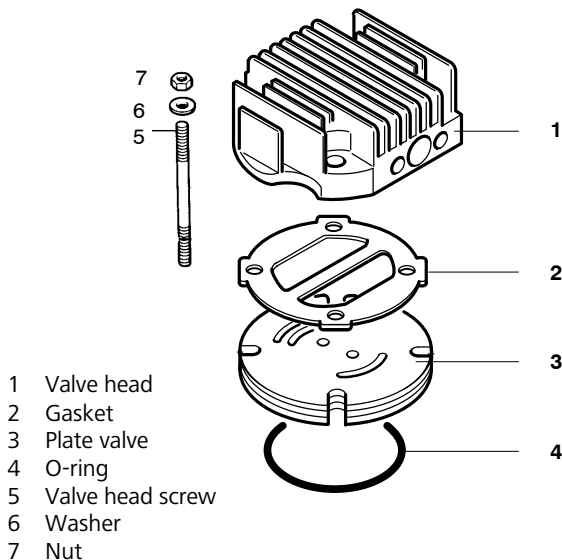

- 1 Valve head
- 2 Gasket
- 3 Plate valve
- 4 O-ring
- 5 Valve head screw
- 6 Washer
- 7 Nut

Fig. 39 Valve head 1st stage

- Loosen two cap nuts from tube connectors at valve head and safety valve connector and remove inter-cooler.
- Remove four valve head screws (5) from valve head (1). Take off valve head.
- Remove gasket (2) and plate valve (3).
- When re-installing the valve, check that mark "S" is facing upwards and towards intake filter side. The crossbar of gasket (2) seals the intake opening with respect to the two outlet openings of the pressure valve.

CHANGING THE VALVES OF THE 2ND STAGE

Both, pressure and intake valves can be serviced from outside, see Fig. 40.

- Remove two captive nuts (1) and spring-washers (2).
- Remove plate (3).
- Remove valves (4) and (7) using two screw-drivers as shown in Fig. 42.
- Assemble in reverse sequence. Position spring-washers with curved side facing upwards. Fasten nuts so that plate (3) is parallel to the valve head. Torque with 10 Nm (1 kpm).

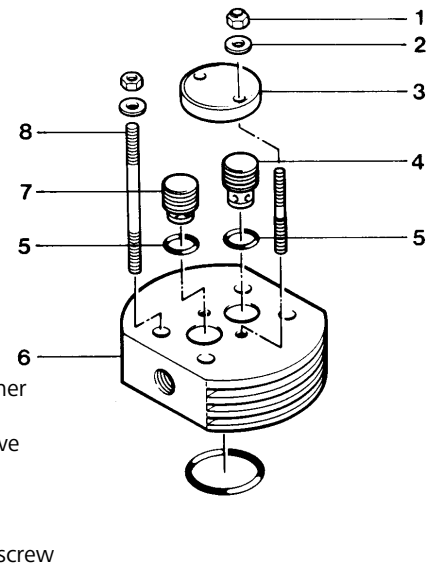

- 1 Nut
- 2 Spring-washer
- 3 Plate
- 4 Pressure valve
- 5 O-ring
- 6 Valve head
- 7 Intake valve
- 8 Valve head screw

Fig. 40 Valve head 2nd stage

CHANGING THE VALVES OF THE 3RD STAGE

On this valve head, the valves are arranged on the upper and lower side due to the small diameter of the 3rd stage, see Fig. 41.

For removal and installation of the intake valve (4) use special tool which is also part of the tool set delivered with the unit. Pressure valve (3) is merely inserted into valve head (5). It is sealed by O-ring (2) and fixed to the valve head by bolt (1).

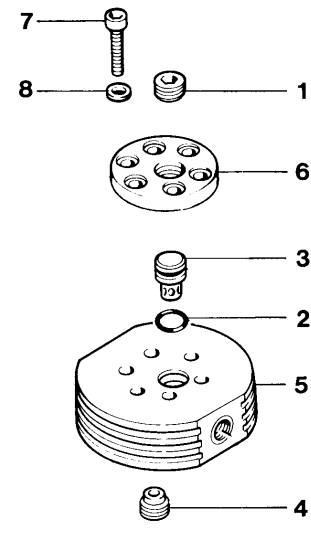

- 1 Torque stud
- 2 O-ring
- 3 Pressure valve
- 4 Intake valve
- 5 Valve head
- 6 Valve head cover
- 7 Allen screw
- 8 Gasket

Fig. 41 Valve head 3rd stage

Change intake and pressure valve of 3rd stage together only.



Remove or 3rd stage pressure valve (3) according to Fig. 41.

- Unwind torque stud (1) a couple of turns.
- Remove allen screws (7), take off valve head cover (6).
- Put two screwdrivers into the groove of pressure valve body (Fig. 42). If necessary turn valve loose at first using a 13 mm spanner on the flat surfaces.
- Lift out pressure valve (3) together with O-ring (2).

Reinstall pressure valve (3) in reverse sequence:

- Check O-ring for abrasion and replace if necessary. Put O-ring (2) into valve head (5).
- Insert pressure valve (3). Install valve head cover (6).
- Fasten valve head with allen screws (7) and washers (8).
- Screw in torque stud (1) with 20 Nm (2 kpm).

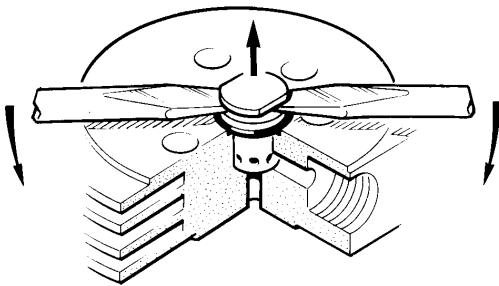

Fig. 42 Removal of 3rd stage pressure valve

4.4.9. COMPRESSOR DRIVE SYSTEM

DESCRIPTION

The compressor is driven by the drive motor through a V-belt. The motor is mounted on the base plate and requires adjustment for proper V-belt tension.



Improper v-belt tension and adjustment of the pulleys will result in extreme v-belt abrasion and premature wear.

MAINTENANCE

Checking the drive belt tension

- The best tension for a belt drive is the lowest possible, where the belt under full load does not slip. A rough value for this is when the belt deflects **10 mm** when pressed with thumb pressure between the two pulleys (Fig. 43). For best results we recommend our v-belt tension meter, part no. N25238.

V-belt tension adjustment

- Slightly loosen motor mounting nuts
- Adjust motor until the belt tension is correct (see Fig. 43).
- Tighten motor mounting nuts.
- Run motor for approx. 5 minutes. Stop motor, check V-belt tension, and readjust if required.

- Check that after tension adjustment and tightening the motor mounting nuts, both pulleys are in a straight line to avoid excessive wear of the V-belt. Hold a straight edge against compressor and motor V-belt pulleys as shown in Fig. 44: edge must be parallel to the v-belt.

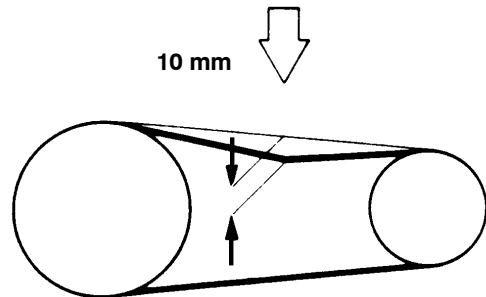

Fig. 43 Checking V-belt tension

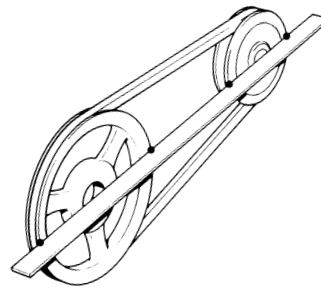

Fig. 44 V-belt pulley adjustment

4.4.10. AUTOMATIC CONDENSATE DRAIN (OPTION)

DESCRIPTION

The automatic condensate drain unit (Fig. 45) drains the intermediate separators and the oil and water separator after the last stage every 15 minutes during operation. In addition, the automatic condensate drain is designed to drain these filters after shut-down of the compressor unit and to unload the compressor during the starting phase.

The automatic condensate drain system operates electro-pneumatically and comprises the following main items:

- One solenoid valve, normally open type, functioning as condensate drain valve after the 2nd stage
- One pneumatically operated condensate drain valve, normally open type for the oil and water separator after the last stage
- A condensate manifold
- A condensate separator/silencer
- An electrical timer (in the control box on electric models)

The normally open condensate drain valves are connected in cascade mode. The condensate from the intermediate separator after the 2nd stage is applied to the solenoid valve. The solenoid valve is normally open. The condensate from the oil and water separator and purifier is applied to the pneumatically operated condensate drain valve. Before compressor start-up, the solenoid valve is open and the

condensate drain valve is open as well because there is no control air available at this moment. At start-up of the compressor, the solenoid valve is energized and closes: due to build-up of pressure by compressor operation, control air flows into condensate drain valve. The servo-piston is pressed onto the valve seat and the condensate drain valve closes. The compressor builds up pressure and delivers to the consuming devices.

Every 15 minutes, 3/2-way solenoid valve is deenergized for approx. 6 seconds by the timer. The solenoid valve opens and drains the condensate from the 2nd stage intermediate separator. Due to the pressure loss in intermediate separator the control pressure for condensate drain valve for the TRIPLEX filter is also removed. The servo-piston of the condensate drain valve is unloaded, the control pressure vented through the relief port. The piston of the drain valve is raised by pressure from the filter, the valve opens, and condensate is drained. After 6 seconds, the solenoid valve closes again, control pressure builds up at drain valve, and the valve closes.

CONDENSATE DRAIN PIPING AND COLLECTOR

The outlet opening of the condensate drain manifold is connected to a condensate drain separator. It separates the condensate from the air escaping together with the condensate from the filters. The air passes through a silencer and is released into the open air.

Due care must be taken to ensure that any oil which may be drained with the condensate will not pollute the environment. For example, the drain pipe can be directed into a collecting vessel or into drain facilities incorporating oil separators.



Dispose of condensate according to local regulations!

MAINTENANCE

The condensate drain valve for the oil and water separator is fitted with a manual drain valve to check correct operation of the automatic system.

- Open the manual drain valve (10, Fig. 45) once a week. This must be carried out immediately after the automatic system has drained the condensate. Observe the drainage of condensate when opening the manual drain valves. If the system drains a lot of condensate this is a sign that the system or the corresponding condensate drain valves are not working properly or that condensate drain intervals are too long. Find the fault and remedy accordingly. If hardly any condensate emerges, the automatic system is operating properly. For fault correction, see also chapter 4.5. "Troubleshooting".

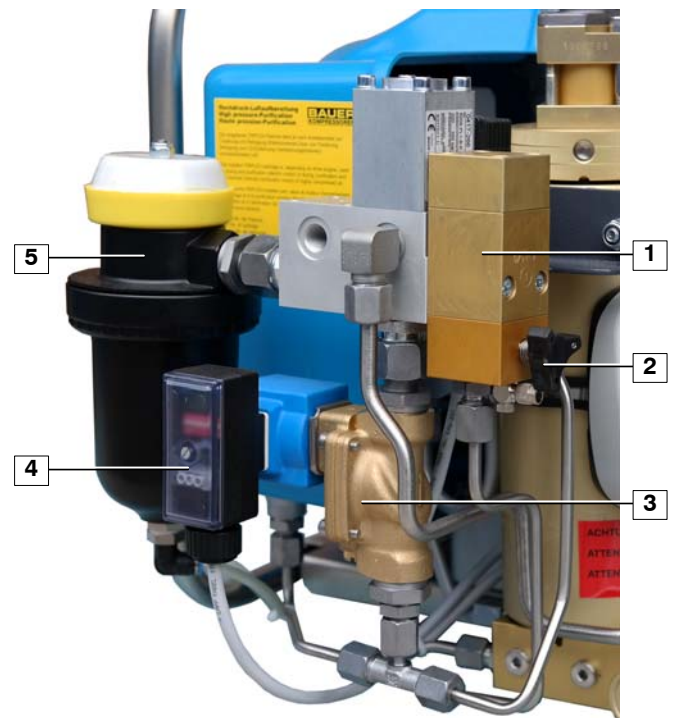

- 1 Condensate drain valve, 3rd stage
- 2 Manual drain tap
- 3 Solenoid valve, condensate drain 2nd stage
- 4 Timer (petrole unit)
- 5 Condensate separator/silencer

Fig. 45 Automatic condensate drain unit

4.4.11. ELECTRICAL SYSTEM

DESCRIPTION

This section describes the standard electrical system. The amount of built-in components varies depending on order.



For schematic diagram, see annex.

The electrical equipment of the compressor unit consists of:

- drive motor
- electric control system/motor protection switch

To start the electric motor and enable the functioning of the electric control, the following components are essential:

- main switch and main fuse, both to be installed by the customer.

DRIVE MOTOR

The compressor unit is driven by an alternating or a three phase current motor by means of a V-belt.

MOTOR PROTECTION SWITCH (ALTERNATING CURRENT MOTOR)

Protection of the motor is ensured by the releases integrated into the motor protection switch (1, Fig. 46). The response value is preset. The motor is switched on manually by pressing the 0-I switch to I. For safety of the operating personnel all voltage carrying parts have a protective cover.

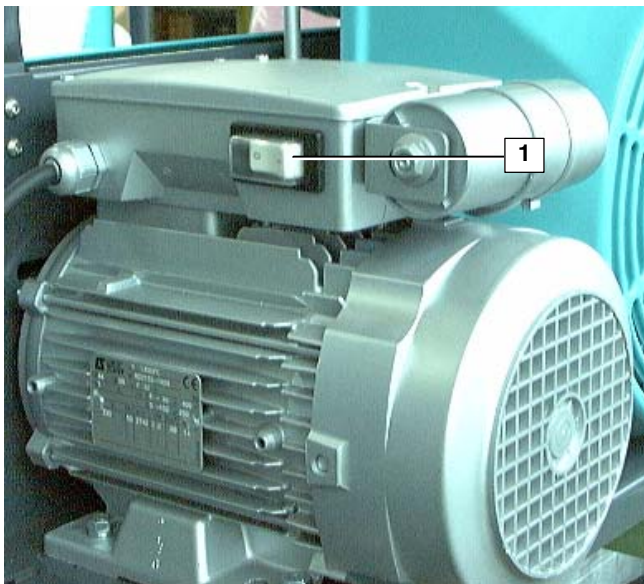

Fig. 46 Motor protection switch (alternating current)

MOTOR PROTECTION SWITCH (THREE-PHASE MOTOR)

The motor is switched on manually by turning the switch to 1 (Fig. 47). It is switched off manually by turning the switch to 0.

For safety of the operating personnel all voltage carrying parts have a protective cover.



After the switch has shut off by overcurrent triggering, the motor can be restarted by pressing the start-button not before the bi-metal in the switch has cooled down. This may last a couple of minutes.

Protection of the motor is ensured by the thermomagnetic releases integrated into the motor protection switch. The response value of the electromagnetic releases (protection against short-circuit) is preset.

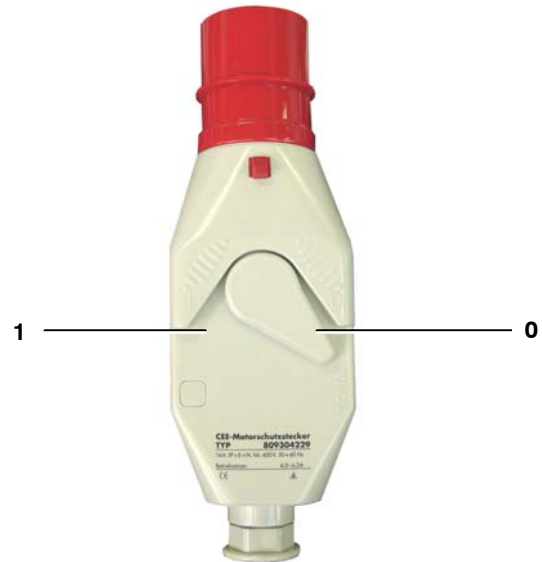

Fig. 47 Motor protection switch (three-phase motor)

SEMI-AUTOMATIC COMPRESSOR CONTROL (OPTIONAL)

Unit switches off automatically when the final pressure is reached in the pressure system connected to the compressor. Restart the unit manually by pressing operation button 1 on the control and monitoring unit.

The compressor control comprises following components:

- Motor protection switch Q1
- Final pressure switch K1 (K3 optional)
- Timer for the condensate drain unit Q2
- Rotational direction monitoring Q3 (three phase units only)

- Overload relay F3 (three phase units only)

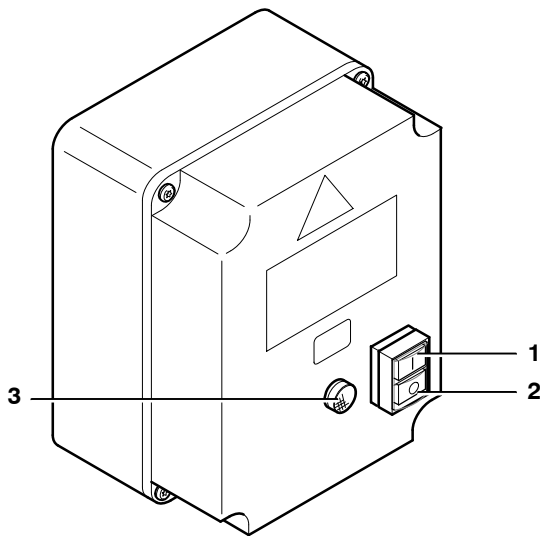

Fig. 48 Compressor control

- 1 Start push-button (I)
- 2 Stop push-button (O)
- 3 Warning lampe, rotational direction monitoring

Final pressure switch

Switching **on** and/or **off** of the compressor unit is controlled by pressure switch F16. The upper threshold value is adjustable as follows.

OFF max. = 350 bar^{a)} **OFF min. = 200 bar**

The pressure switch is adjusted to the corresponding pressure according to order. In case of readjustment becoming necessary, open cover (2, Fig. 49). Adjust screw (1) to the required pressure using a 6 mm allen key.

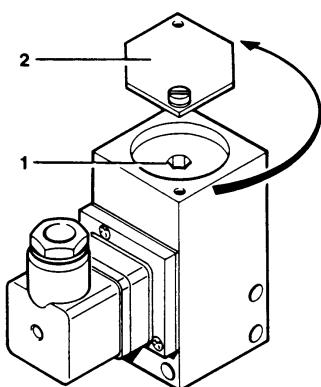

Fig. 49 Final pressure switch

Electrical connection of the automatic condensate drain (optional)

For electrical connection of the automatic condensate drain see the schematic diagram in the annex of this manual. The amount of built-in components varies depending on order.

- Max. possible setting value; for max. allowable value refer to chapter Technical data



The factory set condensate drain intervals are valid for 20 °C (68 °F) air temperature of the surrounding air. It is possible to shorten the condensate drain interval when operating the unit at a higher temperature.

Standard setting condensate drain

- Drain interval = 15 min.
- Drain time = 6 s.

Adjusting the timer (units with electric motor)

Timer Q2 controls the automatic condensate drain unit.

Q2 is an industrial timing relay with 1 single pole, double throw contact. The drain interval and drain period is set with controls t1 (1, Fig. 50) and t2 (2). t1 is factory set to 15 minutes, t2 to a drain time of 6 seconds.

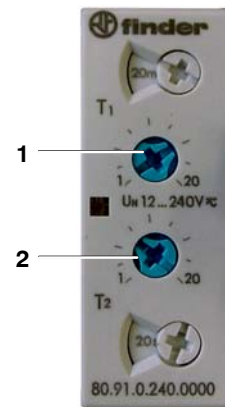

Fig. 50 Timer Q2 (electric units)

Adjusting the timer (units with petrol engine)

Adjust the electric timer as follows:

- Remove cover by undoing the screw.
- Ensure that DIP switches 1 to 8 (1, Fig. 51) at timer are set to OFF.
- Place DIP switches 3 and 8 to ON as shown in A, Fig. 52. In this preliminary configuration, the condensate drain interval can be adjusted in seconds from 1,5...30 s.
- Switch on power.
- Adjust switch-on time with potentiometer t_{on} assigned to DIP switches 1 to 3 (preliminary 15 seconds). Turn potentiometer fully ccw. The desired switch-on time of 15 seconds within the range setting of 1.5 to 30 seconds is approx. between 5 and 7 o'clock (Fig. 53). The exact position has to be found with a stop watch.
- Then adjust drain time with potentiometer t_{off} assigned to DIP switches 6 to 8 (6 seconds). Turn potentiometer fully ccw, then start turning cw. The desired switch-on time of 6 seconds within the range setting of 1.5 to 30 seconds is approx. between 2 and 4 o'clock (Fig. 53). The exact position has to be found with the stop watch.

- Finally place DIP switches 3 to OFF and 1 to ON as shown in B, Fig. 52. In this configuration the preliminary condensate drain interval is converted in a range setting of 1.5 to 30 min. The setting of time is proportional: setting 15 sec in the time range 1.5...30 sec (preliminary setting) becomes 15 min when changing the range to 1.5...30 min (final setting). The operating time will now be 15 minutes.



Fig. 51 Condensate drain timer (petrol units; Bürkert)



Fig. 52 DIP switch adjustment

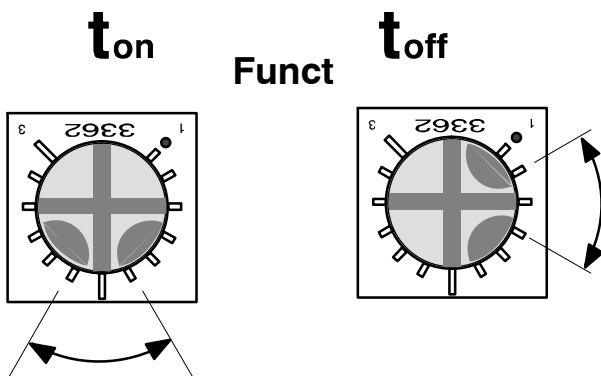

Fig. 53 Potentiometer setting

UNITS WITH PETROL ENGINE

Description of drive engine see instruction manual of SUBARU petrol engine delivered with the unit.

MAINTENANCE

For the electrical system no regular maintenance is required.

4.4.12. COOLING SYSTEM

The cylinders of the compressor block, the intermediate coolers and the after-cooler are air-cooled.

For this purpose, the compressor is equipped with a fan-wheel connected to the counter-weight at the crankshaft end opposite to the V-belt pulley. It draws the cooling air through the fanwheel cover from the surroundings.

Refer to chapter 3. for proper installation and cooling air supply. For maximum ambient temperature, see Technical Data, chapter 1.

4.5. TROUBLE-SHOOTING

Trouble	Cause	Remedy
Drive motor (electric)		
Motor will not start	Electric circuitry faulty	Check all fuses, terminal connections, wire leads, make sure that motor data complies with mains supply
Motor/engine runs eccentrically	V-belt worn	Replace
Motor protection switch is switching off the unit	Wrong adjustment of the motor protection switch	Set to nominal motor current. Observe temperature compensation (+20 °C =1,0) For ambient temperature + 10 °C : correction factor 0,94 + 30 °C : correction factor 1,05 + 40 °C : correction factor 1,12
	Uninsufficient voltage because of weak power supply	Switch off other consuming devices
Motor protection switch is switching off the unit	Power supply cable too long or too thin	Use suitable cable
Drive motor (petrol)		
Motor will not start	See motor instructions	See motor instructions
Motor runs eccentrically	V-belt worn	Replace
Motor stops	Low oil level	Top up oil
Drive system		
Excessive v-belt wear (black deposits on belt guard)	V-belt tension	Re-tighten, see chapter 4.4.9.
	Pulleys not aligned	Re-adjust, see chapter 4.4.9.
Compressor		
Compressor does not attain final pressure	Condensate drain valve(s) leaking	Tighten and reseal
	Final pressure safety valve defective (blows too soon)	Replace safety valve
	No cartridge in filter system P21 (air escaping through cartridge safety bore)	Replace cartridge
	Vent screw for final pressure safety valve not in operating position	To vent, unscrew until completely open
Air delivery drops	Intake filter soiled	Clean or replace filter cartridge
	Pipe coupling leaking	Retighten couplings
	Excessive wear of 3rd stage piston	Replace piston and sleeve of 3rd stage
Intermediate pressure safety valve blows	Intermediate pressure too high because of defective inlet or pressure valve of the following stage	Check/replace inlet or pressure valve
	Safety valve leaking	Replace safety valve
Compressor overheats	Insufficient cooling air	Check location; ensure proper cooling air flow
	Ambient temperature too high	Check location; ambient temperature max. +45 °C (113 °F)
	Direction of rotation is wrong	Correct direction of rotation
	Inlet and pressure valve of one stage is leaking	Check valves, clean/replace if necessary
Taste of oil in the air	TRIPLEX cartridge saturated	Replace cartridge
	Unqualified lubricant being used	Replace oil with an approved brand

Trouble	Cause	Remedy
High oil consumption	Piston rings, Pistons or cylinders worn out	Replace defective parts
	Intake filter clogged	Replace filter cartridge
	Compressor too hot	Enhance cooling
Air escaping through cartridge safety bore	Cartridge missing	Insert cartridge
	Cartridge installed but O-rings defective	Check/replace O-rings
Electric		
Control does not switch on	No control voltage	Check feed line
	Control fuse defective	Replace fuse, eliminate cause
	Control current line cut off, line or terminal loose	Tighten terminal
	Thermal overload triggered	Clear faults as described in the following
Thermal overload relay for drive motor triggered	Current consumption too high	Check compressor drive
	Overload relay set too low	Correct setting
Control does not switch off, final pressure safety valve blows off	Final pressure switch set too high	Correct setting
	Final pressure safety valve defective	Replace safety valve
Automatic Condensate Drain (optional)		
Drain valve does not close	No control air	Check control air line
	Drain valves leaking	Dismantle drain valve and clean
Drain valve do not open	Condensate drain valve piston jammed	Dismantle drain valve, clean or replace valve
Solenoid valve does not close	Solenoid valve faulty	Check solenoid valve and replace if necessary
	No electrical signal	Check for voltage and timer
Solenoid valve does not open	Solenoid valve faulty	Check solenoid valve and replace if necessary
	Continuous electrical signal	Check electrical control circuit and timer
Unsatisfactory drainage (lot of condensate from manual valves)	Nozzle in 3rd stage drain valve clogged	Remove nozzle, clean Note: 3rd stage 0,8 mm Ø

5. TRANSPORT, STORAGE, PRESERVATION

TRANSPORT

- Always unplug the power supply before transporting the unit, even in case of slight displacements.
- Before transporting, always depressurise the compressor by means of condensate drain taps.
- Before transporting, stow loose parts safely.
- Always have two people carry the unit by using the handle.

PREPARATION FOR STORAGE

If the compressor is put out of service for more than six months, the unit should be preserved in accordance with the following instructions: Make sure the compressor is kept indoors in a dry, dust free room. Only cover the compressor with plastic if it is certain that no condensation will form under the sheet. Nevertheless, the sheet should be removed from time to time and the unit cleaned on the outside. If this procedure cannot be followed and/or the compressor is going to be taken out of service for more than 2 years, please contact our Technical Service Department for special instructions.



The compressor is not resistant to salt-water! If not in use keep unit in a dry place.

Before preserving the compressor unit, run it warm and when it reaches the specified service pressure, keep it running for approx. 10 minutes.

Then carry out the following:

- Check all pipes, filters and valves (also safety valves) for leakage.
- Tighten all couplings, as required.
- After 10 minutes, open the filling valves or the outlet valve and run the compressor at the set minimum pressure (pressure maintaining valve, see chapter 4.4.5.) for approx. 5 minutes.
- After these 5 minutes, shut the system down. Drain condensate from separators. Depressurize unit. Shut filling valves.
- Open filters and grease threads.
- **Ensure that filter cartridge remains in the filter!** This will prevent oil entering filling lines as a result of preservation procedures.
- Remove intake filter from manifold and all intake lines from valve heads.
- Let compressor unit cool down.

PRESERVING THE COMPRESSOR

- Turn the compressor on and spray a small amount (approx. 10 ccm/0.6 cu. in.) of compressor oil into the valve head inlet port while the compressor is running. Do not let the compressor warm up too much, to keep oil sticky.
- Shut compressor unit off.
- Close all valves.
- Place the dust cap onto the inlet port.

PRESERVING THE MOTOR/ENGINE

Preserve the motor/engine according to the instructions of the motor/engine manufacturer.

PREVENTIVE MAINTENANCE DURING STORAGE

Run the compressor **once every 6 months** as described in the following:

- Remove the dust cap from the inlet port and insert the intake filter.
- Open the filling valves or the outlet valve and let the unit run for approx. 10 minutes or until the pressure gauges indicate the correct values.
- Stop the compressor.
- Open condensate drain valves and release compressed air. Close condensate drain valves again.
- Carry out preservation procedure according to chapter "preserving the compressor"

Changing the lube oil for preserving

- After prolonged storage, the oil will age in the compressor and engine. It should be drained after **2 years** at the latest and replaced with fresh oil.
- The stated period can only be attained when the crankcase is sealed during the preservation period in accordance with the preservation requirements.
- After changing the oil, turn the compressor and the engine or run them for the required period.
- Check the lubrication of the compressor when putting the unit into operation once every six months or when turning the compressor. The oil pump is functioning properly when oil can be seen flowing through the sight glass of the oil pressure regulator and if the oil pressure gauge indicates the prescribed pressure.

REACTIVATING THE COMPRESSOR UNIT

- Remove the dust cap from the inlet port and insert the intake filter.
- Check the oil level of the compressor.
- Check the motor/engine according to the manufacturer's instructions.
- Open the purifier and change all filter cartridges.
- Run the compressor warm with open filling valves or outlet valve for approx. 10 minutes.
- Check the oil pressure on the pressure gauge. If there is any fault, check the lubrication of the compressor.
- After 10 minutes, close the filling valves or the outlet valve and run the unit up to final pressure until the final pressure safety valve blows.
- Check the inter-pressure safety valves for leakage.
- Establish cause of any fault from the trouble-shooting table, chapter 4.5., and take corrective action.
- Stop the system when running properly, the compressor is then ready for operation.

6. REPAIR INSTRUCTIONS

GENERAL

Preventive maintenance usually involves replacing the valves, gaskets and sealing rings as well as carrying out the maintenance work. Repair work can be carried out on the compressor block to a certain extent but a certain experience and skill is necessary. It should be noted, however, that

- no repair should be carried out on the crankdrive nor on the bearings
- safety valves are not repaired but always replaced completely.

For many **BAUER** compressor units, workshop manuals are available through our customer service.

For questions on maintenance and repair, please contact our technical service department.

7. TABLES

TIGHTENING TORQUE VALUES



Unless otherwise specified in text, the following torque values apply. All valve head screws require torque wrench tightening! The indicated torque values are valid for bolts in greased condition. Replace self-retaining nuts on reassembly.

Bolt or screw	Thread	max. torque
Hex and allen head	M 6	10 Nm (7 ft.lbs)
Hex and allen head	M 8*	25 Nm* (18 ft.lbs)
Hex and allen head	M 10	45 Nm (32 ft.lbs)
Hex and allen head	M 12	75 Nm (53 ft.lbs)
Hex and allen head	M 14	120 Nm (85 ft.lbs)
Hex and allen head	M 16	200 Nm (141 ft.lbs)
Pipe connections (swivel nuts):		Finger-tight + 1/2 turn

TORQUE SEQUENCE

Tighten valve head and cylinder bolts/nuts equally in the sequence shown in Fig. 54.

Be sure to tighten all parts in **cold** condition only.

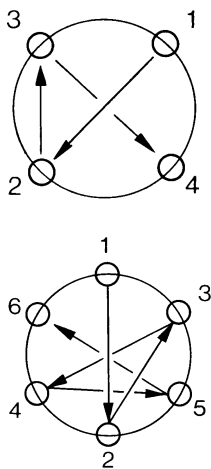

Fig. 54 Torque sequence

* Exception: mounting bolts of final pressure safety valve: 10 Nm

LUBRICATION CHART

Usage	Lubricants
Rubber and plastic parts, filter housing threads	WEICON WP 300 WHITE part no. N19752 or BAUER special grease part no. 072500
Sealing rings	BAUER special grease part no. 072500
Shaft seal (seal) Shaft seal (shaft)	BAUER special grease part no. 072500 Klüber SK 01-205
Screws, bolts, threads	WEICON ANTI-SEIZE AS 040 P part no. N19753 or equivalent compound with copper or MoS ₂ additives

For compressor lubricating oils refer to oil list in chapter 8.

ADHESIVE AND SEALANT CHART

Usage	Adhesives and Sealants
Screws	Loctite 2701
Seals for conical threads	Loctite 243
Metal - metal seals High temperature connections, e.g. valve heads, cylinders	Temperature resistant compound, e.g. WACKER E10, part no. N18247
Paper gaskets	Loctite FAG 2

TESTING AGENTS

Usage	Testing agents
Tube connectors, tubes	Leakage test spray, part no. FM0089

8. ANNEX

- Schematic diagram
Lubricating oil list
Parts list

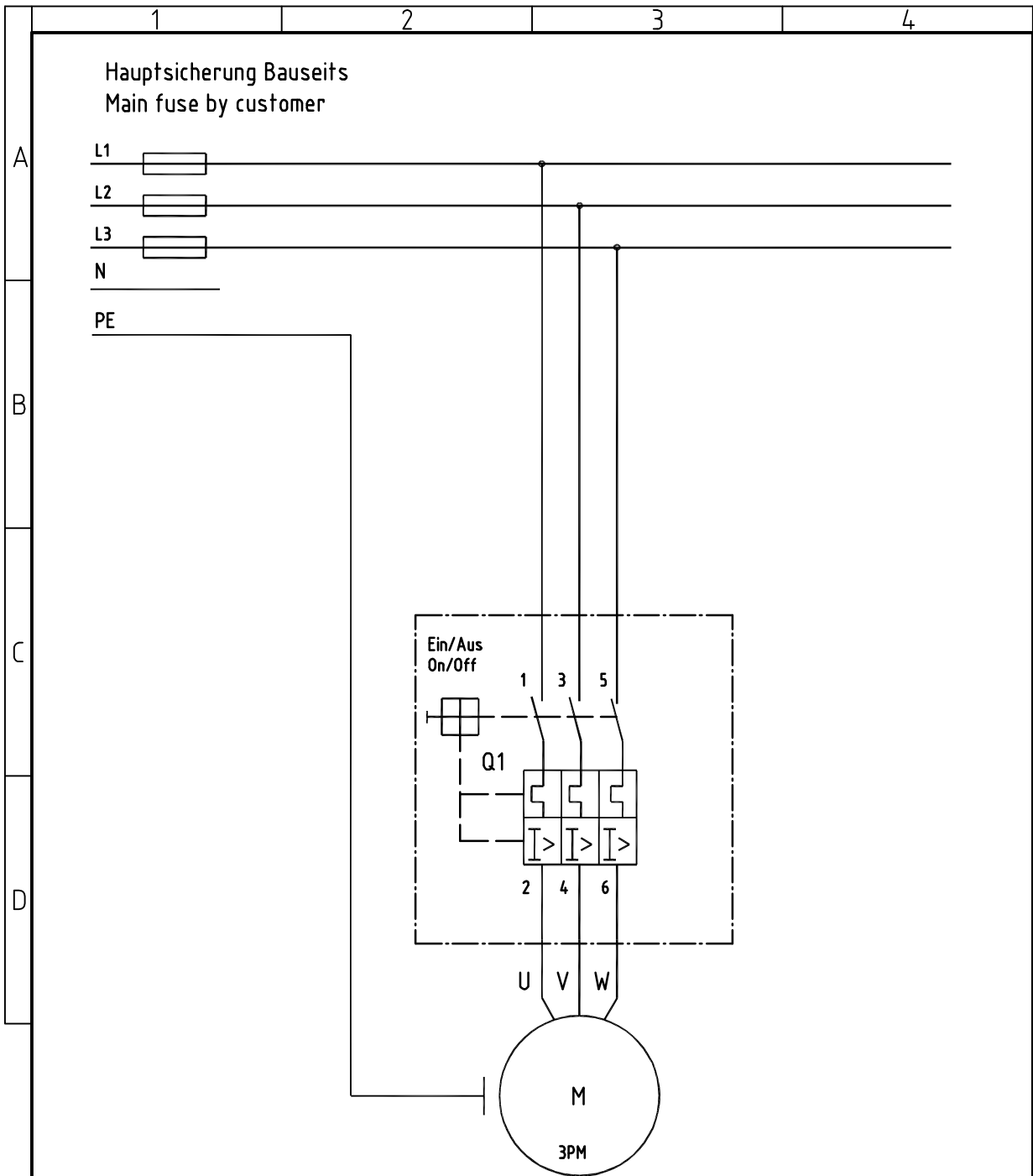

Für diese techn. Unterlage wird jeglicher gesetzlich vorgesehene Rechtsschutz nach DIN 34 in Anspruch genommen.			zul. Abw. ISO 2768 mH	Oberfläche DIN ISO 1302	Masstab: 1:1	Masse:
			Datum	Name	Werkstoff:	
			Gez. 15.02.2008	GROTTHUS	Benennung: Schaltplan Motorschutzschalter	
			Gep. 15.02.2008	GROTTHUS		
			Freig. 19.02.2008	EDBCUSTO		
			BAUER KOMPRESSOREN		Zeichnungs-Nr.	76942-01-SP
					Blatt 0	
ab						
Zust.	Änderung	Datum	Name			

