

Ersatzteilliste
Spare parts catalogue
Catalogue des pièces

TM320-1/0

Atemluft-Kompressoranlagen
Breathing air compressor units
Groupes compresseurs à air respirable

Mariner 320



TEILELISTE TM320-1/0

ist gültig ab Juli 2002
für Kompressortyp

MARINER 320

PARTS LIST TM320-1/0

is valid as of July 2002
for compressor model

MARINER 320

CATALOGUE DES PIECES TM320-1/0

est valable à partir de Juillet 2002
pour les compresseurs de type

MARINER 320

<u>Baugruppe</u>	<u>Assembly</u>	<u>Assemblage</u>	<u>Abb./fig.</u>
Kurbelgehäuse mit Zubehör	Crankcase with accessories	Carter avec accessoires	TM320-1
Triebwerk	driving gear	embiellage	
Kolben, Zylinder 1./2. Stufe	Pistons, cylinders 1st/2nd stage	Pistons, cylindres 1e/2e étage	TM320-2
Kolben, Zylinder 3. Stufe	Pistons, cylinders 3rd stage	Pistons, cylindres 3e étage	TM320-3
Kolben, Zylinder 4. Stufe	Pistons, cylinders 4th stage	Pistons, cylindres 4e étage	TM320-4
Ventilkopf, 1. Stufe	Valve head, 1st stage	Culasse de 1er étage	TM320-5
Ventilkopf, 2. Stufe	Valve head, 2nd stage	Culasse de 2e étage	TM320-6
Ventilkopf, 3. Stufe	Valve head, 3rd stage	Culasse de 3e étage	TM320-7
Ventilkopf, 4. Stufe	Valve head, 4th stage	Culasse de 4e étage	TM320-8
Schwungrad	Flywheel	Volant	TM320-9
Zwischenfilter	Intermediate separator valves	Séparateur intermédiaire	TM320-10
Zwischenfilter	Intermediate separator valves	Séparateur intermédiaire	TM320-11
Kühlung	Cooling system	Refroidissement	TM320-12
Druckölschmierung	Lubrication system	Lubrification	TM320-13
Ansaugfilter	Intake filter	Filtre d'aspiration	TM320-14
Kondensatablaßhahn	Condensate drain tap	Robinet de purge des condensats	TM320-15
Filtersystem P31	Filter system P31	Système de filtration P31	TM320-16
Filtersystem P41*	Filter system P41*	Système de filtration P41*	TM320-17
Fülleiste	Filling panel	Listeau de remplissage	TM320-18
Fülleiste mit Umschaltvorrichtung*	Filling panel with change over device*	Listeau de remplissage / dispositif sélecteur*	TM320-19
Fülleinrichtung 200 bar	Filling device 200 bar	Dispositif de remplissage 200 bar	TM320-20
Fülleinrichtung 300 bar	Filling device 300 bar	Dispositif de remplissage 300 bar	TM320-21
Rahmen	Frame	Châssis	TM320-22
Antriebsmotoren und Zubehör	Driving motors and accessories	Moteurs d'entraînement et accessoires	TM320-23
Kondensatablaßautomatik*	Automatic condensate drain*	Purge automatique des condensats*	TM320-24
Fahrsatz*	Undercarriage*	Chariot*	TM320-25
Elektrische Steuerung*	Electric control system*	Commande électrique*	TM320-26

*Zusatzausstattung *Optional extra *Optionnel

Wichtige Hinweise für Teilebestellung:

Bestell-Nr., die mit der Ziffer 0 beginnen, bezeichnen Baugruppen, die komplett geliefert werden. Teile ohne Bestell-Nr. sind nur zur Information für die Montage aufgeführt. Sie sind nicht als Ersatzteil erhältlich. Bei Ersatzteilbestellungen erwarten Sie unsere richtige Lieferung; deshalb benötigen wir von Ihnen folgende Angaben (siehe unten gezeigtes Typenschild):

1. Modellbezeichnung, Fabrik-Nr. sowie Fertigungsstand von Anlage/Block
2. Stückzahlen
3. Benennung und Best.-Nr. des gewünschten Teils

Bestell-Beispiel:

Für Kompressoanlage ...
Fabrik-Nr. 524-0528/1/2 drei Dichtungen
8263-090

Important notes for spare parts orders:

Part nos. beginning with digit 0 indicate parts available as complete assemblies. Parts without part no. are indicated for assembly reference, only. These parts are not available as single parts. When placing an order for spare parts, please give the following items so as to ensure our correct delivery (see identification plate shown below):

1. Model, serial no. as well as design standard of unit/block
2. Quantity required
3. Name and part no.

Example for order:

For compressor unit ...
serial no. 524-0528/1/2, three gaskets
8263-090

Avis important pour la commande de pièces:

Les nos. de commande commençant par le chiffre 0 indiquent les pièces livrées au complet. Les pièces sans no. de commande sont indiquées uniquement pour information de montage. Elles ne sont pas livrées individuellement. Pour que la livraison de pièces de rechange corresponde à la commande, veuillez bien nous fournir les données suivantes (voir plaque d'identité ci-dessous):

1. Modèle, no. de série et standard de construction de bloc compresseur/groupe
2. Quantité désirée
3. Dénomination et no. de commande de la pièce désirée

Exemple de commande:

Pour goroupe compresseur ...
no. de série 524-0528/1/2, trois joints no. de cde. 8263-090



Wartungssätze

- a = Wartungssatz 500 h bzw. bei Bedarf
- b = Wartungssatz 1000 h, mind. jährlich
- c = Wartungssatz 2000 h, mind. alle 2 Jahre



Maintenance kits:

- a = Maintenance kit 500 h or as required
- b = Maintenance kit 1000 h, at least annually
- c = Maintenance kit 2000 h, at least biennially



Kits de maintenance :

- a = Kit d'entretien 500 h ou au besoin
- b = Kit d'entretien 1000 h, au moins un fois par an
- c = Kit d'entretien 2000 h, au moins tous les 2 ans

In den Spalten sind die im entsprechenden Satz enthaltenen Teile angekreuzt. Bitte beachten, daß die höheren Sätze die untergeordneten nicht beinhalten, d.h. für eine 2000-Stunden-Wartung wird 1x Satz a, 1x Satz b und 1x Satz c benötigt.

The columns contain the parts that are included in the respective parts set. Please note that the higher graded kits do not include the lower ones, i.e. for a 2000 hours maintenance, one kit a, one kit b plus one kit c are required.

Les pièces contenues dans les kits correspondants sont marquées d'une croix dans les colonnes. Veuillez observer que les kits supérieurs ne contiennent pas les kits subordonnés, c'est-à-dire pour un entretien de 2000 heures il faut avoir 1x kit a, 1x kit b et 1x kit c.

Anmerkungen zur Identifikation:
Remarks for identification:
Remarques pour l'identification:

Modell/Model/Modèle		Fabrik-Nr./Serial no./Numéro de série	
<input type="text"/>		<input type="text"/>	
-		Jahr	<input type="text"/>
/		Year	<input type="text"/>
Volumenstrom m ³ /min	<input type="text"/>	n/min.	<input type="text"/>
Free air delivery Scfm	<input type="text"/>	r.p.m.	<input type="text"/>
Betriebsüberdruck bar	<input type="text"/>	kW	<input type="text"/>
Max. working press. psig	<input type="text"/>	CE	
		KB 73708	
		Fertigungsstand / Modification no. / No. de modification	
		Anlage/Unit/Groupe	
		Kompressorblock/ Compressor block/ Bloc compresseur	



ACHTUNG

Nur Schrauben und Stiftschrauben der Qualität 8.8 verwenden!



ATTENTION

Use only screws and studs in quality 8.8! This quality is equivalent to SAE J 429 d grade 5.



ATTENTION

N'utiliser que des vis et des goujons filetés de la qualité 8.8!

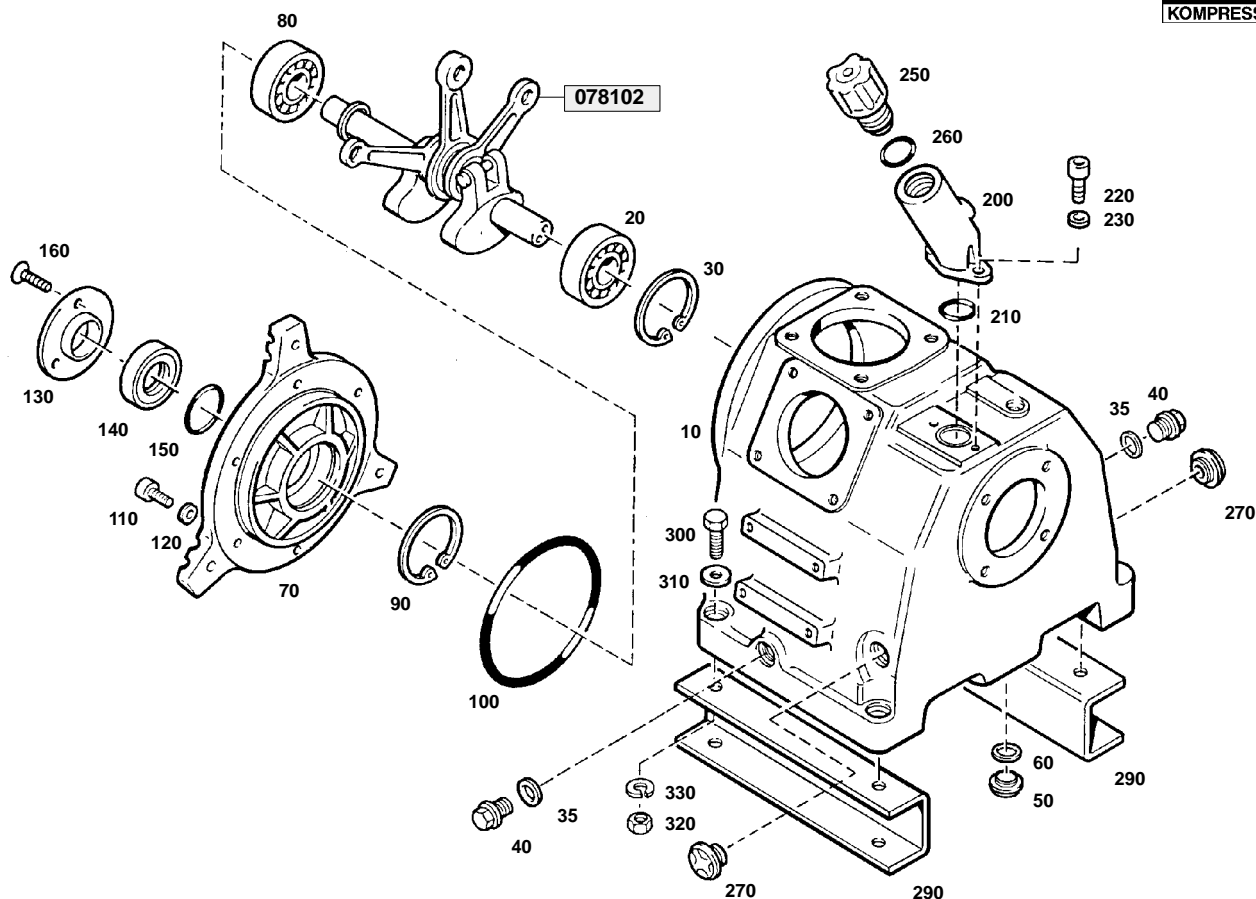
 Wartungssätze
 Maintenance sets
 Kits d'entretien

Baugruppe 076743
Assembly 076743
Assemblage 076743

Kurbelgehäuse, m. Zubehör, Triebwerk
Crankcase with accessories, driving gear
Carter avec accessoires, embiellage
TM320-1

Klasse/ Class/ Classe			Pos.	Bestell-Nr. Part No. No. de cde.	Anz. Qty. Qté.	Benennung	Designation	Dénomination
a	b	c						
			10	76740	1	Kurbelgehäuse	crankcase	carter
			20	N2638	1	Zylinderrollenlager	cylindrical roller bearing	roulement à rouleaux
			30	N2635	1	Sicherungsring	circlip ring	rondelle de sûreté
X			35	N4163	2	Dichtring	gasket	joint
			40	N2796	2	Verschlußschraube	plug	bouchon fileté
			50	N4570	1	Verschlußschraube	plug	bouchon fileté
			60	N1316	1	Dichtring	gasket	joint
			70	66209	1	Lagerdeckel	bearing cap	couvercle de palier
			80	N15406	1	Zylinderrollenlager	cylindrical roller bearing	roulement à rouleaux
			90	N2635	1	Sicherungsring	circlip ring	rondelle de sûreté
			100	N15265	1	O-Ring	o-ring	joint torique
			110	N756	6	Sechskantschraube	hexagon screw	vis hexagonale
			120	N58	6	Scheibe	washer	rondelle
			130	66684	1	Deckel	cover	couvercle
			140	N170	1	Wellendichtring	shaft seal	bague d'étanchéité
			150	N3745	1	O-Ring	o-ring	joint torique
			160	N16128	3	Senkschraube	countersunk screw	vis à tête fraisée
			200	73830	1	Öleinfüllstutzen	oil filling pipe	tubulure de remplissage
			210	N4776	1	O-Ring	o-ring	joint torique
			220	N88	2	Sechskantschraube	hexagon screw	vis hexagonale
			230	N58	2	Scheibe	washer	rondelle
			250	61054	1	Verschlußschraube	plug	bouchon fileté
			260	N15412	1	O-Ring	o-ring	joint torique
			270	N25475	2	Ölstandsauge	oil sight gauge	regard d'huile
			290	78038	2	Kompressorfuß	support	ped de compresseur
			300	N350	4	Sechskantschraube	hexagon screw	vis hexagonale
			310	N16	4	Scheibe	washer	rondelle

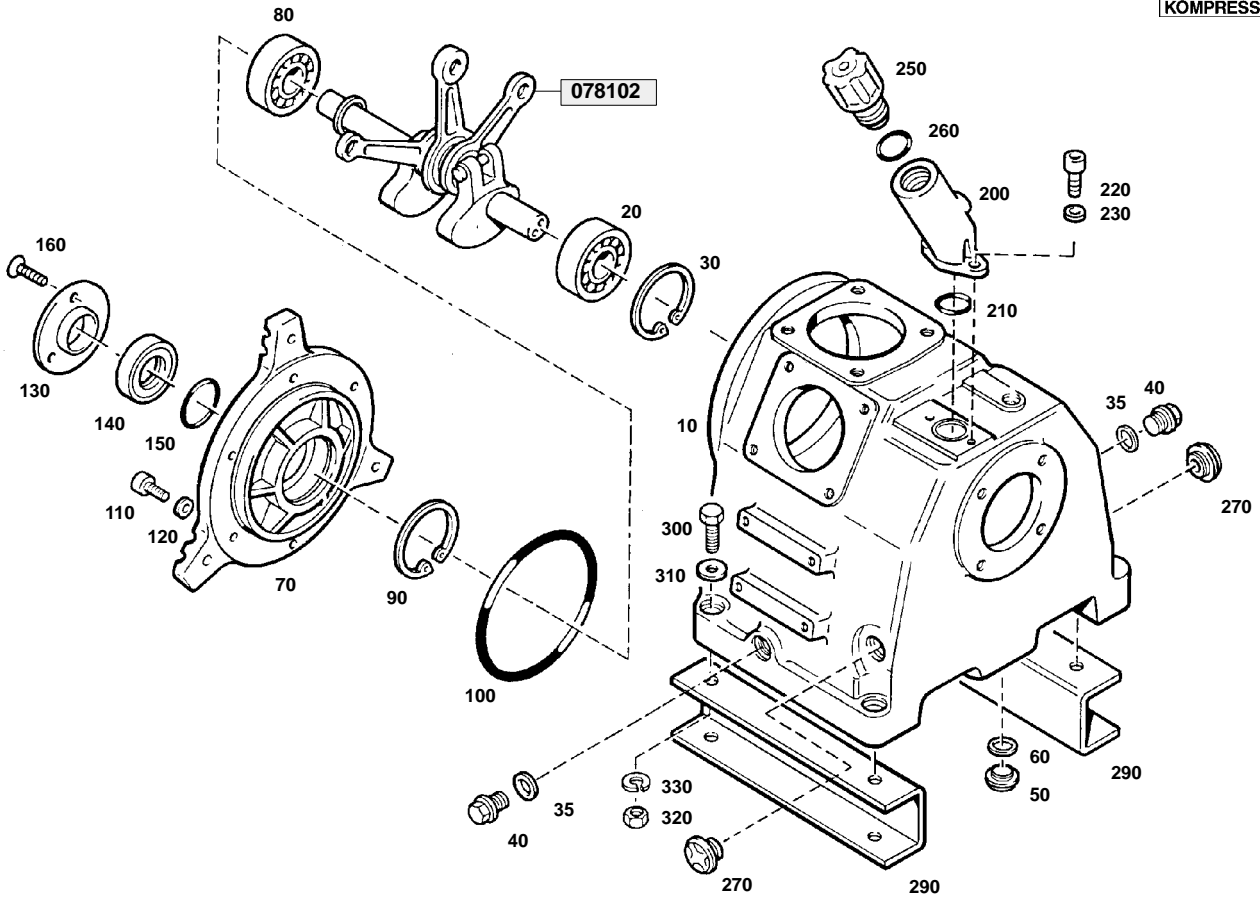

Wartungssätze
Maintenance sets
Kits d'entretien

Baugruppe 076743 Kurbelgehäuse, m. Zubehör, Triebwerk
 Assembly 076743 Crankcase with accessories, driving gear
 Assemblage 076743 Carter avec accessoires, embiellage

TM320-1

Klasse/ Class/ Classe			Pos.	Bestell-Nr. Part No. No. de cde.	Anz. Qty. Qté.	Benennung	Designation	Dénomination
a	b	c						
			320	N176	4	Federring	spring washer	rondelle-ressort
			330	N177	4	Sechskantmutter	hexagon nut	écrou hexagonal

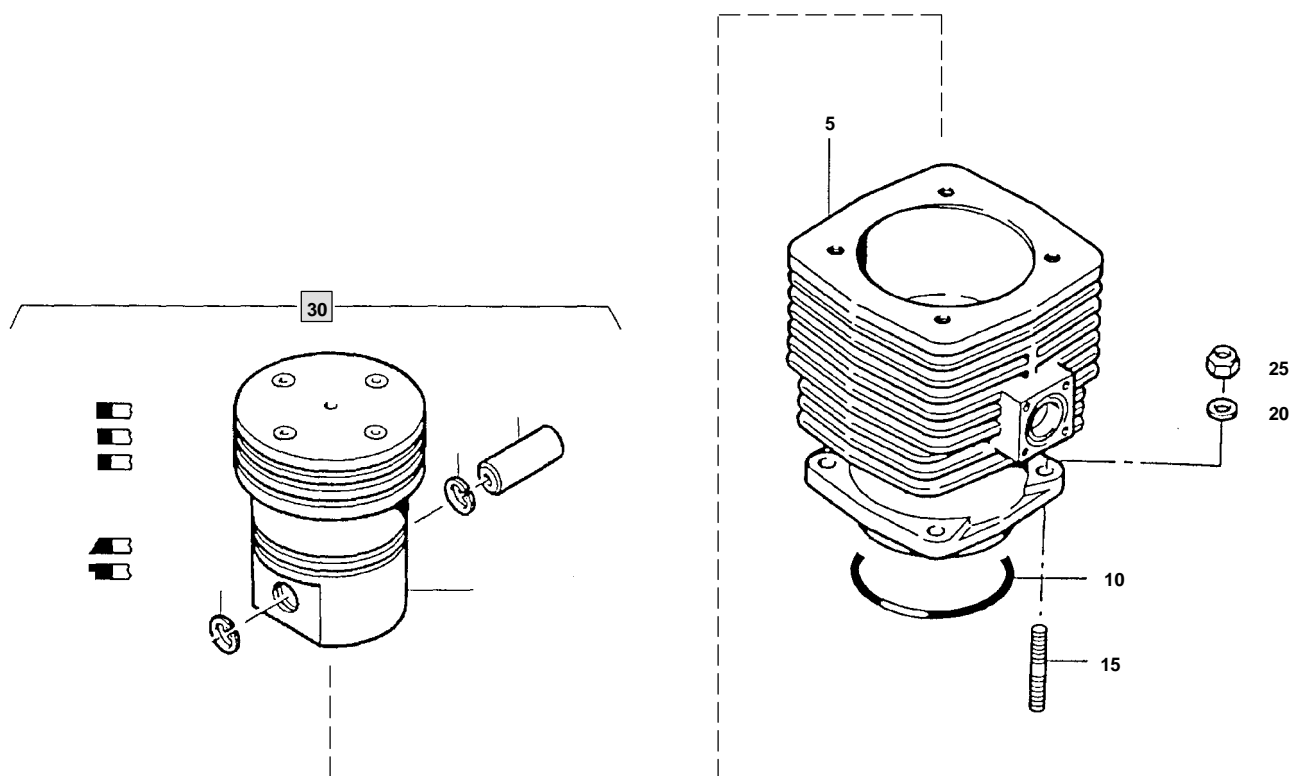
 Ersatzteilsätze
 Spare parts sets
 Kits de pièces dét.

Baugruppe 78110 **Zylinder 1./2. Stufe**
Assembly 78110 **Cylinder 1st/2nd stage**
Assemblage 78110 **Cylindre 1er/2e étage**
TM320-2

Klasse/ Class/ Classe			Pos.	Bestell-Nr. Part No. No. de cde.	Anz. Qty. Qté.	Benennung	Designation	Dénomination
a	b	c						
			5	77998	1	Stufenzylinder	stepped cylinder	cylindre étagé
		X	10	N4654	1	O-Ring	o-ring	joint torique
			15	N215	4	Stiftschraube	stud	goujon fileté
			20	N58	4	Scheibe	washer	rondelle
		X	25	N370	4	Selbstsichernde Mutter	hexagon nut self-locking	écrou hexagonal auto-frein.
			30	78095	1	Kolben kpl.	piston cpl.	piston cpl.

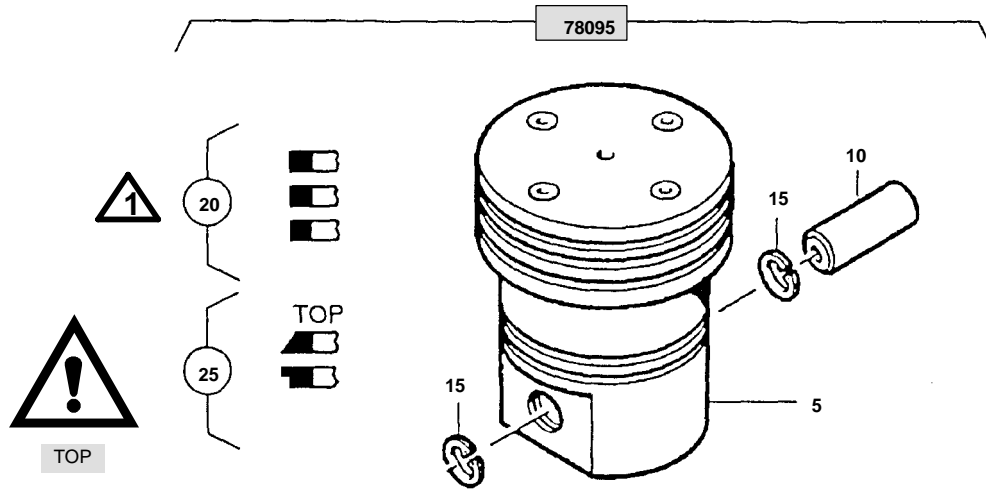

Ersatzteilsätze
Spare parts sets
Kits de pièces dét.

Baugruppe 78095
Assembly 78095
Assemblage 78095

Stufenkolben kpl.
Stepped piston cpl.
Piston étagé cpl.



ÄM 6528

TM320-2a

Klasse/ Class/ Classe			Pos.	Bestell-Nr. Part No. No. de cde.	Anz. Qty. Qté.	Benennung	Designation	Dénomination
a	b	c						
			5	78097	1	Stufenkolben	stepped piston	piston étagé
			10	N1216	1	Kolbenbolzen	piston pin	coussinet
			15	N484	2	Sicherungsring	circlip ring	rondelle de sûreté
			20	N25842	1	Kolbenringsatz	piston ring set	jeu des segments de piston
			25	N25396	1	Kolbenringsatz	piston ring set	jeu des segments de piston

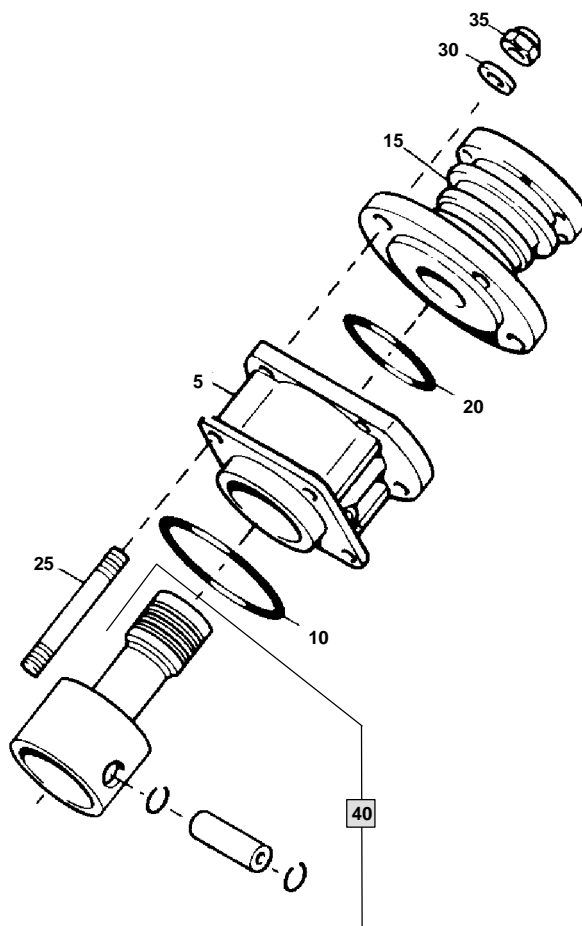
 Ersatzteilsätze
 Spare parts sets
 Kits de pièces dét.

Baugruppe 78335 **Zylinder 3. Stufe**
Assembly 78335 **Cylinder 3rd stage**
Assemblage 78335 **Cylindre 3e étage**
TM320-3

Klasse/ Class/ Classe			Pos.	Bestell-Nr. Part No. No. de cde.	Anz. Qty. Qté.	Benennung	Designation	Dénomination
a	b	c						
			5	66622	1	Führungszylinder	guide cylinder	cylindre de guidage
	X		10	N2640	1	O-Ring	o-ring	joint torique
			15	67940	1	Zylinder	cylinder	cylindre
	X		20	N7063	1	O-Ring	o-ring	joint torique
			25	N2790	4	Stiftschraube	stud	goujon fileté
			30	N58	4	Scheibe	washer	rondelle
	X		35	N370	4	Sechskantmutter	hexagon nut self-locking	écrou hexagonal auto-frein.
			40	78334	1	Kolben kpl.	piston cpl.	piston cpl.

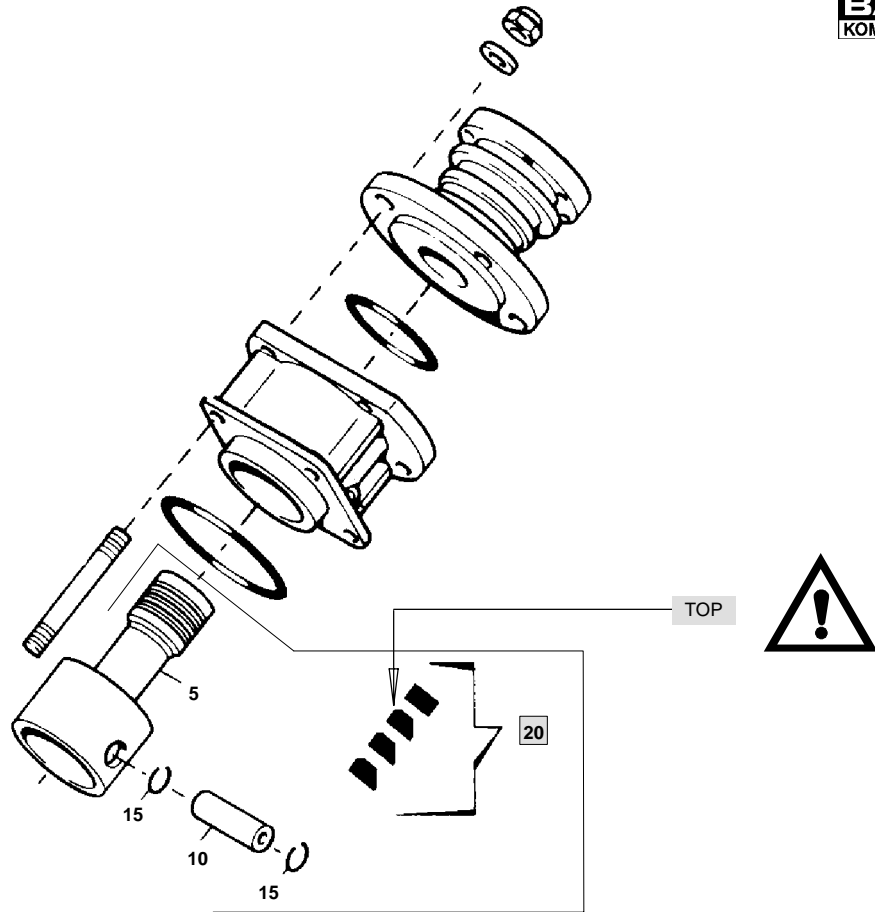

Ersatzteilsätze
Spare parts sets
Kits de pièces dét.

Baugruppe 78334 **Kolben kpl.**
Assembly 78334 **Piston cpl.**
Assemblage 78334 **Piston cpl.**

TM320-3a

Klasse/ Class/ Classe			Pos.	Bestell-Nr. Part No. No. de cde.	Anz. Qty. Qté.	Benennung	Designation	Dénomination
0	2	5						
			5	67942	1	Kolben	piston	piston
			10	N1429	1	Kolbenbolzen	piston pin	coussinet
			15	N484	2	Sicherungsring	circlip ring	rondelle de sûreté
			20	N19833	1	Kolbenringsatz	piston ring set	jeu de segments de piston

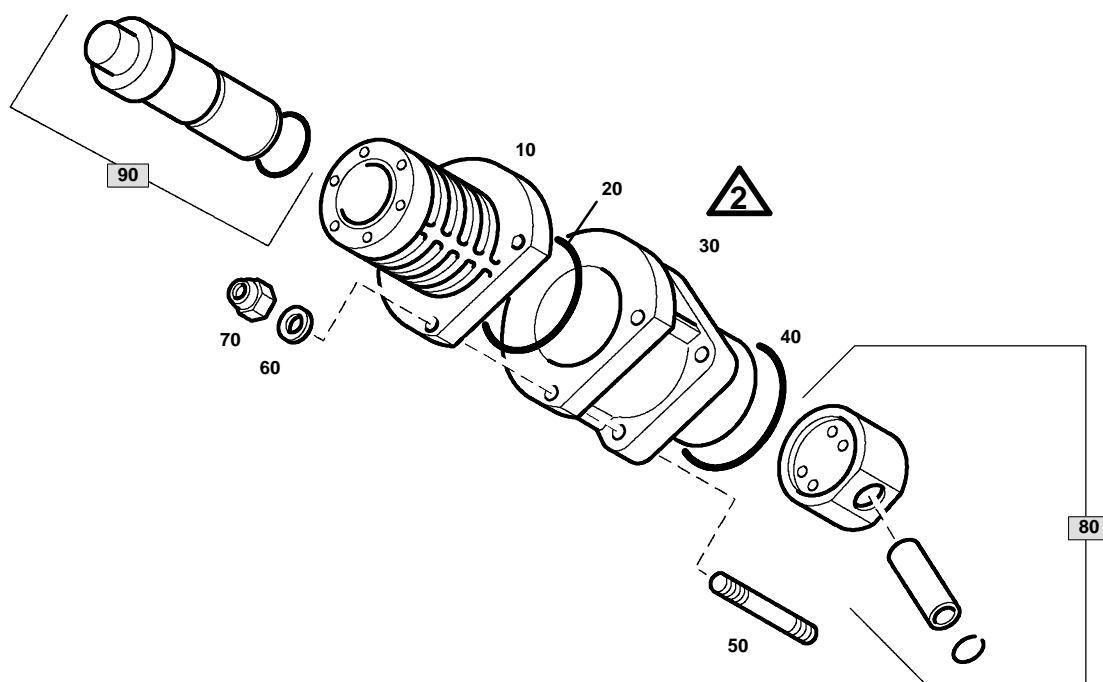
 Ersatzteilsätze
 Spare parts sets
 Kits de pièces dét.

Baugruppe	078044	Zylinder 4. Stufe
Assembly	078044	Cylinder 4th stage
Assemblage	078044	Cylindre 4e étage

TM320-4

Klasse/ Class/ Classe			Pos.	Bestell-Nr. Part No. No. de cde.	Anz. Qty. Qté.	Benennung	Designation	Dénomination
a	b	c						
			10	76754	1	Zylinder	cylinder	cylindre
		X	20	N7063	1	O-Ring	o-ring	joint torique
			30	80381	1	Führungszylinder	guide cylinder	cylindre de guidage
		X	40	N2640	1	O-Ring	o-ring	joint torique
			50	N2790	4	Stiftschraube	stud	goujon fileté
			60	N58	4	Scheibe	washer	rondelle
		X	70	N370	4	Sechskantmutter	hexagon nut self-locking	écrou hexagonal auto-frein.
			80	072165	1	Kolben kpl.	piston cpl.	piston cpl.
			90	078045	1	Kolbenbüchse kpl.	sleeve	douille

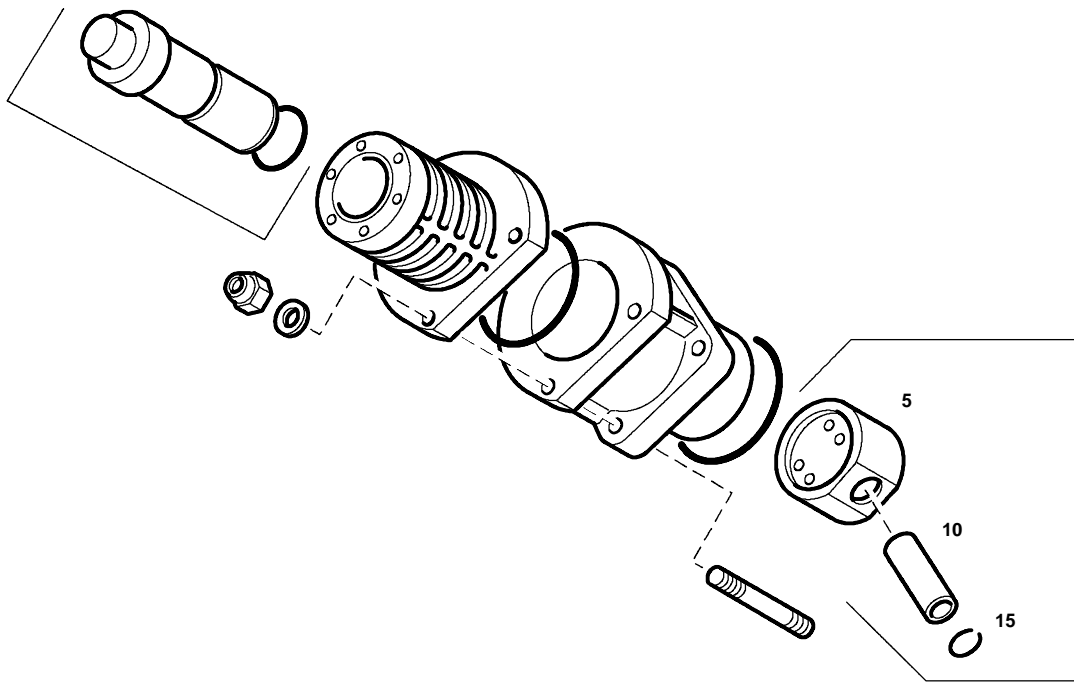

Ersatzteilsätze
Spare parts sets
Kits de pièces dét.

Baugruppe 072165 **Kolben kpl.**
Assembly 072165 **Piston assy.**
Assemblage 072165 **Piston cpl.**

TM320-4a

Klasse/ Class/ Classe			Pos.	Bestell-Nr. Part No. No. de cde.	Anz. Qty. Qté.	Benennung	Designation	Dénomination
0	2	5						
			5	N858	1	Führungskolben	guide piston	piston guide
			10	N1429	1	Kolbenbolzen	piston pin	coussinet
			15	N484	2	Sicherungsring	circlip ring	rondelle de sûreté

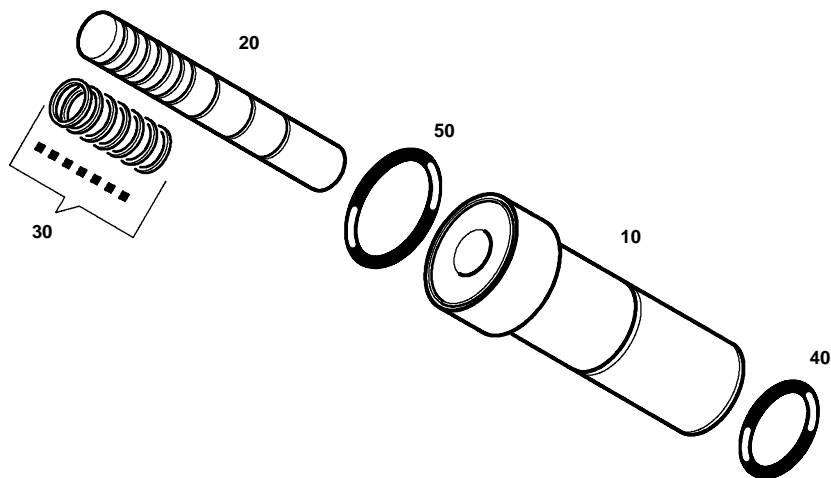
 Ersatzteilsätze
 Spare parts sets
 Kits de pièces dét.

Baugruppe 078045
Assembly 078045
Assemblage 078045

Kolbenbüchse kpl.
Piston and sleeve
Douille de piston
TM320-4b

Klasse/ Class/ Classe			Pos.	Bestell-Nr. Part No. No. de cde.	Anz. Qty. Qté.	Benennung	Designation	Dénomination
a	b	c						
			10	*	1	Kolbenbüchse	piston liner	douille de piston
			20	*	1	Kolben	piston	piston
			30	*	1	Kolbenringsatz	piston ring set	jeu des segments
		X	40	N2320	1	O-Ring	o-ring	joint torique
X			50	N23755	1	O-Ring	o-ring	joint torique

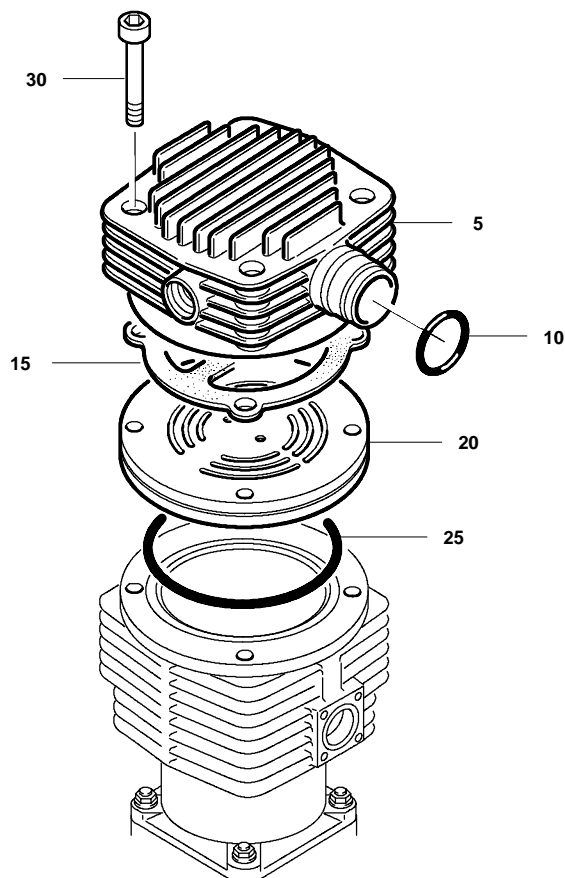

Ersatzteilsätze
 Spare parts sets
 Kits de pièces dét.

Baugruppe 073429 **Ventilkopf 1. Stufe**
Assembly 073429 **Valve head 1st stage**
Assemblage 073429 **Culasse 1er étage**

TM320-5

Klasse/ Class/ Classe			Pos.	Bestell-Nr. Part No. No. de cde.	Anz. Qty. Qté.	Benennung	Designation	Dénomination
a	b	c						
			5	67936	1	Ventilkopf	valve head	culasse
			10	N1539	1	O-Ring	o-ring	joint torique
X			15	67979	1	Zylinder-Dichtung	gasket	joint
	X		20	N17950	1	Lamellenventil	reed valve	soupape à lamelles
X			25	N17959	1	O-Ring	o-ring	joint torique
			30	N354	4	Zylinderschraube	allen screw	vis à six pans creux

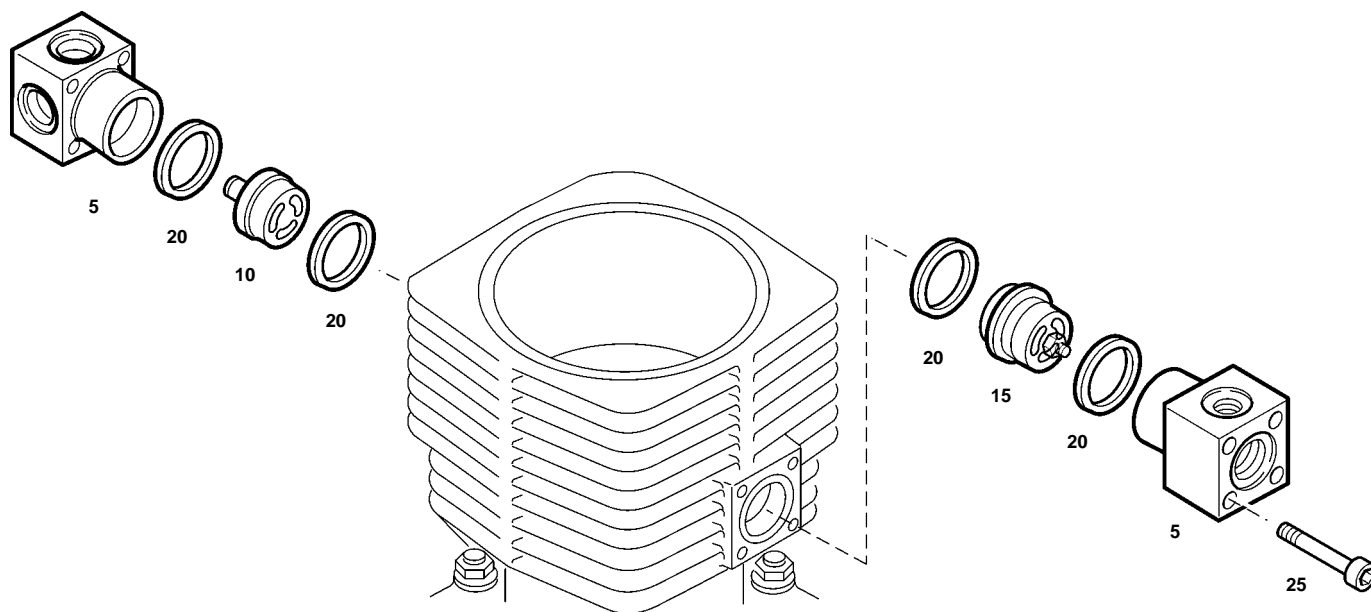
 Ersatzteilsätze
 Spare parts sets
 Kits de pièces dét.

Baugruppe 073435 **Ventilkopf 2. Stufe**
Assembly 073435 **Valve head 2nd stage**
Assemblage 073435 **Culasse 2e étage**
TM320-6

Klasse/ Class/ Classe			Pos.	Bestell-Nr. Part No. No. de cde.	Anz. Qty. Qté.	Benennung	Designation	Dénomination
a	b	c						
			5	78562	2	Saug- und Druckstutzen	intake and pressure coupling	raccord d'aspiration et de compression
	X		10	N4067	1	Saugventil kpl.	intake valve	soupape d'aspiration
	X		15	N4068	1	Druckventil kpl.	pressure valve	soupape de compression
X			20	56668	4	Dichtring	gasket	joint
			25	N724	8	Zylinderschraube	allen screw	vis à six pans creux

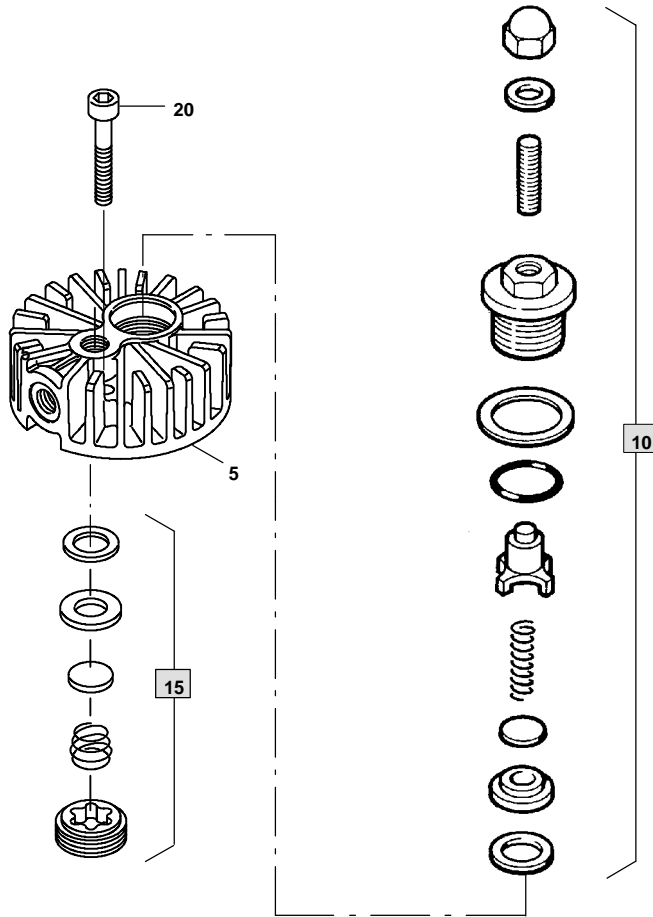

Ersatzteilsätze
Spare parts sets
Kits de pièces dét.

Baugruppe 069792 **Ventilkopf 3. Stufe**
Assembly 069792 **Valve head 3rd stage**
Assemblage 069792 **Culasse 3e étage**

TM320-7

Klasse/ Class/ Classe			Pos.	Bestell-Nr. Part No. No. de cde.	Anz. Qty. Qté.	Benennung	Designation	Dénomination
a	b	c						
			5	14123	1	Ventilkopf	valve head	culasse
			10	014582	1	Druckventil kpl.	pressure valve	soupape de compression
	X		15	012836	1	Saugventil	suction valve	soupape d'aspiration
			20	N503	6	Zylinderschraube	allen screw	vis à six pans creux

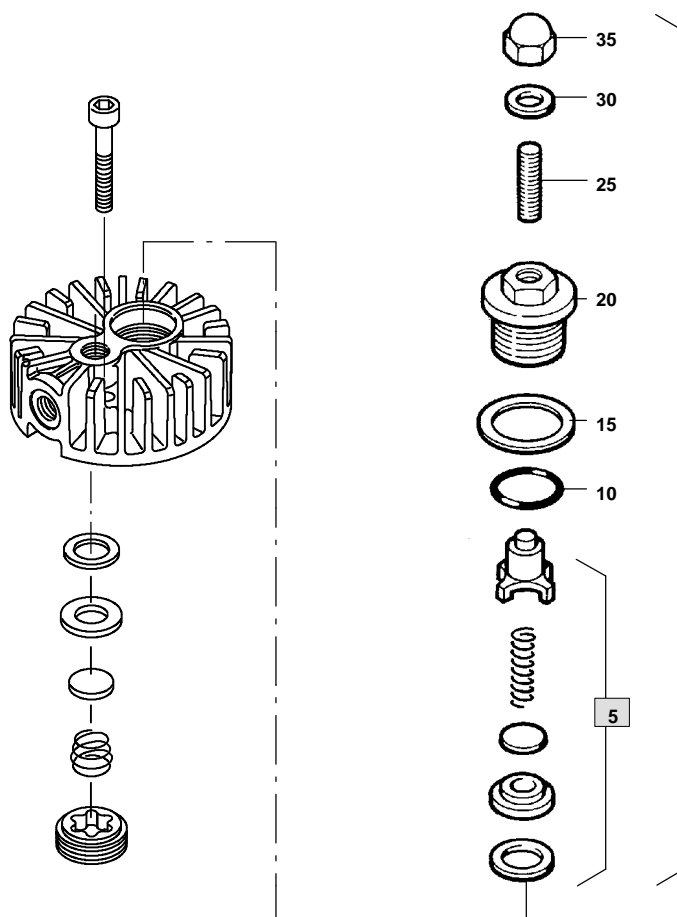
 Ersatzteilsätze
 Spare parts sets
 Kits de pièces dét.

Baugruppe 014582
Assembly 014582
Assemblage 014582

Druckventil kpl.
Pressure valve
Soupape de compression
TM320-7a

Klasse/ Class/ Classe			Pos.	Bestell-Nr. Part No. No. de cde.	Anz. Qty. Qté.	Benennung	Designation	Dénomination
a	b	c						
	X		5	012835	1	Druckventileinsatz kpl.	pressure valve insert	soupape de compression
X			10	N3521	1	O-Ring	o-ring	joint torique
			15	14332	1	Tellerfeder	spring washer	rondelle-ressort
			20	14124	1	Verschraubung	coupling	raccord
	X		25	71064	1	Gewindestift	stud	goujon fileté
X			30	N380	1	Dichtung	gasket	joint
			35	N84	1	Sechskant-Hutmutter	acorn nut	écrou borgne

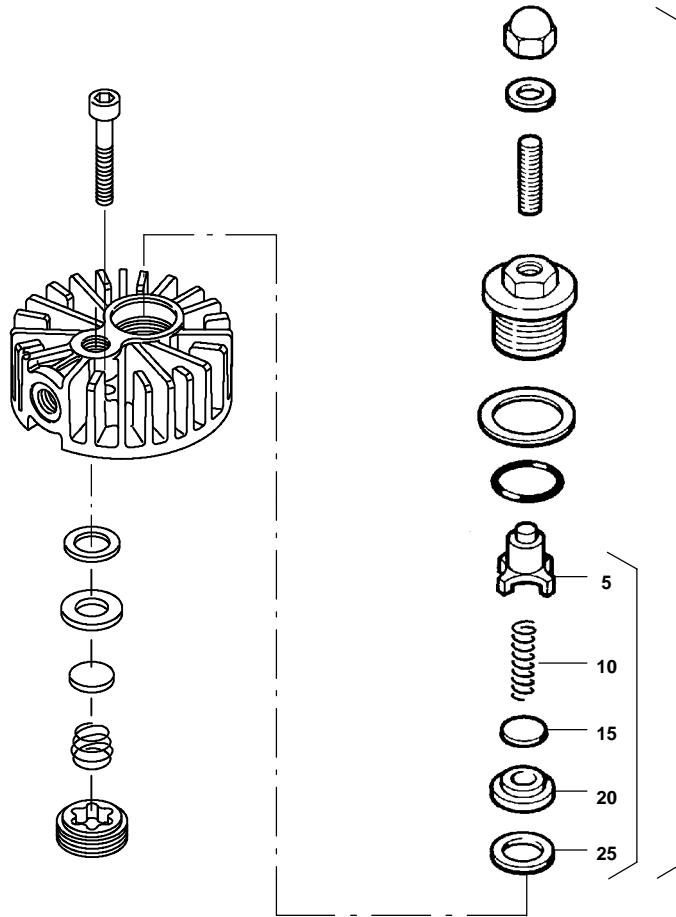

Ersatzteilsätze
Spare parts sets
Kits de pièces dét.

Baugruppe 012835 **Druckventileinsatz kpl.**
Assembly 012835 **Pressure valve insert**
Assemblage 012835 **Soupape de compression**

TM320-7b

Klasse/ Class/ Classe			Pos.	Bestell-Nr. Part No. No. de cde.	Anz. Qty. Qté.	Benennung	Designation	Dénomination
a	b	c						
			5		1	Druckventileinsatz	pressure valve insert	soupape de compression
			10	1026	1	Ventilfeder	valve spring	ressort de soupape
			15		1	Ventilplatte	valve plate	plaque de soupape
			20		1	Ventilsitz	valve seat	siège de soupape
X			25	240	1	Dichtung	gasket	joint

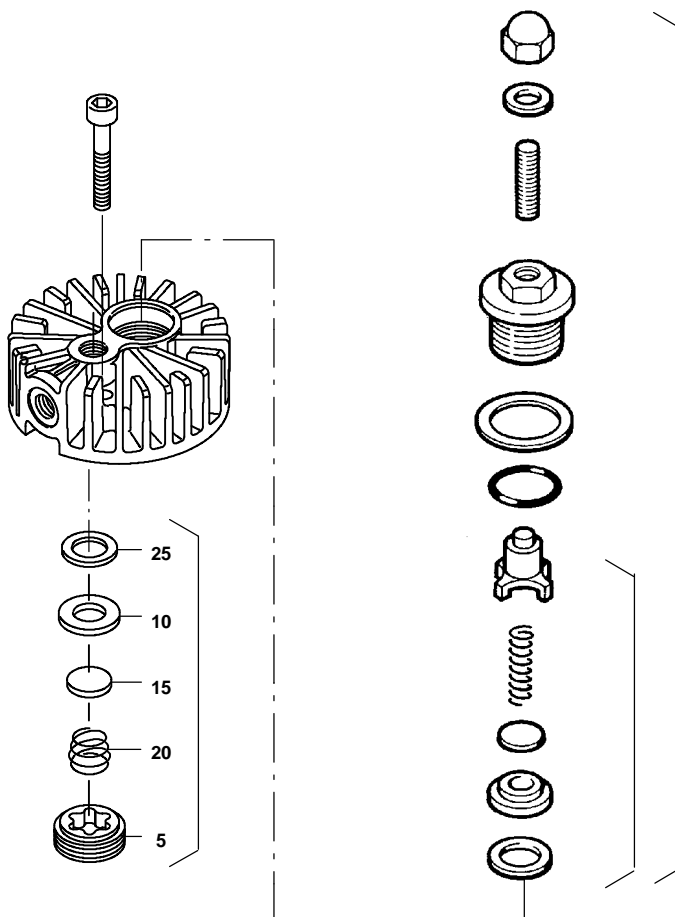

Ersatzteilsätze
 Spare parts sets
 Kits de pièces dét.

Baugruppe 012836
Assembly 012836
Assemblage 012836

Saugventil
Suction valve
Soupape d'aspiration

TM320-7c

Klasse/ Class/ Classe			Pos.	Bestell-Nr. Part No. No. de cde.	Anz. Qty. Qté.	Benennung	Designation	Dénomination
a	b	c						
			5		1	Ventilverschraubung	valve screwing	filetage de soupape
			10		1	Ventilsitz	valve seat	siège de soupape
			15		1	Ventilplatte	valve plate	plaque de soupape
			20		1	Druckfeder	pressure spring	ressort de pression
X			25	240	1	Dichtung	gasket	joint

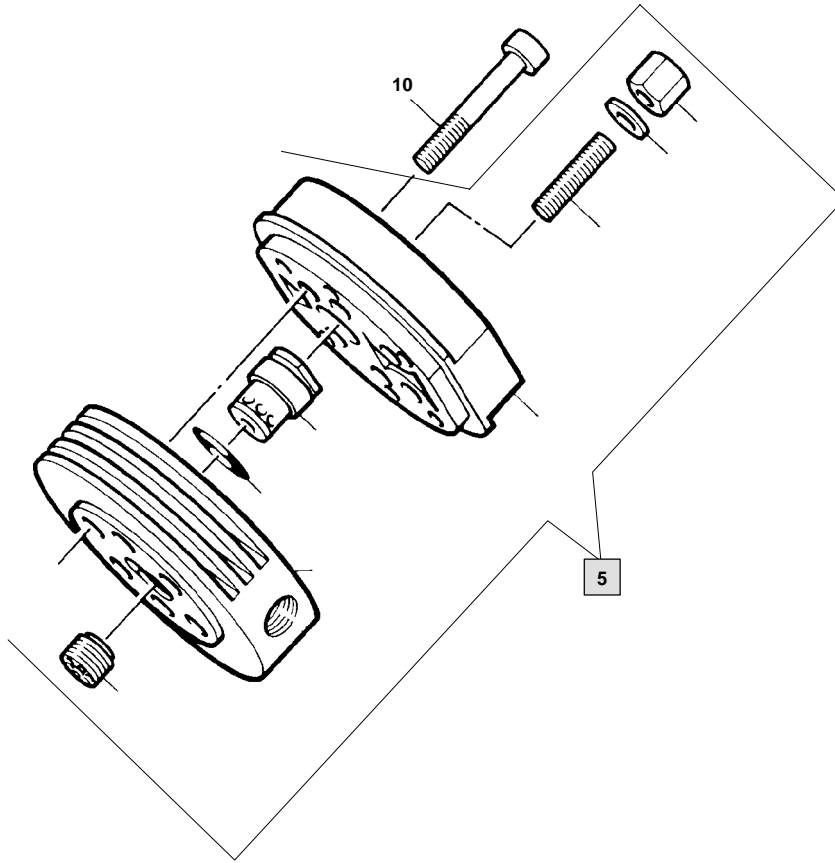

068607/12/948



Wartungssätze
Maintenance sets
Kits d'entretien

Baugruppe 068607 **Ventilkopf**
Assembly 068607 **Valve head**
Assemblage 068607 **Culasse**

TM320-8

Klasse/ Class/ Classe			Pos.	Bestell-Nr. Part No. No. de cde.	Anz/ Qty/ Qté	Benennung	Designation	Dénomination
a	b	c						
			5	073629	1	Ventilkopf	valve head	culasse
			10	N1282	6	Zylinderschraube	allen screw	vis à six pans creux

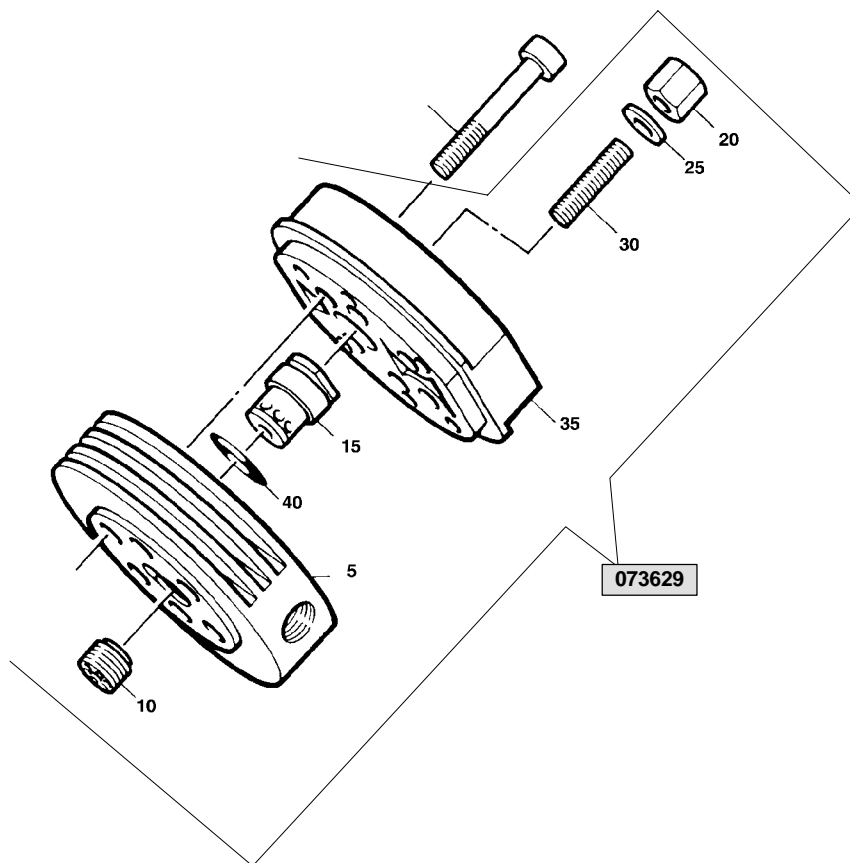

073629/12/98

 Wartungssätze
 Maintenance sets
 Kits d'entretien

Baugruppe 073629
Assembly 073629
Assemblage 073629

Ventilkopf
Valve head
Culasse
TM320-8a

Klasse/ Class/ Classe			Pos.	Bestell-Nr. Part No. No. de cde.	Anz/ Qty/ Qté	Benennung	Designation	Dénomination
a	b	c						
			5	65191	1	Ventilkopf	valve head	culasse
	X		10	07790	1	Saugventil	suction valve	clapet d'aspiration
	X		15	014121	1	Druckventil	pressure valve	soupape de pression
			20	N3623	1	Sechskant-Hutmutter	acorn nut	écrou borgne
X			25	N3625	1	Dichtring	gasket	joint
	X		30	71065	1	Gewindestift	stud	goujon fileté
			35	14118	1	Ventilkopf-Deckel	valve head cover	couvercle de culasse
			40	N2789	1	O-Ring	o-ring	joint torique

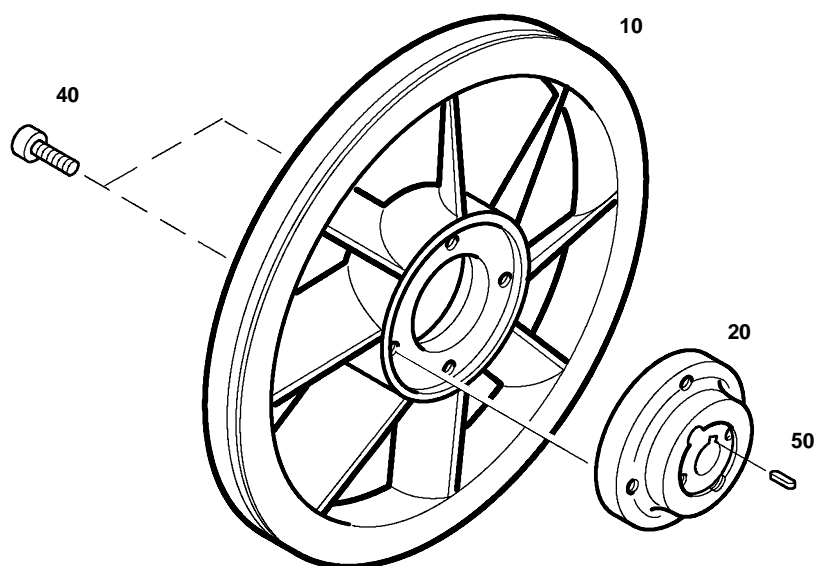
 Wartungssätze
 Maintenance sets
 Kits d'entretien

Baugruppe 076251 **Schwungrad**
Assembly 076251 **Flywheel**
Assemblage 076251 **Volant-ventilateur**
TM320-9

Klasse/ Class/ Classe			Pos.	Bestell-Nr. Part No. No. de cde.	Anz. Qty. Qté.	Benennung	Designation	Dénomination
a	b	c						
			10	76217	1	Ventilatorrad	fanwheel	ventilateur
			20	76211	1	Ventilatorradnabe	fanwheel hub	moyeu de ventilateur
			40	N61	4	Zylinderschraube	allen screw	vis à six pans creux
			50	N1386	1	Paßfeder	feather key	ressort d'ajustage

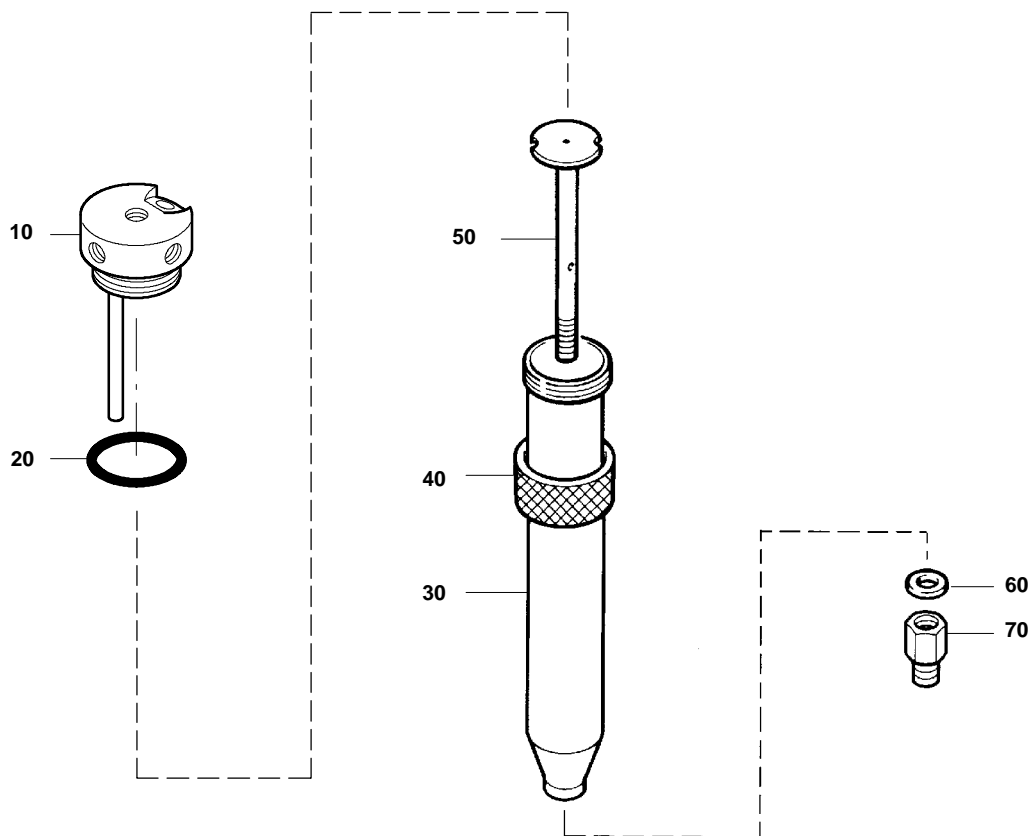

80690/07/02

 Wartungssätze
 Maintenance sets
 Kits de maintenance

Baugruppe 80690
Assembly 80690
Assemblage 80690

Zwischenabscheider
Intermediate separator
Séparateur intermédiaire
TM320-10

Klasse/ Class/ Classe			Pos.	Bestell-Nr. Part No. No. de cde.	Anz. Qty. Qté.	Benennung	Designation	Dénomination
a	b	c						
			10	80691*	1	Filterkopf kpl.	filter head assy.	Culasse
X			20	N3556	1	O-Ring	o-ring	joint torique
			30	14150*	1	Behältergehäuse	filter housing	corps de filtre
			40	13937	1	Überwurfmutter	screw cap	écrou borgne
			50	76613	1	Einschraubteil kpl.	screw in part assy.	manchon visse
			60	N1316	1	Dichtring	gasket	joint
			70	N20215	1	G-Aufschraubstutzen	straight connector	raccord droit mâle

*

nur zusammen lieferbar

only available together

Ne sont livrées qu'ensemble

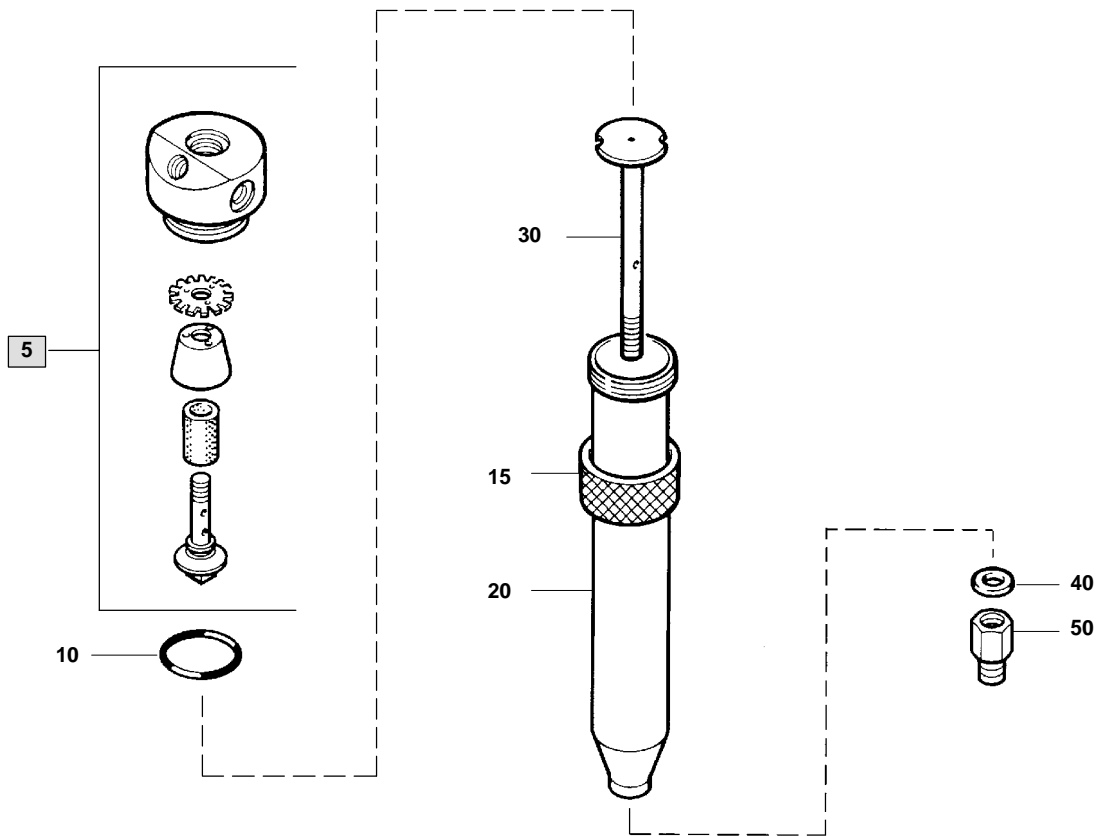

78189/02/00

 Wartungssätze
 Maintenance sets
 Kits de maintenance

Baugruppe	78189	Zwischenabscheider
Assembly	78189	Intermediate separator
Assemblage	78189	Séparateur intermédiaire

TM320-11

Klasse/ Class/ Classe			Pos.	Bestell-Nr. Part No. No. de cde.	Anz. Qty. Qté.	Benennung	Designation	Dénomination
a	b	c						
			5	*	1	Filterkopf kpl.	filter head assy.	tête de filtre cpl.
X			10	N3556	1	O-Ring	o-ring	joint torique
			15	13937	1	Überwurfmutter	screw cap	écrou borgne
			20	*	1	Behältergehäuse	filter housing	corps de filtre
			30	76613	1	Einschraubteil kpl.	screw in part assy.	manchon fileté
			40	N1316	1	Dichtring	gasket	joint
			50	N20215	1	G-Aufschraubstutzen	straight connector	raccord droit mâle

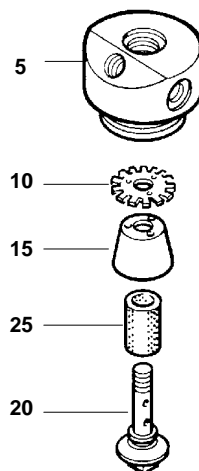

78189/02/00

 Wartungssätze
 Maintenance sets
 Kits de maintenance

Baugruppe 78188
Assembly 78188
Assemblage 78188

Filterkopf kpl.
Filter head assy.
Tête de filtre cpl.
TM320-11a

Klasse/ Class/ Classe			Pos.	Bestell-Nr. Part No. No. de cde.	Anz. Qty. Qté.	Benennung	Designation	Dénomination
a	b	c						
			5		1	Filterkopf	filter head	tête de filtre
			10	12784	1	Verteilerblech	distribution plate	plaque de dispersion
			15	12785	1	Pralltrichter	baffle funnel	cône
			20	12786	1	Schraube	center screw	vis centrale
X			25	N2726	1	Filtereinsatz	filter insert	élément filtrant

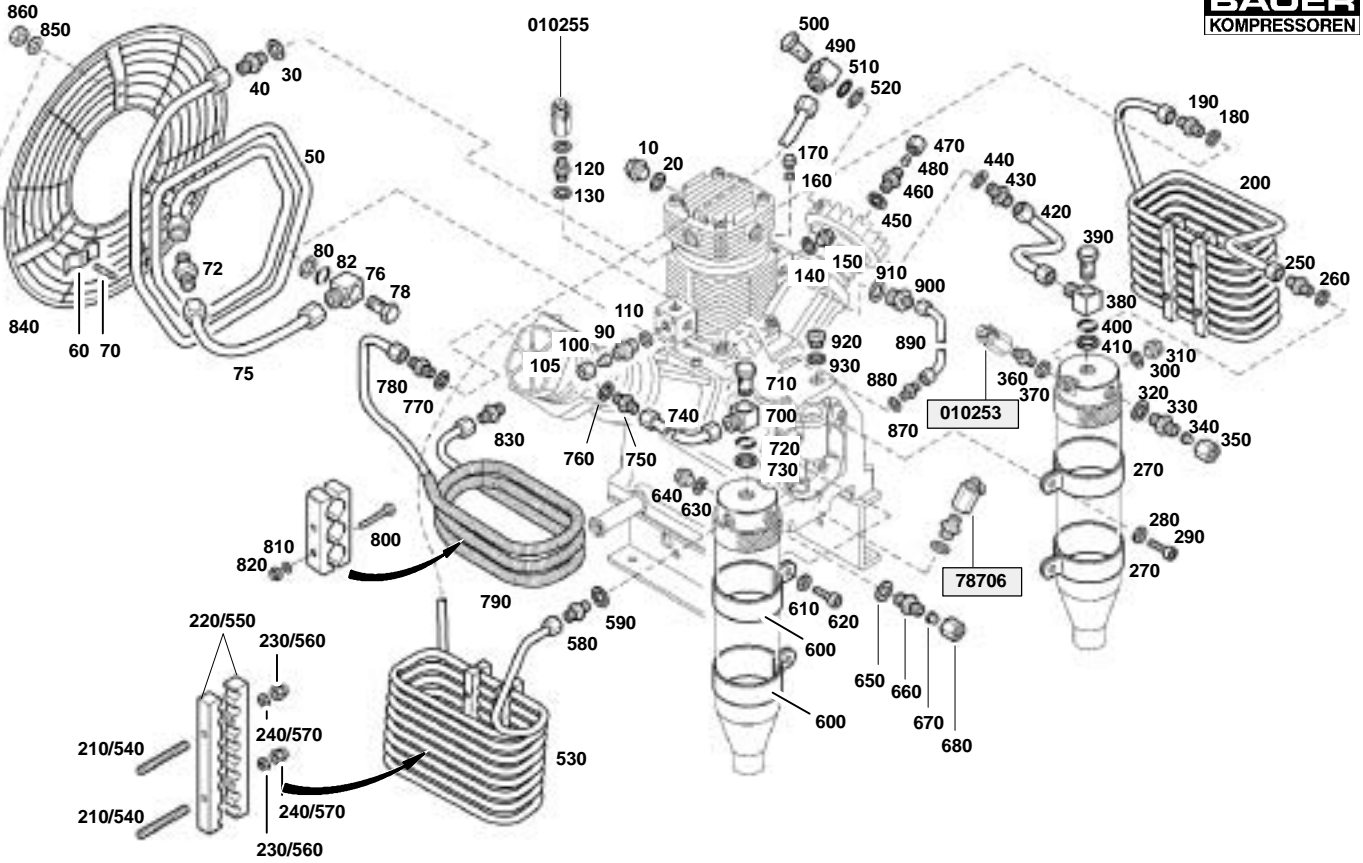

80698/07/02



Ersatzteilsätze
Spare parts sets
Kits de pièces dét.

Baugruppe 80698
Assembly 80698
Assemblage 80698

Kühlung
Cooling system
Refroidissement

TM320-12

Klasse/ Class/ Classe			Pos.	Bestell-Nr. Part No. No. de cde.	Anz. Qty. Qté.	Benennung	Designation	Dénomination
a	b	c						
			10	N204	1	Verschlußschraube	plug	bouchon fileté
			20	N842	1	Dichtring	gasket	joint
			30	N293	1	Dichtring	gasket	joint
			40	N20231	1	G-Einschraubstutzen	straight male connector	raccord droit mâle
			50	78295	1	Zwischenkühler kpl.	inter cooler assy.	refroid. intermédiaire cpl.
			60	11887	3	Schelle	double strap	collier double
			70	78199	3	Gewindestift	headless screw	vis sans tête
			72	N20202	1	G-Reduzierstutzen	straight reducer connector	raccord droit réducteur
			75	78584	1	Verbindungsleitung	connecting tube	tuyau de connexion
			76	N25449	1	Schwenkstutzen	connector	raccord
			78	N25450	1	Hohlschraube	hollow screw	raccord
			80	N25451	1	Dichtring kpl.	gasket	joint
			82	N25452	1	O-Ring	o-ring	joint torique
			90	N20195	1	G-Einschraubstutzen	straight male connector	raccord droit mâle
			100	N4530	1	Verschlußstopfen	plug	bouchon
			105	N3610	1	Überwurfmutter	screw cap	écrou borgne
			110	N1316	1	Dichtring	gasket	joint
			120	N20201	1	G-Einschraubstutzen	straight male connector	raccord droit mâle
			130	N1316	1	Dichtring	gasket	joint
			140	N1316	1	Dichtring	gasket	joint
			150	N52	1	Verschlußschraube	plug	bouchon fileté
			160	N293	1	Dichtring	gasket	joint
			170	N314	1	Verschlußschraube	plug	bouchon fileté
			180	N1316	1	Dichtring	gasket	joint
			190	N20059	1	G-Einschraubstutzen	straight male connector	raccord
			200	80696	1	Zwischenkühler kpl.	inter cooler assy.	refroid. intermédiaire cpl.
			210	N3494	4	Stiftschraube	stud	goujon fileté

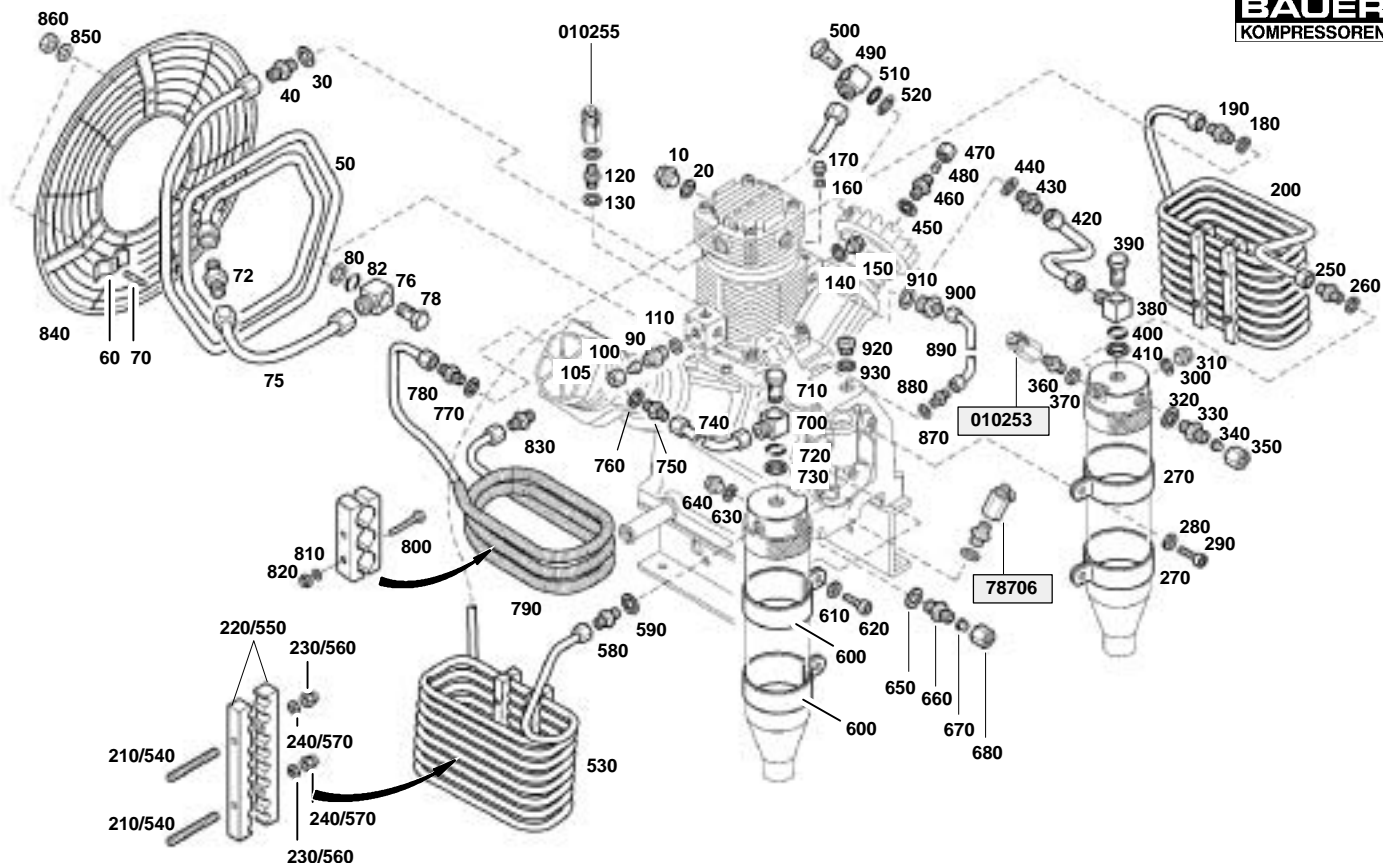

80698/07/02



 Ersatzteilsätze
 Spare parts sets
 Kits de pièces dét.

 Baugruppe 80698
 Assembly 80698
 Assemblage 80698

 Kühlung
 Cooling system
 Refroidissement

TM320-12

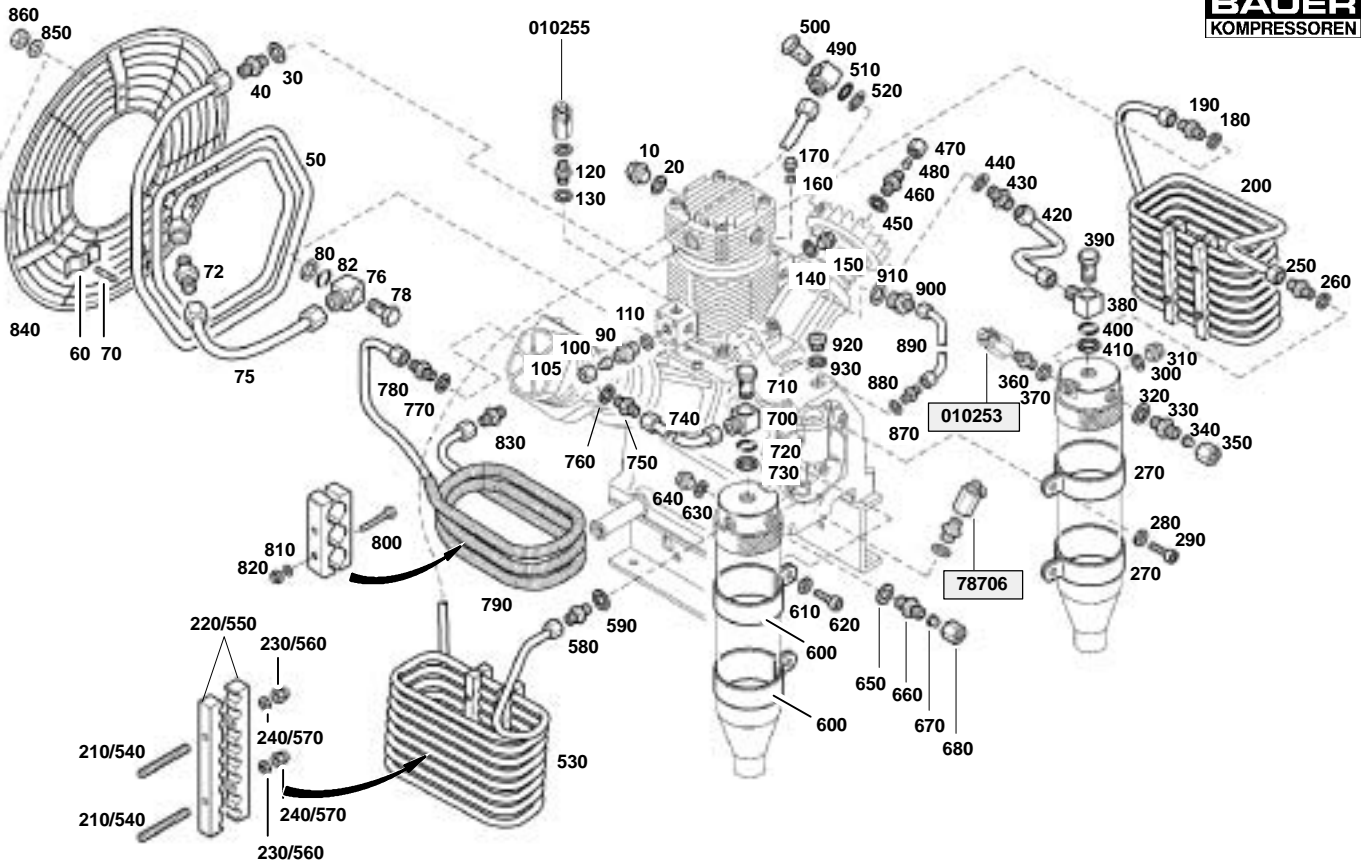
Klasse/ Class/ Classe			Pos.	Bestell-Nr. Part No. No. de cde.	Anz. Qty. Qté.	Benennung	Designation	Dénomination
a	b	c						
			220	62773	4	Fixierung	fixing for cooler	fixation de refroidisseur
			230	N102	4	Scheibe	washer	rondelle
			240	N1042	4	Sechskantmutter	hexagon nut self-locking	écrou hexagonal auto-frein.
			250	N20059	1	G-Einschraubstutzen	straight male connector	raccord droit mâle
			260	N1316	1	Dichtring	gasket	joint
			270	77894	2	Rohrschelle	clamp	collier
			280	N2460	2	Scheibe	washer	rondelle
			290	N88	2	Sechskantschraube	hexagon screw	vis hexagonale
			300	N1316	1	Dichtring	gasket	joint
			310	N52	1	Verschlusschraube	plug	bouchon fileté
			320	N1316	1	Dichtring	gasket	joint
			330	N20195	1	G-Einschraubstutzen	straight male connector	raccord droit mâle
			340	N4530	1	Verschlussstopfen	plug	bouchon
			350	N3610	1	Überwurfmutter	screw cap 6S	écrou borgne
			360	N20197	1	G-Einschraubstutzen	straight male connector	raccord droit mâle
			370	4479	1	Dichtring	gasket	joint
			380	N25449	1	Schwenkstutzen	connector	raccord
			390	N25450	1	Hohlschraube	hollow screw	vis creuse
			400	N25452	1	O-Ring	o-ring	joint torique
			410	N25451	1	Dichtring kpl.	gasket	joint
			420	78300	1	Verbindungsleitung kpl.	connecting tube assy.	tuyau de connexion cpl.
			430	N20059	1	G-Einschraubstutzen	straight male connector	raccord droit mâle
			440	N1316	1	Dichtring	gasket	joint
			450	N1316	1	Dichtring	gasket	joint
			460	N20195	1	G-Einschraubstutzen	straight male connector	raccord droit mâle
			470	N4530	1	Verschlussstopfen	plug	bouchon
			480	N3610	1	Überwurfmutter	screw cap 6S	écrou borgne



80698/07/02



Ersatzteilsätze
Spare parts sets
Kits de pièces dét.

Baugruppe 80698
Assembly 80698
Assemblage 80698

Kühlung
Cooling system
Refrroidissement

TM320-12

Klasse/ Class/ Classe			Pos.	Bestell-Nr. Part No. No. de cde.	Anz. Qty. Qté.	Benennung	Designation	Dénomination
a	b	c						
			490	N25449	1	Schwenkstutzen	connector	raccord
			500	N25450	1	Hohlschraube	hollow screw	vis creuse
			510	N25452	1	O-Ring	o-ring	joint torique
			520	N25451	1	Dichtring kpl.	gasket	joint
			530	78195	1	Zwischenkühler kpl.	inter cooler assy.	refroid. intermédiaire cpl.
			540	N3494	4	Stiftschraube	stud	goujon fileté
			550	62773	4	Fixierung	fixing for cooler	fixation de refroidisseur
			560	N102	4	Scheibe	washer	rondelle
			570	N1042	4	Sechskantmutter	hexagon nut self-locking	écrou hexagonal auto-frein.
			580	N20059	1	G-Einschraubstutzen	straight male connector	raccord droit mâle
			590	N1316	1	Dichtring	gasket	joint
			600	77894	2	Rohrschelle	clamp	collier
			610	N2460	2	Scheibe	washer	rondelle
			620	N88	2	Sechskantschraube	hexagon screw	vis hexagonale
			630	N1316	1	Dichtring	gasket	joint
			640	N52	1	Verschlußschraube	plug	bouchon fileté
			650	N1316	1	Dichtring	gasket	joint
			660	N20195	1	G-Einschraubstutzen	straight male connector	raccord droit mâle
			670	N4530	1	Verschlußstopfen	plug	bouchon
			680	N3610	1	Überwurfmutter	screw cap 6S	écrou borgne
			700	N25449	1	Schwenkstutzen	connector	raccord
			710	N25450	1	Hohlschraube	hollow screw	vis creuse
			720	N25452	1	O-Ring	o-ring	joint torique
			730	N25451	1	Dichtring kpl.	gasket	joint
			740	78197	1	Verbindungsleitung kpl.	connecting tube assy.	tuyau de connexion cpl.
			750	N20059	1	G-Einschraubstutzen	straight male connector	raccord droit mâle
			760	N1316	1	Dichtring	gasket	joint

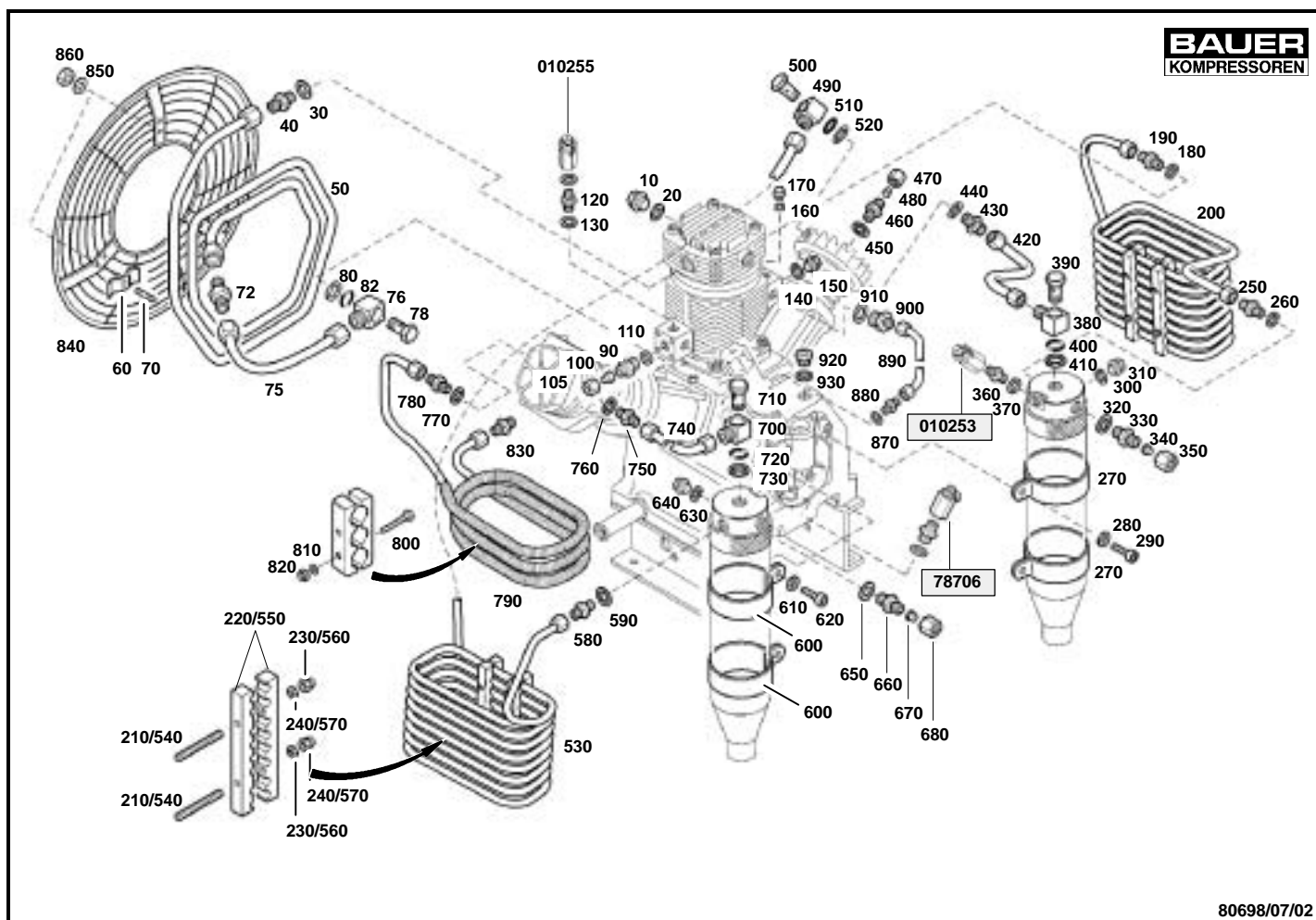

80698/07/02



 Ersatzteilsätze
 Spare parts sets
 Kits de pièces dét.

 Baugruppe 80698
 Assembly 80698
 Assemblage 80698

 Kühlung
 Cooling system
 Refroidissement

TM320-12

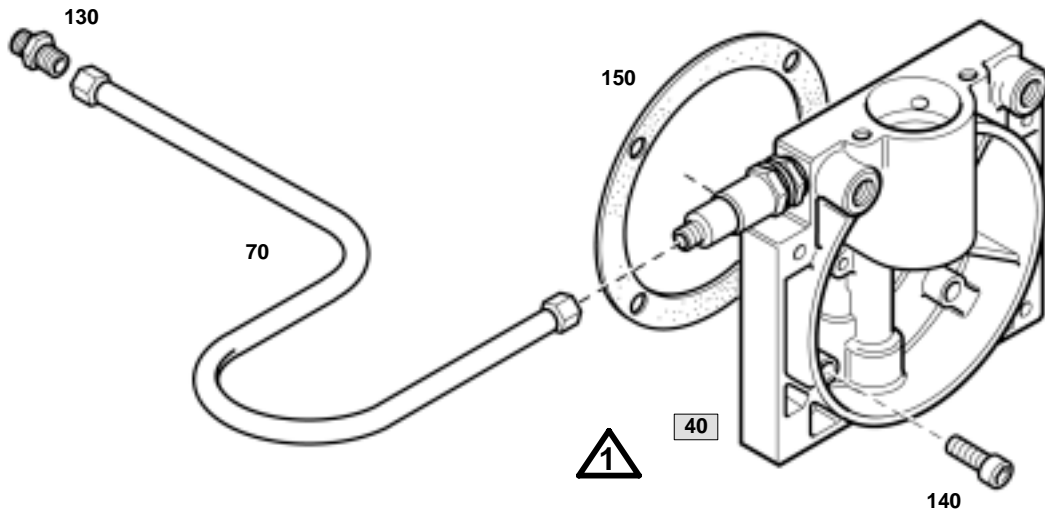
Klasse/ Class/ Classe			Pos.	Bestell-Nr. Part No. No. de cde.	Anz. Qty. Qté.	Benennung	Designation	Dénomination
a	b	c						
			770	56983	1	Dichtring	gasket	joint
			780	71148	1	Rohrverschraubung	connector	raccord
			790	78301	1	Nachkühler kpl.	after cooler assy.	refroidisseur final cpl.
			800	N3498	4	Sechskantschraube	hex. srew	écrou 6 pans
			810	N3313	4	Scheibe	washer	rondelle
			820	N1042	4	Sechskantmutter	hexagon nut self-locking	écrou hexagonal auto-frein.
			830	N20208	1	G-Stutzen	straight male connector	raccord droit mâle
			840	78200	1	Lüfterradchutz	fanwheel protector	protection de ventilateur
			850	N58	3	Scheibe	washer	rondelle
			860	N370	3	Sechskantmutter	hexagon nut self-locking	écrou hexagonal auto-frein.
			870	N1316	1	Dichtring	gasket	joint
			880	N20014	1	G-Einschraubstutzen	straight male connector	raccord droit mâle
			890	78303	1	Verbindungsleitung kpl.	connecting tube	tuyau
			900	N20188	1	G-Einschraubstutzen	straight male connector	raccord droit mâle
			910	N842	1	Dichtring	gasket	joint
			920	N314	1	Verschlusschraube	plug	bouchon
			930	N293	1	Dichtring	gasket	joint



078039/12/01



Wartungssätze
Maintenance sets
Kits d'entretien

Baugruppe 078039
Assembly 078039
Assemblage 078039

Druckölschmierung kpl.
Lubricating system assy.
Lubrification cpl.



TM320-13

Klasse/ Class/ Classe			Pos.	Bestell-Nr. Part No. No. de cde.	Anz. Qty. Qté.	Benennung	Designation	Dénomination
a	b	c						
			40	077884	1	Druckölschmierung	Lubricating system	lubrification
			70	80384	1	Verbindungsleitung kpl.	connecting tube assy.	tuyau cpl.
			130	N20237	1	G-Einschraubstutzen	straight male stud	manchon fileté mâle
			140	N503	4	Zylinderschraube	allen screw	vis six pans creux
			150	78421	1	Dichtung	gasket	joint

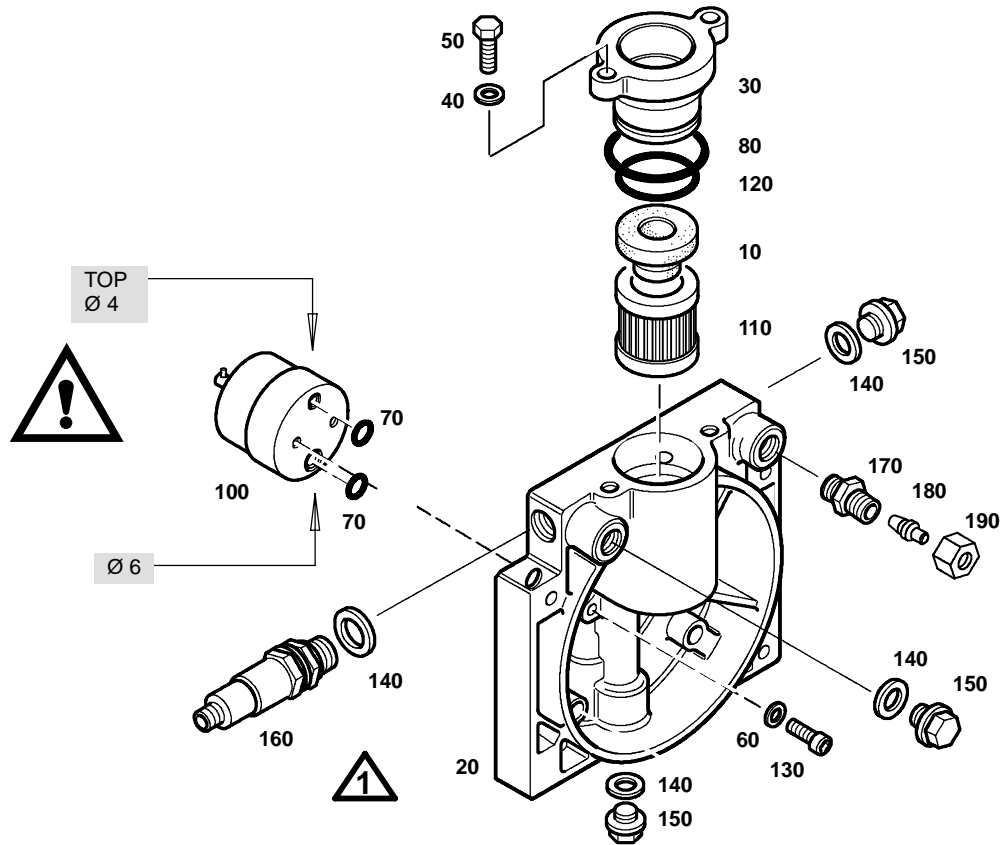

077884/12/01



 Wartungssätze
 Maintenance sets
 Kits d'entretien

Baugruppe 077884
Assembly 077884
Assemblage 077884

Druckölschmierung
Lubricating system
Lubrification

TM320-13a

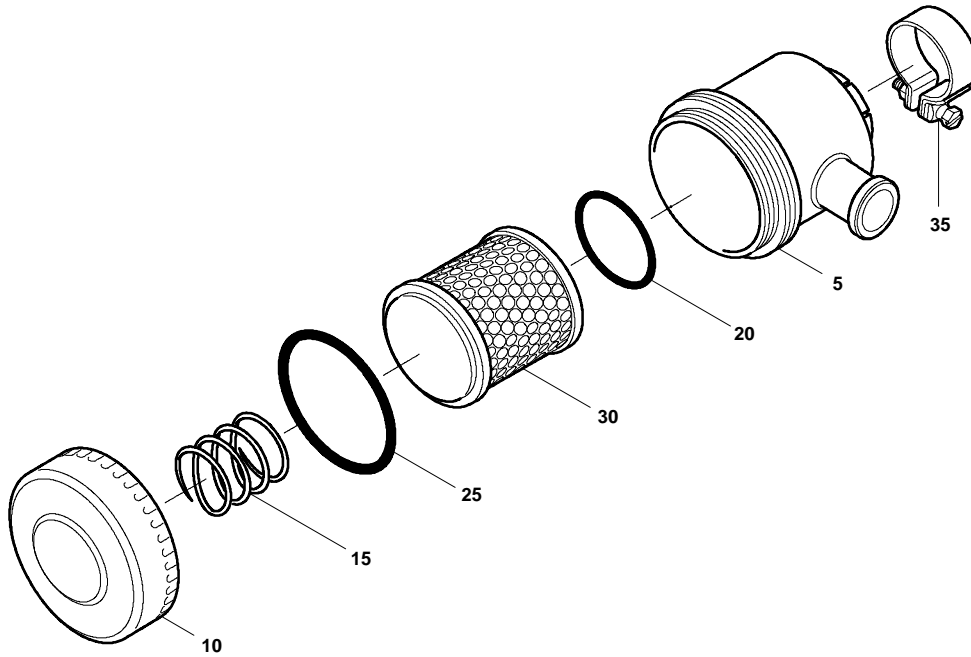
Klasse/ Class/ Classe			Pos.	Bestell-Nr. Part No. No. de cde.	Anz. Qty. Qté.	Benennung	Designation	Dénomination
a	b	c						
			10	77774	1	Dichtung Gummi	rubber gasket	joint
			20	77878	1	Deckel f. Ölpumpe	cover for oil pump	couvercle
			30	77885	1	Deckel f. Ölfilter	cover for oil filter	couvercle
			40	N58	2	Scheibe	washer	rondelle
			50	N19506	2	Sechskantschraube	hex. screw	vis hex.
			60	N2889	2	Dichtring	gasket	joint
			70	N3489	2	O-Ring	o-ring	joint torique
			80	N4058	1	O-Ring	o-ring	joint torique
			100	N24585	1	Zahnradpumpe	gear pump	pompe à huile
X			110	N25326	1	Filterelement	filter element	élément filtrant
			120	N25327	1	O-Ring	o-ring	joint torique
			130	N25328	2	Zylinderschraube	allen screw	vis six pans creux
			140	N1316	4	Dichtring	gasket	joint
			150	N52	3	Verschlusschraube	plug	bouchon fileté
			160	077970	1	Regulierventil	regulating valve	soupape régulatrice
			170	N20065	1	G-Einschraubstutzen	straight male stud	manchon fileté mâle
			180	N16309	1	Verschlussstopfen	plug	bouchon
			190	N1049	1	Überwurfmutter	screw cap 6S	écrou borgne



Ersatzteilsätze
Spare parts sets
Kits de pièces dét.

Baugruppe 013758 **Ansaugfilter**
Assembly 013758 **Intake filter**
Assemblage 013758 **Filtre d'aspiration**

TM320-14

Klasse/ Class/ Classe			Pos.	Bestell-Nr. Part No. No. de cde.	Anz. Qty. Qté.	Benennung	Designation	Dénomination
a	b	c						
			5	12770	1	Ansaugfilter-Gehäuse	intake filter housing	boîtier de filtre
			10	12771	1	Ansaugfilter-Deckel	suction filter cover	couvercle de filtre
			15	10528	1	Druckfeder	pressure spring	ressort de pression
X			20	13757	1	O-Ring	o-ring	joint torique
X			25	N4451	1	O-Ring	o-ring	joint torique
X			30	N70	1	Filtereinsatz	filter insert	élément filtrant
			35	N3374	1	Schelle	clamp	collier

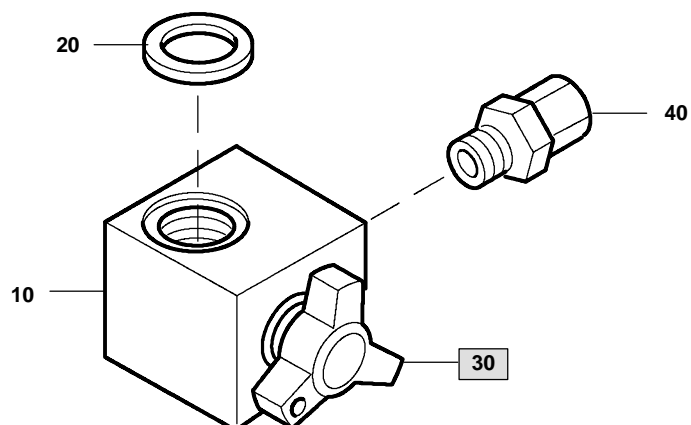
 Wartungssätze
 Maintenance sets
 Kits d'entretien

Baugruppe 78432 **Kondensatablaßhahn**
Assembly 78432 **Condensate drain tap**
Assemblage 78432 **Robinet de purge**
TM320-15

Klasse/ Class/ Classe			Pos.	Bestell-Nr. Part No. No. de cde.	Anz. Qty. Qté.	Benennung	Designation	Dénomination
0	2	5						
			10	78423	1	Ablaßhahnkörper, kpl.	drain valve body	corps de robinet de purge
X			20	N19368	1	Dichtung	gasket	joint
			30	065500	1	Knebelschraube kpl.	tommy screw assy.	molette cpl.
X			40	N24910	1	Verschraubung	hose connector	raccord

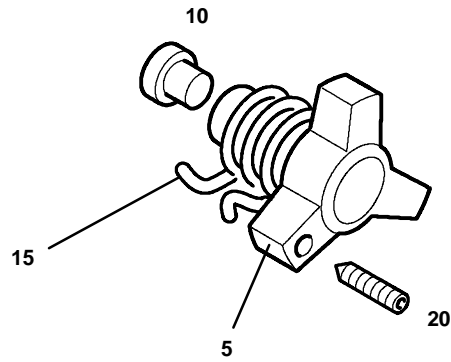

Wartungssätze
Maintenance sets
Kits d'entretien

Baugruppe 055500 **Knebelschraube mit Sicherungsfeder**
Assembly 055500 **Tommy screw with retaining spring**
Assemblage 055500 **Molette avec ressort**

TM320-15a

Klasse/ Class/ Classe			Pos.	Bestell-Nr. Part No. No. de cde.	Anz. Qty. Qté.	Benennung	Designation	Dénomination
a	b	c						
			5	11392	1	Knebelschraube	tommy screw	molette
			10	64498	1	Dichtung	gasket	joint
			15	13284	1	Sicherungsfeder	locking spring	ressort d'arrêt
			20	N16947	1	Gewindestift	stud	vis sans tête

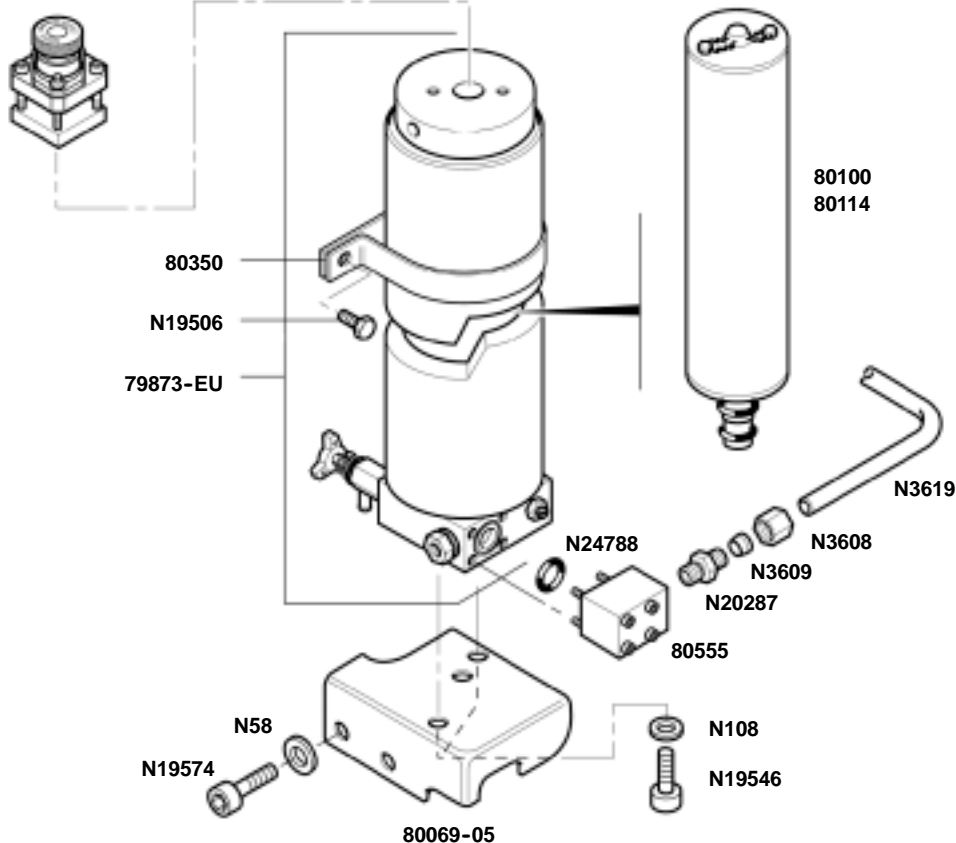
059410-225
 059410-225TÜV
 059410-330
 059410-330TÜV

 80100
 80114

80350

N19506

79873-EU

N3619

N24788

N3608

N3609

N20287

80555

N58

N108

N19574

N19546

80069-05



 Wartungssätze
 Maintenance sets
 Kits d'entretien

 Baugruppe 80067
 Assembly 80067
 Assemblage 80067

 Filtersystem P31
 Filter system P31
 Système de filtration P31

TM320-16

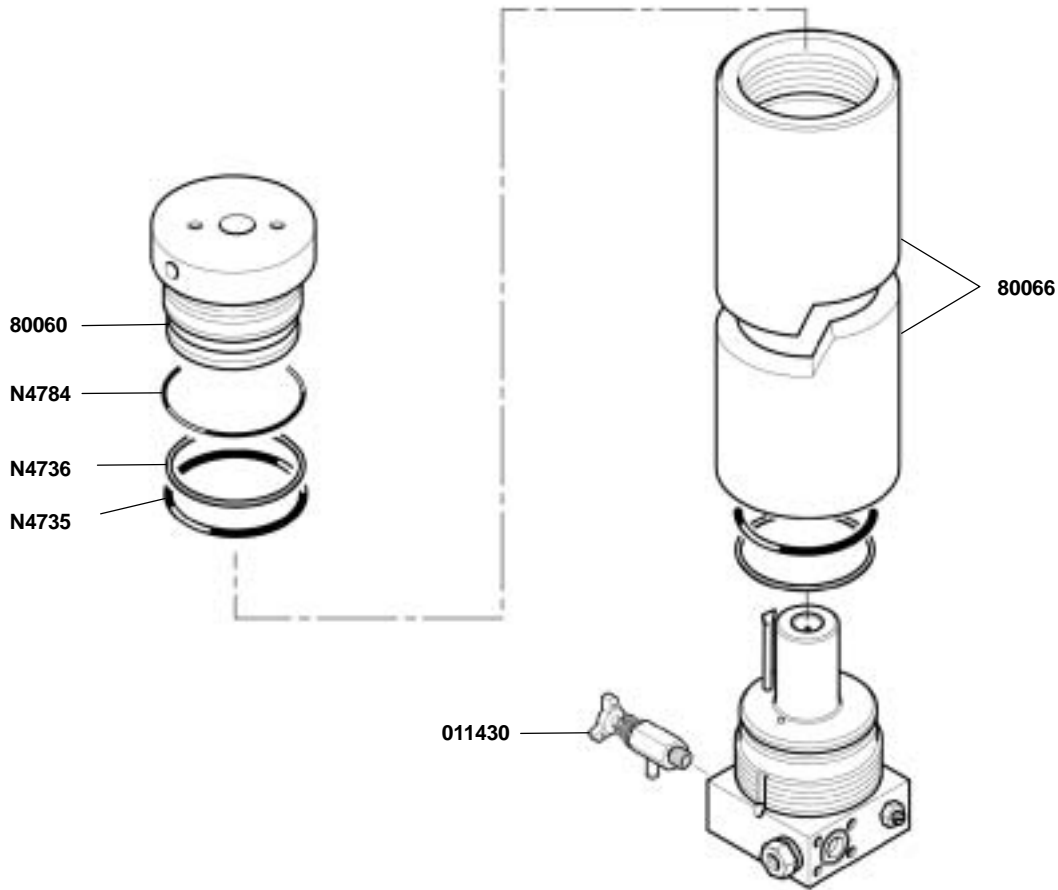
Klasse/ Class/ Classe			Bestell-Nr. Part No.	Benennung	Designation	Dénomination
a	b	c	No. de cde.			
			059410-225	Sicherheitsventil 225 bar	Safety valve 225 bar	Soupape de sûreté 225 bar
			059410-225TÜV	Sicherheitsventil 225 bar m. TÜV	Safety valve 225 bar w. TÜV	Soupape de sûreté 225 bar avec TÜV
			059410-330	Sicherheitsventil 330 bar	Safety valve 330 bar	Soupape de sûreté 330 bar
			059410-330TÜV	Sicherheitsventil 330 bar m. TÜV	Safety valve 330 bar w. TÜV	Soupape de sûreté 330 bar avec TÜV
			79873-EU	Filter P31 (ohne Patrone)	Filter P21 (without cartridge)	Syst. P21 (sans cartouche)
			80069-05	Halterung	bracket	fixation
			80100	Filterpatrone MS-AC	filter cartridge MS-AC	cartouche filtrante MS-AC
			80114	Filterpatrone MS-AC-HP	filter cartridge MS-AC-HP	cartouche filtrante MS-AC-HP
			80350	Rohrschelle	tube clamp	collier
			80555	Rückschlagventil	non-return valve	soupape anti-retour
			N58	Scheibe	washer	rondelle
			N108	Federring	lock washer	rondelle élastique
			N3608	Überwurfmutter	cap screw	écrou
			N3609	Schneidring	cutting ring	écrou borgne
			N3619	Rohr	tube	tuyau
			N19547	Zylinderschraube	allen screw	vis six pans creux
			N19546	Zylinderschraube	allen screw	vis six pans creux
			N19506	Sechskantschraube	hex. screw	vis hex.
			N20287	G-Einschraubstutzen	male connector	raccord droit mâle
			N24788	O-Ring	o-ring	joint torique



Wartungssätze
Maintenance sets
Kits d'entretien

Baugruppe 79873-EU Filterbehälter
Assembly 79873-EU Filter housing
Assemblage 79873-EU Corps du filtre

TM320-16a

Klasse/ Class/ Classe			Bestell-Nr. Part No.	Benennung	Designation	Dénomination
a	b	c	No. de cde.			
			011430	Kondensatablaßshahn kpl.	condensate drain tap assy.	robinet de purge cpl.
			80060*	Filterkopf	filter head	tête de filtre
			80066*	Filtergehäuse	filter housing	corps du filtre
			80593*	Filterboden kpl.	filter base part assy	base de filtre
			N4735	O-Ring	o-ring	joint torique
			N4736	Stützring	backup ring	bague d'appui
			N4784	O-Ring	o-ring	joint torique

			*	nur zusammen lieferbar	available only as a set	ne sont livrées qu'ensemble
--	--	--	---	------------------------	-------------------------	-----------------------------

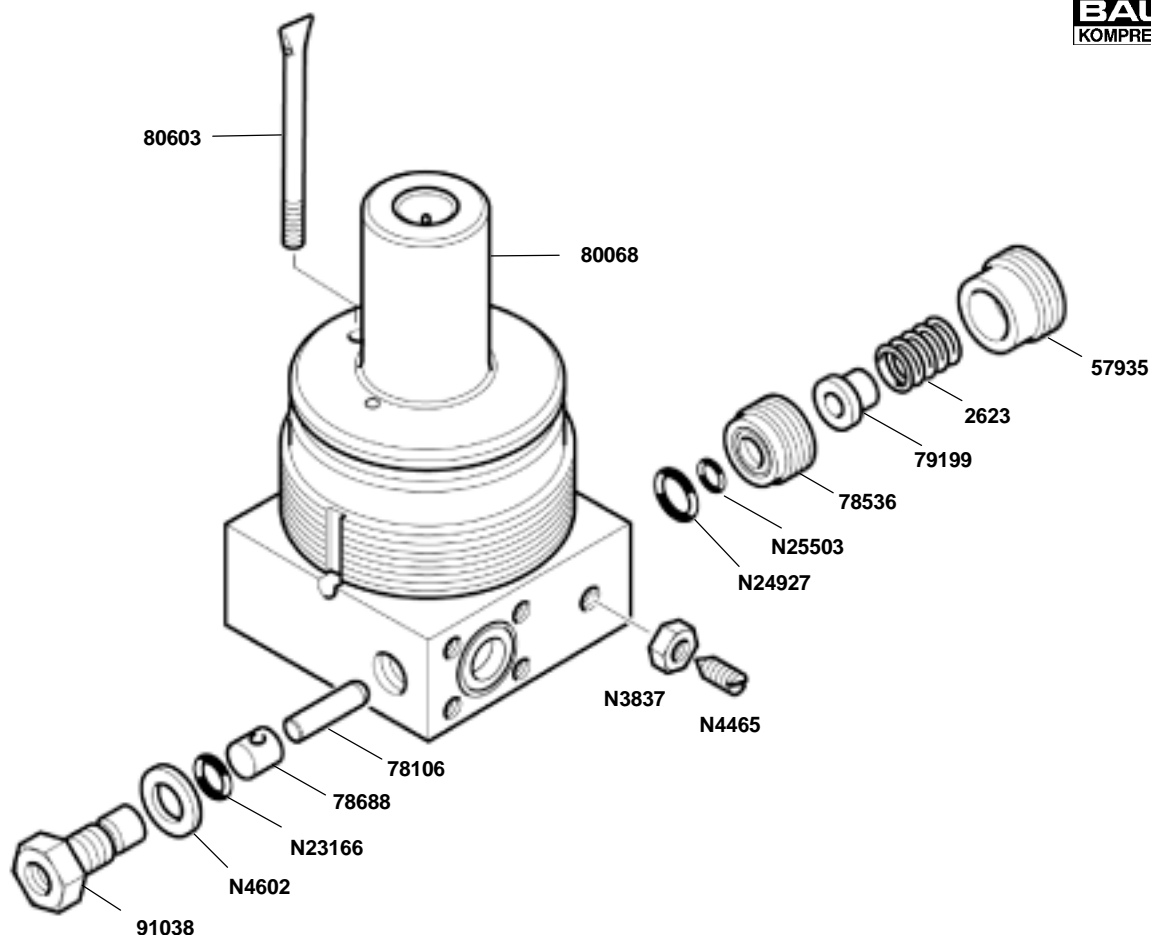

 Wartungssätze
 Maintenance sets
 Kits d'entretien

 Baugruppe 80593
 Assembly 80593
 Assemblage 80593

 Behälterboden kpl.
 Filter base part assy.
 Base du filtre cpl.

TM320-16b

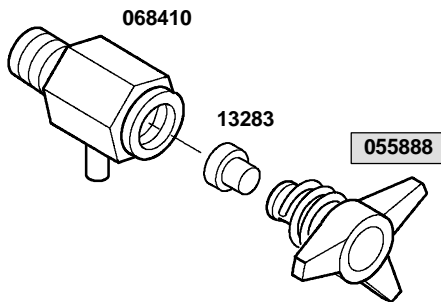
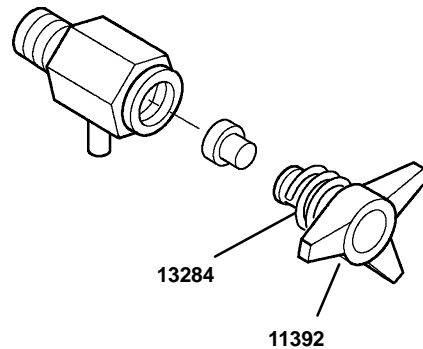
Klasse/ Class/ Classe			Bestell-Nr. Part No.	Benennung	Designation	Dénomination
a	b	c	No. de cde.			
			2623	Druckfeder	spring	ressort de pression
			57935	Einstellschraube	adjusting screw	vis d'ajustage
	X		78106	Zylinderstift	cylindric pin	tige cylindrique
			78536	Aufnahme	seat	siège
			78688	Ventilkolben	valve piston	piston
			79199	Federaufnahme	spring seat	siège de ressort
			80068	Boden	base	base
			80603	Spritzrohr	nozzle	buse
			91038	Ventilsitz	valve seat	siège de soupape
			N3837	Sechskantmutter	hex nut	écrou hex.
			N4465	Gewindestift	set screw	goujon fileté
			N4602	USIT-Ring	usit-ring	joint usit
			N23166	O-Ring	o-ring	joint torique
			N24927	O-Ring	o-ring	joint torique
			N25503	O-Ring	o-ring	joint torique



TM320-16c

TM320-16d

Wartungssätze Maintenance sets Kits d'entretien	Baugruppe 011430 Kondensatablaßhahn	TM320-16c
	Assembly 011430 Condensate drain tap	
	Assemblage 011430 Robinet de purge	

Klasse/ Class/ Classe			Bestell-Nr. Part No.	Benennung	Designation	Dénomination
a	b	c	No. de cde.			
			068410	Ablaßhahnkörper, kpl.	drain valve housing	corps de robinet de purge
X			13283	Dichtung	gasket	joint
			055888	Knebelschraube m. Feder	tommy screw with spring	molette avec ressort

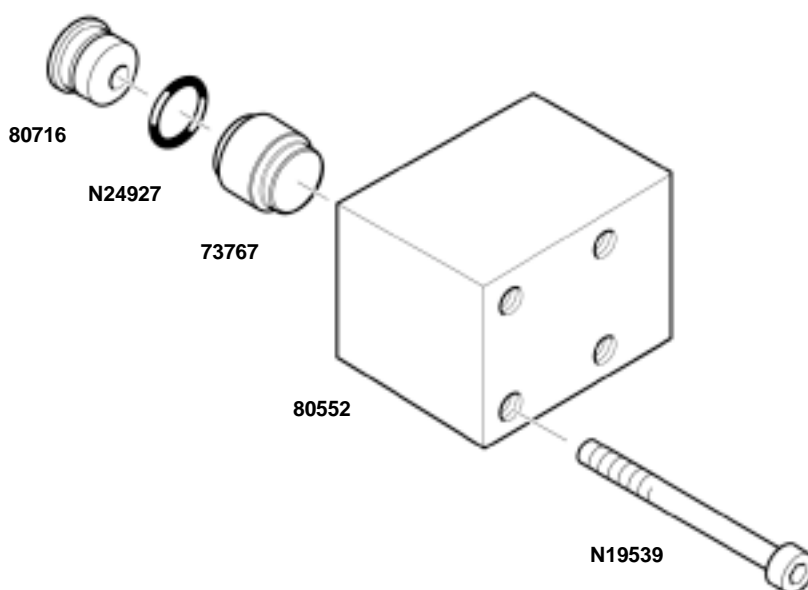
Wartungssätze Maintenance sets Kits d'entretien	Baugruppe 055888 Knebelschraube mit Sicherungsfeder	TM320-16d
	Assembly 055888 Tommy screw with retaining spring	
	Assemblage 055888 Molette avec ressort	

Klasse/ Class/ Classe			Bestell-Nr. Part No.	Benennung	Designation	Dénomination
a	b	c	No. de cde.			
			11392	Knebelschraube	tommy screw	molette
			13284	Sicherungsfeder	locking spring	ressort d'arrêt



 Wartungssätze
 Maintenance sets
 Kits d'entretien

 Baugruppe **80555**
 Assembly **80555**
 Assemblage **80555**

 Rückschlagventil
 Non-return valve assy.
 Soupape anti-retour cpl.

TM320-16e

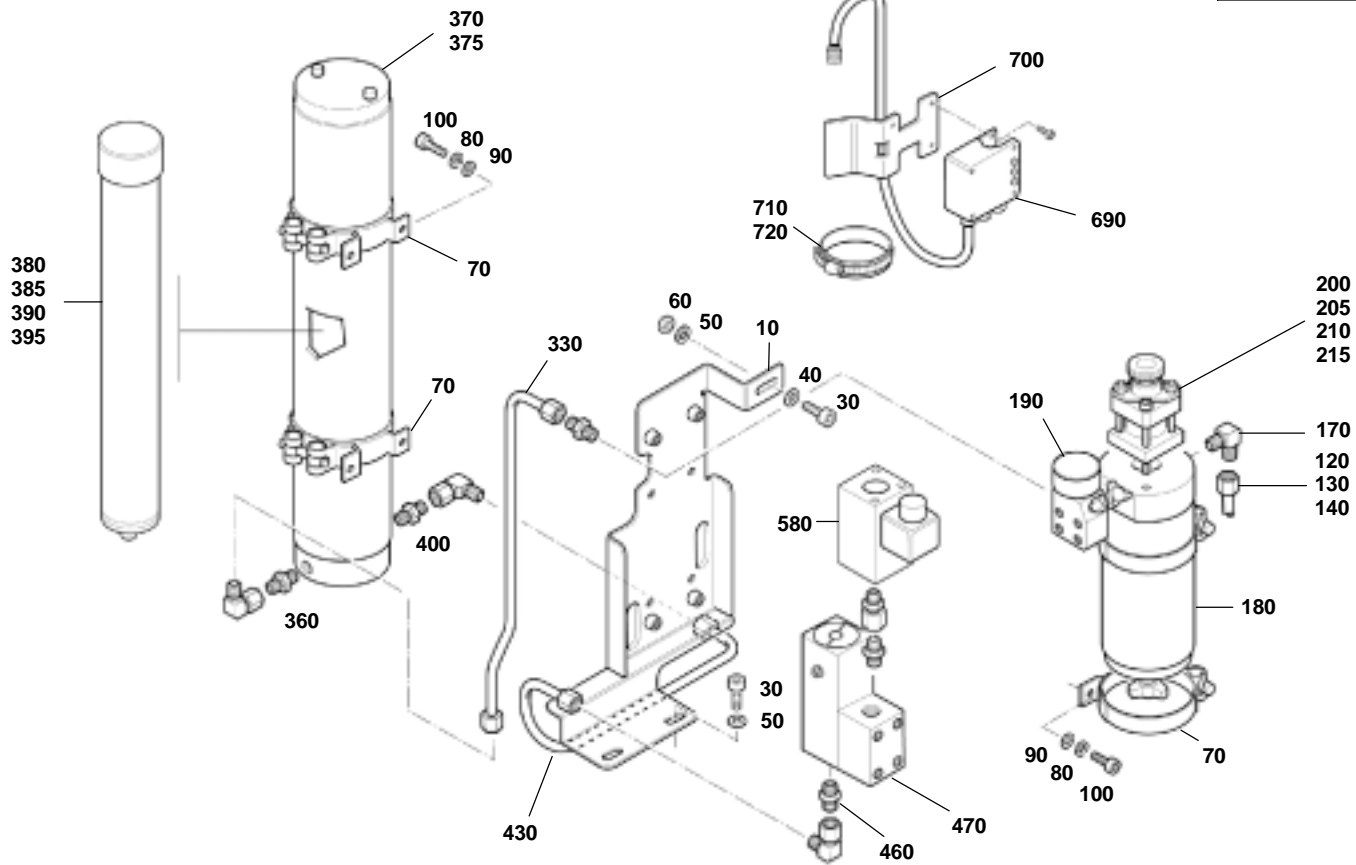
Klasse/ Class/ Classe			Bestell-Nr. Part No.	Benennung	Designation	Dénomination
a	b	c	No. de cde.			
			80552	Ventilkörper	Valve housing	Corps de soupape
			80716	Rückschlagventilsitz	Valve seat	Siège de soupape
X			N24927	O-Ring	O-ring	Joint torique
			73767	Ventilkolben	Valve piston	Piston
			N19539	Innensechskantschraube	Allen screw	Vis à six pans creux



Wartungssätze
Maintenance kits
Kits d'entretien

Baugruppe 80514
Assembly 80514
Assemblage 80514

Filtersystem P41 (Zusatzausstattung
Filtersystem P41 (optional extra)
Système de filtration P41 (optionnel)

TM320-17

Klasse/ Class/ Classe			Pos.	Bestell-Nr. Part No. No. de cde.	Benennung	Designation	Dénomination
a	b	c					
			10	80515	Halterung	braket	fixation
			30	N19534	Zylinderschraube	cylinder screw with IN-6KT	vis cylindrique avec IN-6KT
			40	N102	Scheibe	washer	rondelle
			50	N100	Federring	spring washer	rondelle-ressort
			60	N1042	Sechskantmutter	hexagon nut self-locking	écrou six pans auto-bloquant
			70	N26517	Schelle	clamp	collier
			80	N58	Scheibe	washer	rondelle
			90	N108	Federring	spring washer	rondelle-ressort
			100	N19547	Zylinderschraube	allen screw	vis allen
			110	N20208	G-Stutzen	connector	raccord
			120	N3609	Schneidring	cutting ring	rondelle de matrice
			130	N3608	Überwurfmutter	screw cap	écrou-chapeau
			140	N3619	Rohr	stainless steel tube 8x1.5	tuyau en acier inox 8x1.5
			150	N3608	Überwurfmutter	screw cap	écrou-chapeau
			160	N3609	Schneidring	cutting ring	rondelle de matrice
			170	N20270	Einst. W-Stutzen	connector	raccord
			180	090058-EU	OI- und Wasserabscheider	oil and water separator	séparateur d'huile et d'eau
			190	78122	Rückschlagventil	non-return valve	clapet anti-retour
			200	059410-225	Sicherheitsventil	safety valve	soupape de sûreté 225bar
			205	059410-225T ÜV	Sicherheitsventil	safety valve	soupape de sûreté 225bar
			210	059410-330	Sicherheitsventil	safety valve	soupape de sûreté 330bar
			215	059410-330T ÜV	Sicherheitsventil	safety valve	soupape de sûreté 330bar
			220	N4570	Verschlußschraube	plug	bouchon fileté
			230	N20270	Einst. W-Stutzen	connector	raccord
			240	N3609	Schneidring	cutting ring	rondelle de matrice
			250	N3608	Überwurfmutter	screw cap	écrou-chapeau
			260	N3619	Rohr	stainless steel tube 8x1.5	tuyau en acier inox 8x1.5
			300	N20287	G-Einschraubstutzen	union	raccord
			310	N3609	Schneidring	cutting ring	rondelle de matrice
			320	N3608	Überwurfmutter	screw cap	écrou-chapeau
			330	N3619	Rohr	stainless steel tube 8x1.5	tuyau en acier inox 8x1.5

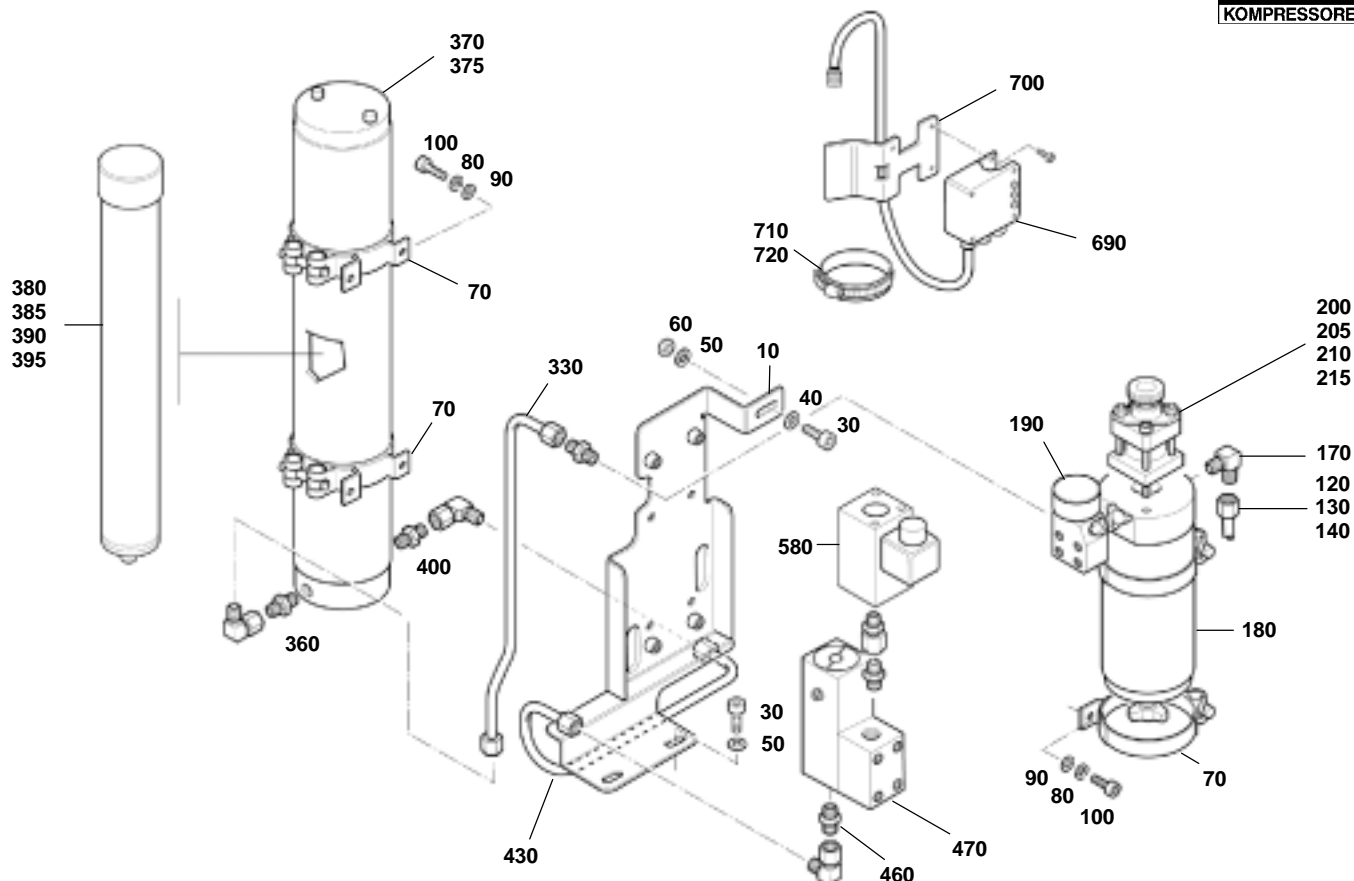
 Wartungssätze
 Maintenance kits
 Kits d'entretien

Baugruppe 80514
Assembly 80514
Assemblage 80514

Filtersystem P41 (Zusatzausstattung)
Filtersystem P41 (optional extra)
Système de filtration P41 (optionnel)
TM320-17

Klasse/ Class/ Classe			Pos.	Bestell-Nr. Part No. No. de cde.	Benennung	Designation	Dénomination
a	b	c					
			340	N3608	Überwurfmutter	screw cap	écrou-chapeau
			350	N3609	Schneidring	cutting ring	rondelle de matrice
			360	N20287	G-Einschraubstutzen	union	raccord
			370	090960-EU	Filterbehälter	filter housing	corps de filtre
			375	062042-EU	Filterbehälter	filter housing	corps de filtre
			380	062565	Filterpatrone	filter cartridge	cartouche multiplex MS-AC
			385	067224	Filterpatrone	filter cartridge	cartouche multiplex MS-AC-MS-HP
			390	061686	Filterpatrone Securus	filter cartridge Securus	cartouche multisecc MS-AC-MS
			395	061687	Filterpatrone	filter cartridge Securus	cartouche multisecc MS-AC-MS-HP
			400	N20287	G-Einschraubstutzen	union	raccord
			410	N3609	Schneidring	cutting ring	rondelle de matrice
			420	N3608	Überwurfmutter	screw cap	écrou-chapeau
			430	N3619	Rohr	stainless steel tube 8x1.5	tuyau en acier inox 8x1.5
			440	N3608	Überwurfmutter	screw cap	écrou-chapeau
			450	N3609	Schneidring	cutting ring	rondelle de matrice
			460	N20287	G-Einschraubstutzen	union	raccord
			470	80751	Druckhalte-Rückschlagventil	pressure maintaining and non-	soupape de maintien de pression
			580	N1010	Druckschalter	pressure switch 100-400bar	manostat
			590	N2949	Scheibe	washer	rondelle
			600	N635	Federring	spring washer	rondelle ressort
			610	N3869	Zylinderschraube	allen screw	vis à six pans creux
			620	N20211	G-Einschraubstutzen	straight male stud	raccord
			630	N3663	Schneidring	cutting ring 6L/S	rondelle de matrice
			640	N3610	Überwurfmutter	screw cap 6S	écrou-chapeau
			650	N3619	Rohr	stainless steel tube 8x1.5	tuyau en acier inox 8x1.5
			660	N3610	Überwurfmutter	screw cap 6S	écrou-chapeau
			670	N3663	Schneidring	cutting ring 6L/S	rondelle de matrice
			680	N20211	G-Einschraubstutzen	straight male stud	raccord
			690	N18362	Securus-Meldegerät	SECURUS indicator unit	dispositif de surveillance
			700	75377	Halterung	bracket	fixation
			701	N19534	Zylinderschraube	cylinder screw with IN-6KT	vis cylindrique avec IN-6KT
			702	N102	Scheibe	washer	rondelle
			703	N1042	Sechskantmutter	hexagon nut self-locking	écrou six pans auto-bloquant

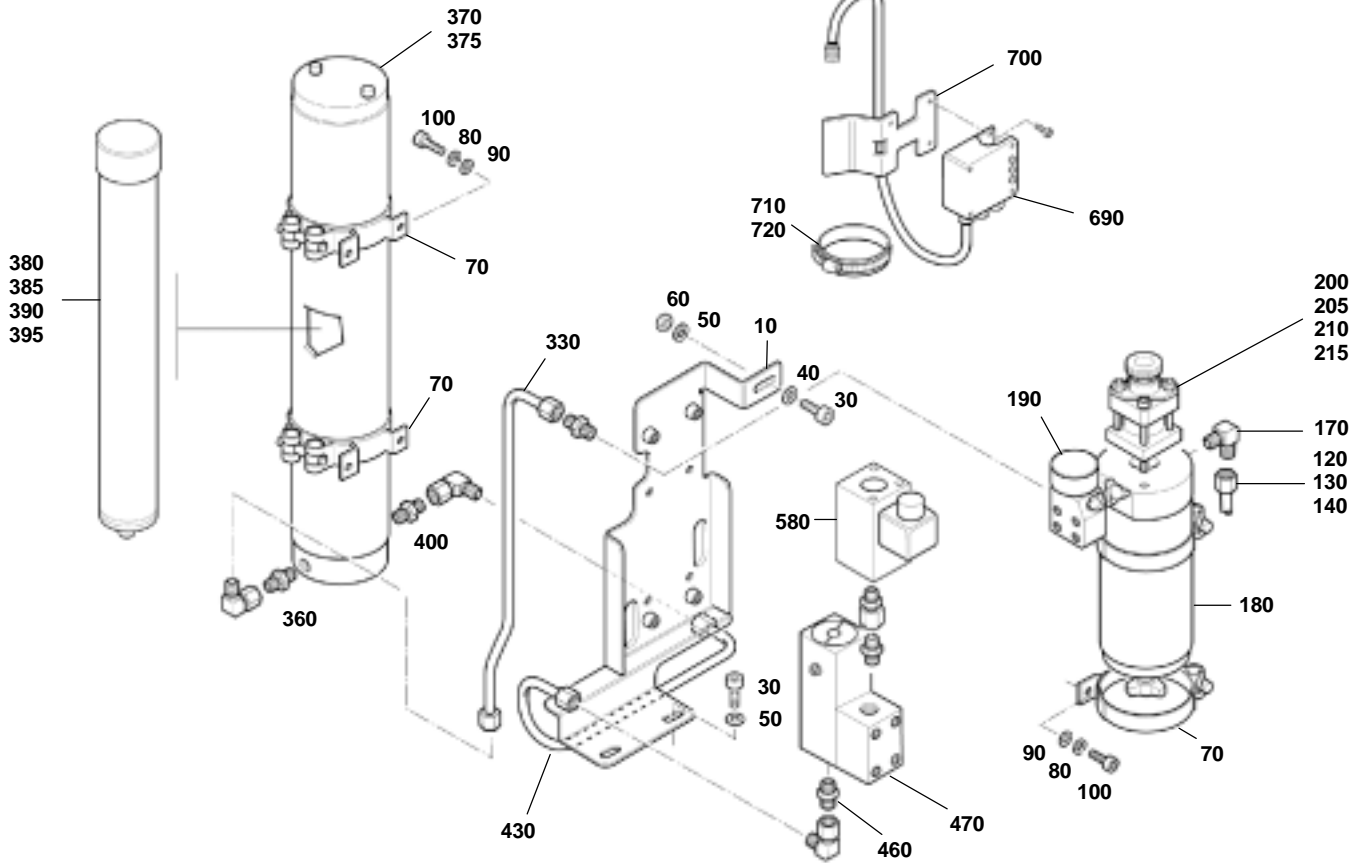

Wartungssätze
Maintenance kits
Kits d'entretien

Baugruppe 80514
Assembly 80514
Assemblage 80514

Filtersystem P41 (Zusatzausstattung)
Filtersystem P41 (optional extra)
Système de filtration P41 (optionnel)

TM320-17

Klasse/ Class/ Classe			Pos.	Bestell-Nr. Part No. No. de cde.	Benennung	Designation	Dénomination
a	b	c					
			710	N15499	Schlauchschelle	worm gear clamp	collier à filet hélicoïdal
			720	N15500	Gummiprofil	rubber profile	profilé en caoutchouc

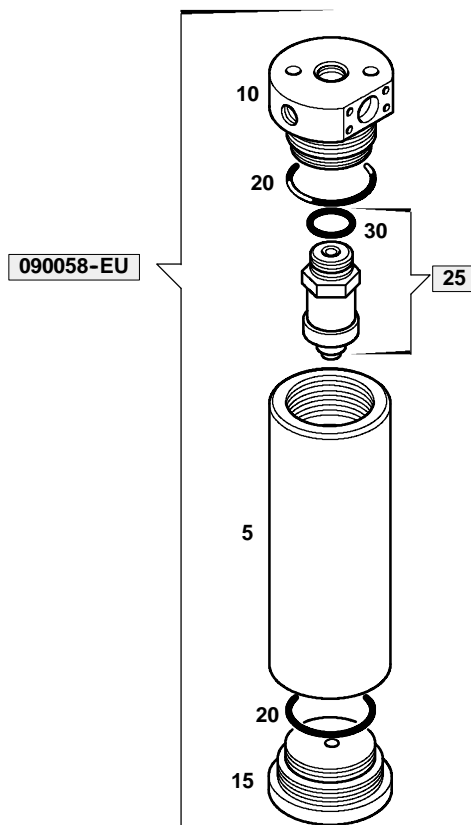
 Wartungssätze
 Maintenance kits
 Kits d'entretien

Baugruppe 090058-EU **Öl- und Wasserabscheider**
Assembly 090058-EU **Oil and water separator**
Assemblage 090058-EU **Séparateur d'huile et d'eau**
TM320-17a

Klasse/ Class/ Classe			Pos.	Bestell-Nr. Part No. No. de cde.	Anz. Qty. Qté.	Benennung	Designation	Dénomination
a	b	c						
			5	*	1	Behältergehäuse	filter housing	corps de filtre
			10	*	1	Behälterdeckel	filter head	tête de filtre
			15	*	1	Behälterboden	filter bottom	fond de filtre
X			20	N4586	2	O-Ring	o-ring	joint torique
X			25	061860	1	Microfilterpatrone	filter cartridge	cartouche de filtre
			30	N15133	1	O-Ring	o-ring	joint torique

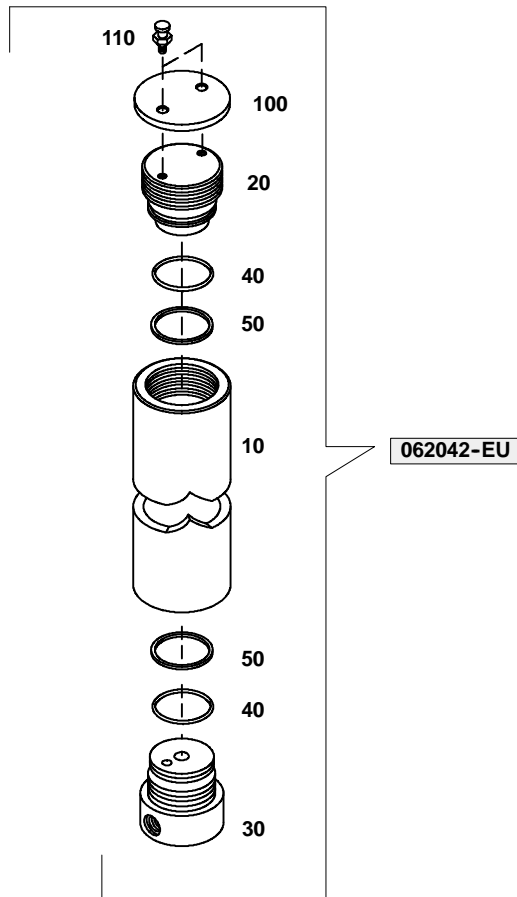

062042/07/02

 Wartungssätze
 Maintenance kits
 Kits d'entretien

Baugruppe 062042-EU **Filterbehälter kpl.**
Assembly 062042-EU **Filter housing assy.**
Assemblage 062042-EU **Corps du filtre cpl.**
TM320-17b

Klasse/ Class/ Classe			Pos.	Bestell-Nr. Part No. No. de cde.	Anz. Qty. Qté.	Benennung	Designation	Dénomination
a	b	c						
			10	*	1	Behältergehäuse	filter housing	corps de filtre
			20	*	1	Behälterdeckel kpl.	filter head	couvercle de filtre
			30	*	1	Behälterboden	filter bottom	fond de filtre
X			40	N4736	2	Stützring	back-up ring	bague d'appui
X			50	N4735	2	O-Ring	o-ring	joint torique
			60	78528	1	Fabricschild	Ident. plate	plaque d'identification
			70	N3334	1	Niete	semitubular rivet	rivet semi-tubulaire
			80	N3333	3	Blindniete	pop rivet	rivet aveugle
			90	91024	1	Klebeschild	sticker	autocollant
			100	61237	1	Schutzdeckel	protective cover	couvercle protecteur
			110	12293	2	Schraube	screw	vis

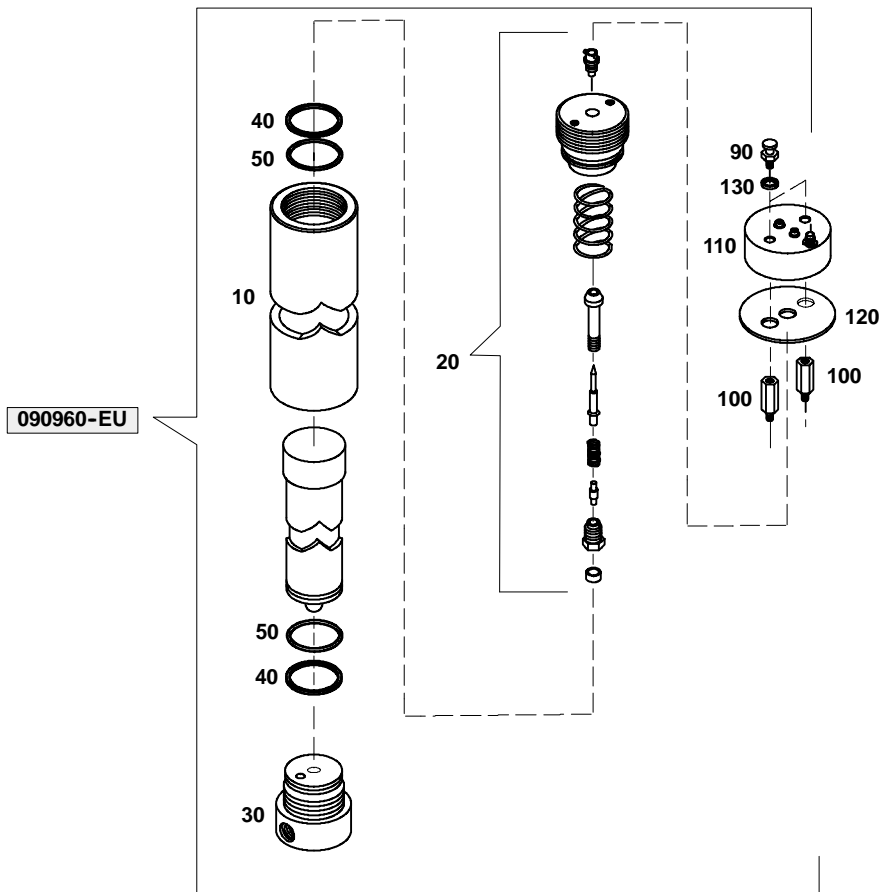

090960/07/02

 Wartungssätze
 Maintenance kits
 Kits d'entretien

Baugruppe 090960-EU
Assembly 090960-EU
Assemblage 090960-EU

Filterbehälter kpl.
Filter housing assy.
Corps du filtre cpl.
TM320-17c

Klasse/ Class/ Classe			Pos.	Bestell-Nr. Part No. No. de cde.	Anz. Qty. Qté.	Benennung	Designation	Dénomination
a	b	c						
			10	*	1	Behältergehäuse	filter housing	corps de filtre
			20	*	1	Behälterdeckel kpl.	filter top assy.	couvercle du filtre cpl.
			30	*	1	Behälterboden	filter bottom	fond du filtre
			40	N4736	2	Stützring	back-up ring	bague d'appui
			50	N4735	2	O-Ring	o-ring	joint torique
			60		1	Fabrikschild	ident. plate	plaque d'identification
			70	N3334	1	Niet	semitubular rivet	rivet semi-tubulaire
			80	N3333	3	Blindniet	pop rivet	rivet aveugle
			90	12293	2	Schraube	fastening screw	vis de fixation
			100	90765	2	Sechskant	distance bolt	boulon d'écartement
			110	78705	1	SECURUS	SECURUS (Exchange for 090570)	SECURUS
			120	90715	1	Dichtung	gasket	joint
			130	N20648	2	USIT-Ring	USIT-ring	joint USIT
			140	91025	1	Klebeschild	sticker	auto-collant

*

Nur zusammen lieferbar

Only available together

Ne sont livrées qu'ensemble

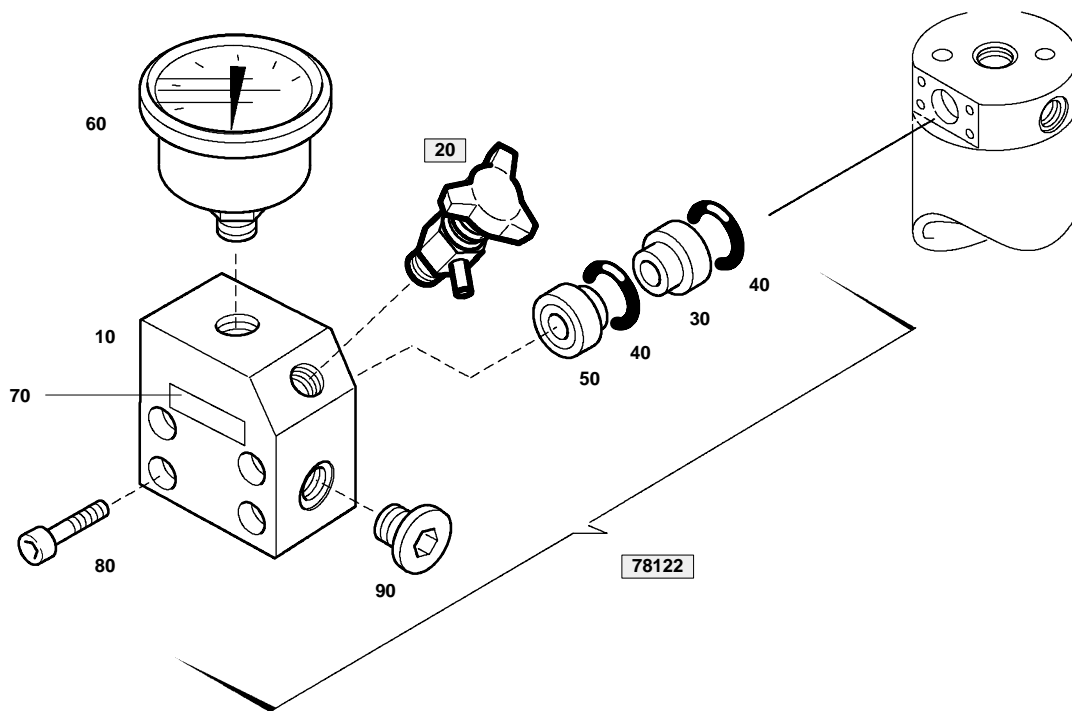
 Wartungssätze
 Maintenance kits
 Kits d'entretien

Baugruppe 78122 **Rückschlagventil**
Assembly 78122 **Non-return valve**
Assemblage 78122 **Soupape anti-retour**
TM320-17d

Klasse/ Class/ Classe			Pos.	Bestell-Nr. Part No. No. de cde.	Anz. Qty. Qté.	Benennung	Designation	Dénomination
a	b	c						
			10	78123	1	Ventilkörper	valve housing	corps de soupape
			20	011430	1	Knebelschraube	condensate drain knob	robinet de purge
			30	63843	1	Ventilsitz	non-return valve seat	siège de clapet anti-ret.
			40	N4178	2	O-Ring	o-ring	joint torique
			50	73767	1	Ventilkolben	valve piston	soupape de piston
			60	N17062	1	Manometer	gauge	manomètre
			70	64179	1	Schild	label	vignette
			80	N19538	4	Zylinderschraube	cylinder screw	vis à six pans creux
			90	N16394	1	Verschlussschraube	plug	bouchon

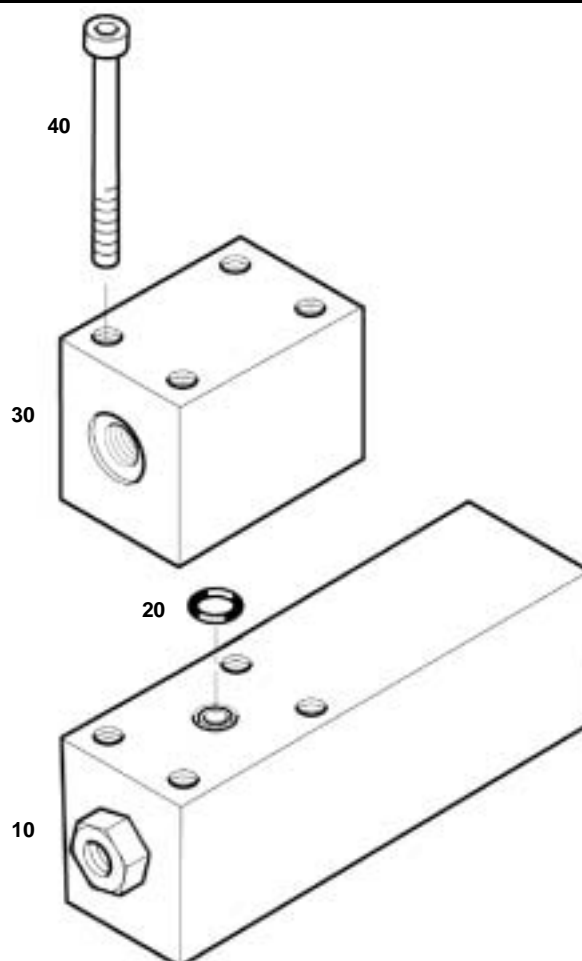

 Wartungssätze
 Maintenance kits
 Kits d'entretien

 Baugruppe 80751
 Assembly 80751
 Assemblage 80751

 Druckhalte-Rückschlagventil
 Pressure maintaining and non-return valve
 Soupape de maintien de pression anti-retour

TM320-17e

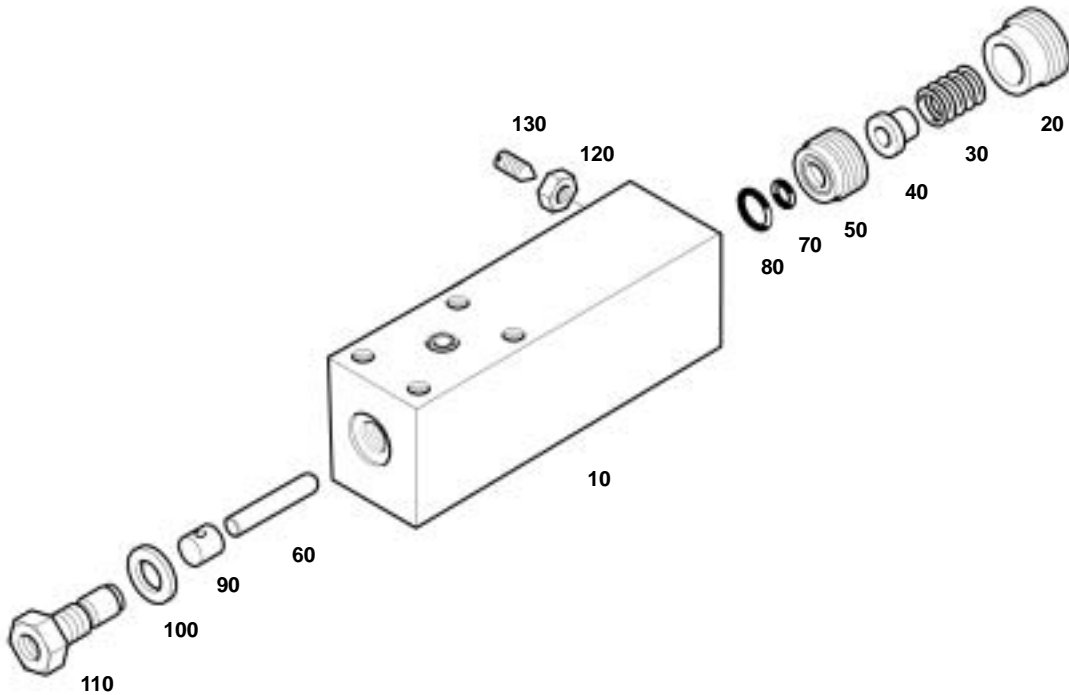
Klasse/ Class/ Classe			Pos.	Bestell-Nr. Part No. No. de cde.	Benennung	Designation	Dénomination
a	b	c					
			10	80719	Druckhalteventil	pressure maintaining valve	soupape de maintien de pression
			20	N3824	O-Ring	o-ring	joint torique
			30	80763	Rückschlagventil	non-return valve	soupape anti-retour
			40	N19538	Zylinderschraube	screw	vis



 Wartungssätze
 Maintenance kits
 Kits d'entretien

 Baugruppe 80719
 Assembly 80719
 Assemblage 80719

 Druckhalteventil
 Pressure maintaining valve
 Soupape de maintien de pression

TM320-17f

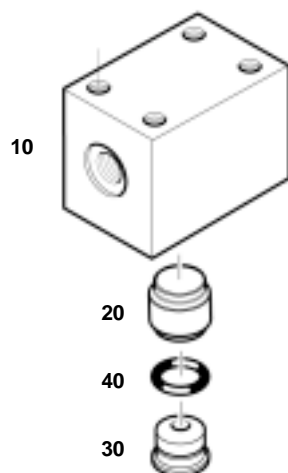
Klasse/ Class/ Classe			Pos.	Bestell-Nr. Part No. No. de cde.	Anz. Qty. Qté.	Benennung	Designation	Dénomination
a	b	c						
			10	80720	1	Ventilkörper	valve housing	corps de soupape
			20	57935	1	Einstellschraube	adjusting screw	vis d'ajustage
			30	2623	1	Druckfeder	spring	ressort de pression
			40	57762	1	Aufnahme	spring seat	siège de ressort
			50	78536	1	Aufnahme	seat	siège
			60	77245	1	Zylinderstift	cylinder stud	goupille cylindrique
			70	N25503	1	O-Ring	o-ring	joint torique
			80	N24927	1	O-Ring	o-ring	joint torique
			90	78688	1	Ventilkolben	valve piston	piston
			100	N4602	1	USIT-Ring	usit-ring	joint usit
			110	63841	1	Ventilsitz	valve seat	siège de soupape
			120	N3837	1	Sechskantmutter	hexagon nut self-locking	écrou hexagonal auto-freinant
			130	N4465	1	Gewindestift	set screw	goujon fileté



 Wartungssätze
 Maintenance kits
 Kits d'entretien

 Baugruppe 80763
 Assembly 80763
 Assemblage 80763

 Rückschlagventil
 Non-return valve
 Soupape anti-retour

TM320-17g

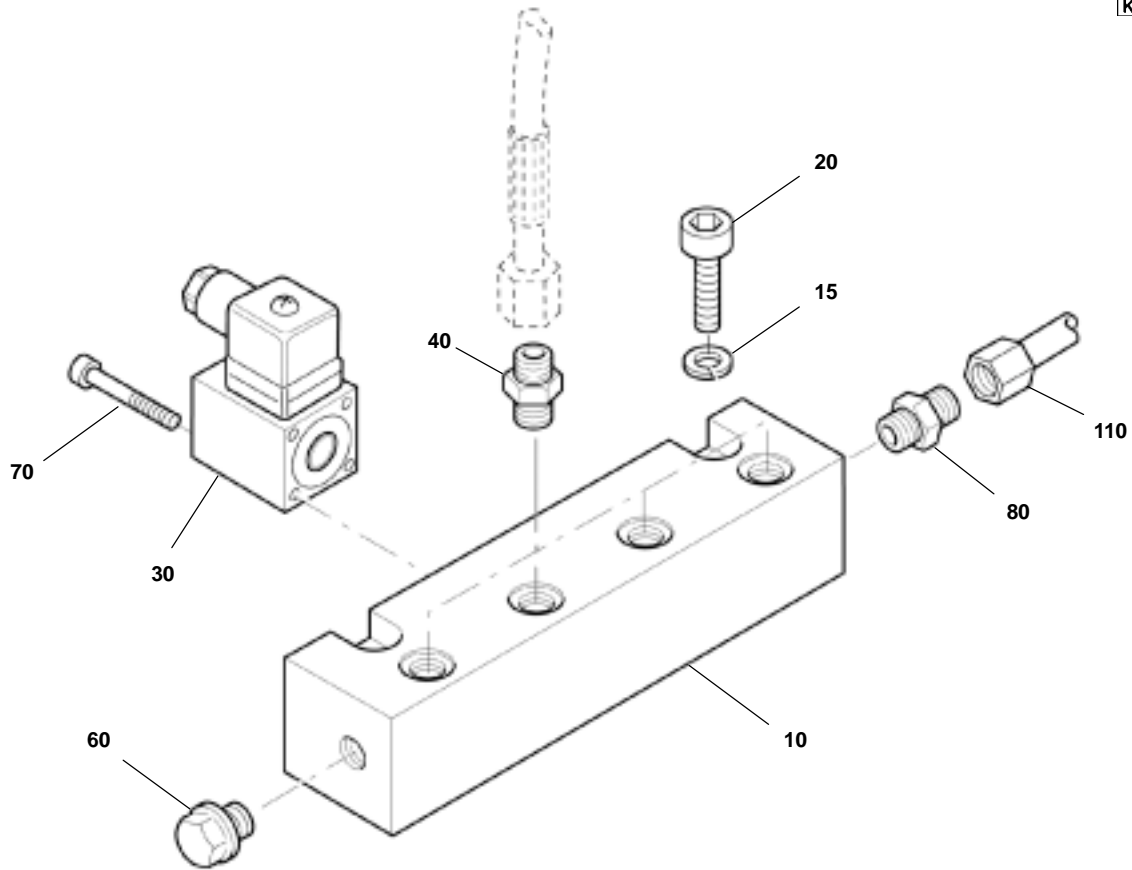
Klasse/ Class/ Classe			Pos.	Bestell-Nr. Part No. No. de cde.	Anz. Qty. Qté.	Benennung	Designation	Dénomination
a	b	c						
			10	80746	1	Ventilkörper	valve housing	corps de soupape
			20	73767	1	Ventilkolben	valve piston	soupape de piston
			30	80716	1	Ventilsitz	valve seat	siège de soupape
			40	N24927	1	O-Ring	o-ring	joint torique

 Wartungssätze
 Maintenance sets
 Kits d'entretien

Baugruppe 80626
Assembly 80626
Assemblage 80626

Fülleiste
Filling device
Listeau de remplissage
TM320-18

Klasse/ Class/ Classe			Pos.	Bestell-Nr. Part No. No. de cde.	Benennung	Designation	Dénomination
a	b	c					
			10	80448-01	Sammelleiste	distributor	listeau collecteur
			15	N108	Federring	spring washer	rondelle-ressort
			20	N19552	Zylinderschraube	allen screw	vis à six pans creux
			30	N23001	Druckschalter	pressure switch	manostat
			40	78803	UNIMAM-Verschraubung	UNIMAM connector	raccord UNIMAM
			60	N4570	Verschlussschraube	plug	bouchon fileté
			70	N821	Zylinderschraube	allen screw	vis à six pans creux
			80	N20211	G-Einschraubstutzen	straight male stud	raccord droit mâle
			110	80702	Verbindungsleitung kpl.	connecting tube assy.	tuyau cpl.

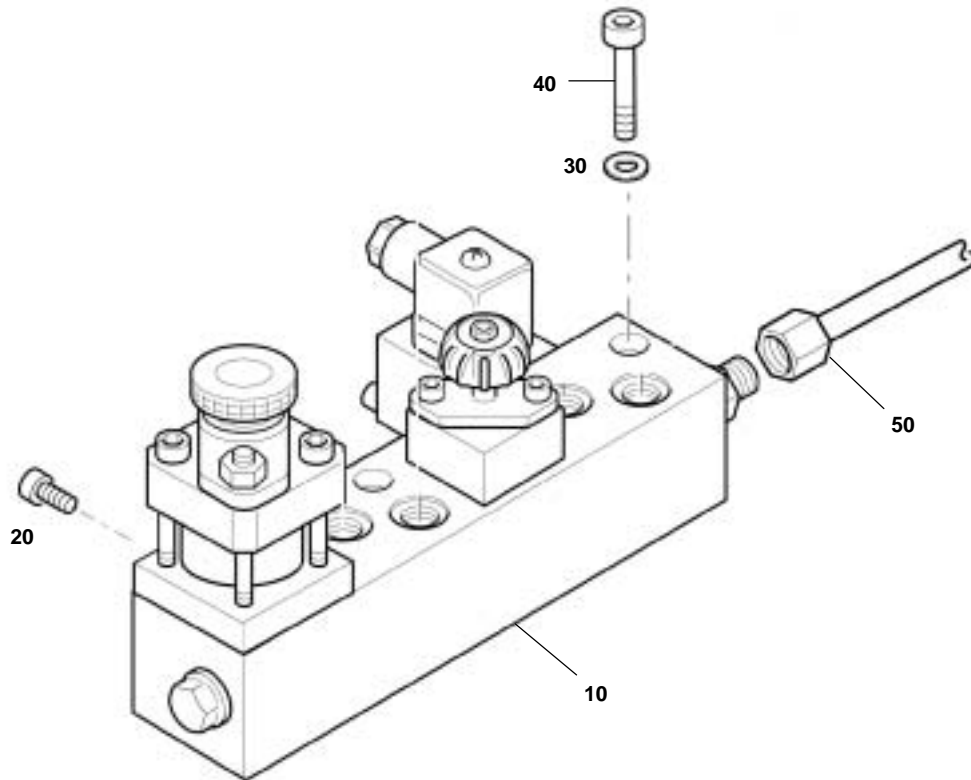
 Wartungssätze
 Maintenance sets
 Kits d'entretien

Baugruppe 80626-01 Umschalteinrichtung
Assembly 80626-01 Switch-over device
Assemblage 80626-01 Sélecteur

TM320-19

Klasse/ Class/ Classe			Pos.	Bestell-Nr. Part No. No. de cde.	Benennung	Designation	Dénomination
a	b	c					
			10	80617	Umschalteinrichtung kpl.	switch-over device assy	listeau de sélection cpl.
			20	N19556	Zylinderschraube	allen screw	vis allen
			30	N108	Federring	spring washer	rondelle-ressort
			40	N821	Zylinderschraube	allen screw	vis allen
			50	80702	Verbindungsleitung kpl.	connecting line assy.	conduite de connexion cpl.

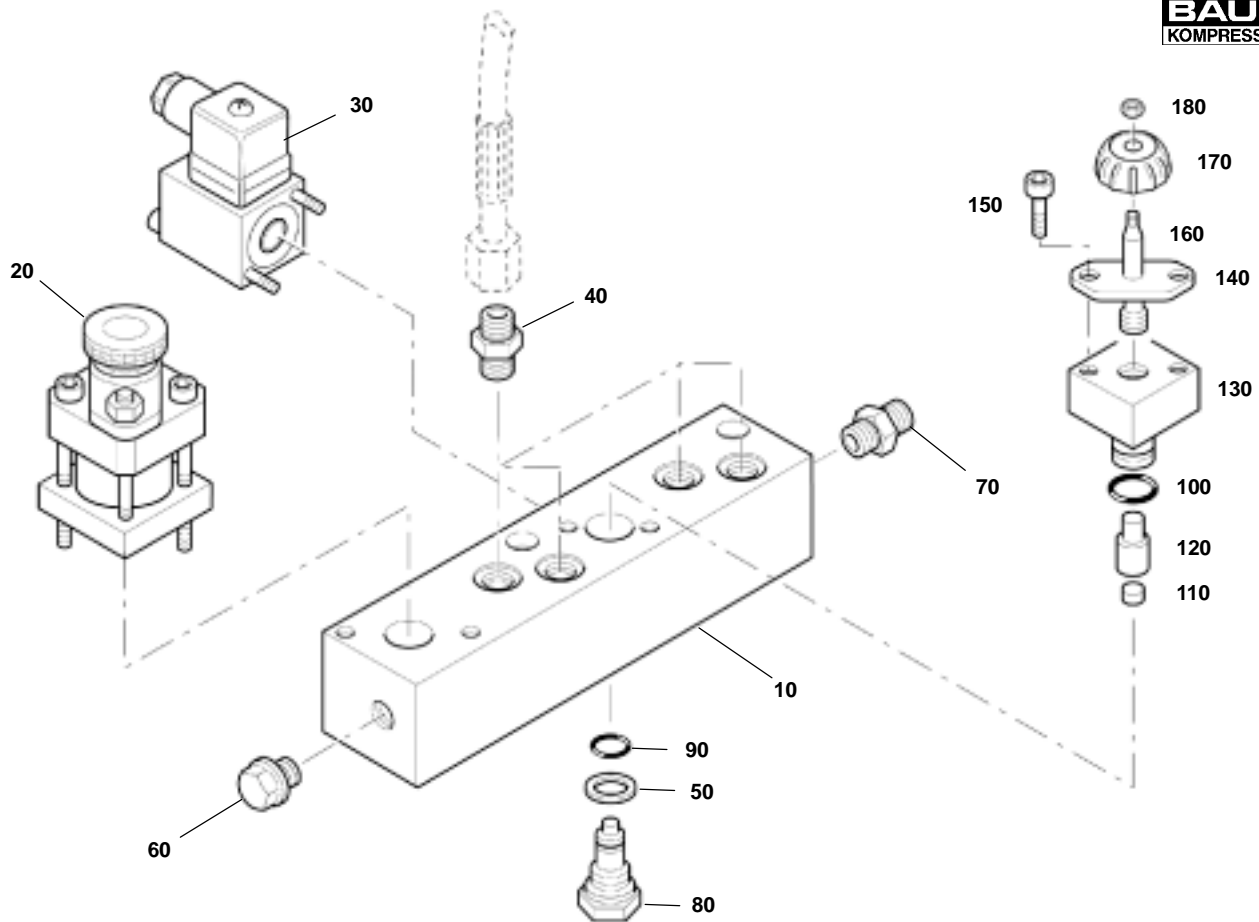
 Wartungssätze
 Maintenance sets
 Kits d'entretien

Baugruppe 80617
Assembly 80617
Assemblage 80617

Umschaltleiste
Switch-over manifold
Rampe de sélection
TM320-19a

Klasse/ Class/ Classe			Pos.	Bestell-Nr. Part No. No. de cde.	Benennung	Designation	Dénomination
a	b	c					
			10	80611	Umschaltleiste	manifold	rampe
			20	059410	Sicherheitsventil	safety valve	soupape de sûreté
			30	N23001	Druckschalter	pressure switch	manostat
			40	65363	Unimam-Verschraubung	Unimam connector	raccord Unimam
			50	N4602	USIT-Ring	USIT ring	joint USIT
			60	N52	Verschlußschraube	plug	bouchon
			70	N20195	GE-Einschraubverschraubung	male connector	raccord
			80	74530	Ventilsitz	valve seat	siège de soupape
			90	N16591	O-Ring	o-ring	joint torique
			100	N17654	O-Ring	o-ring	joint torique
			110	N17080	Dichtung	gasket	joint
			120	074860	Dichtsitz	seal	siège d'étanchéité
			130	80628	Flansch	flange	bride
			140	74390	Blech	sheet metal	plaque de fixation
			150	N19550	Zylinderschraube	allen screw	vis allen
			160	75316	Spindel	spindle	spindle
			170	N1865	Drehknopf	knob	molette
			180	N2488	Mutter	nut	écrou

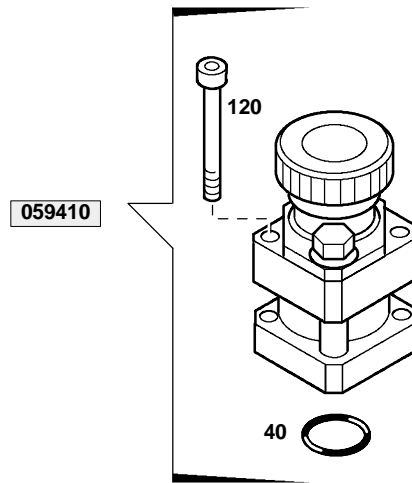

Wartungssätze
Maintenance sets
Kits d'entretien

Baugruppe 059410
Assembly 059410
Assemblage 059410

Sicherheitsventil
Safety valve
Soupape de sûreté

TM320-19b

Klasse/ Class/ Classe			Pos.	Bestell-Nr. Part No. No. de cde.	Benennung	Designation	Dénomination
a	b	c					
			40	N4882	O-Ring	o-ring	joint torique
			120	N19555	Zylinderschraube	screw	vis

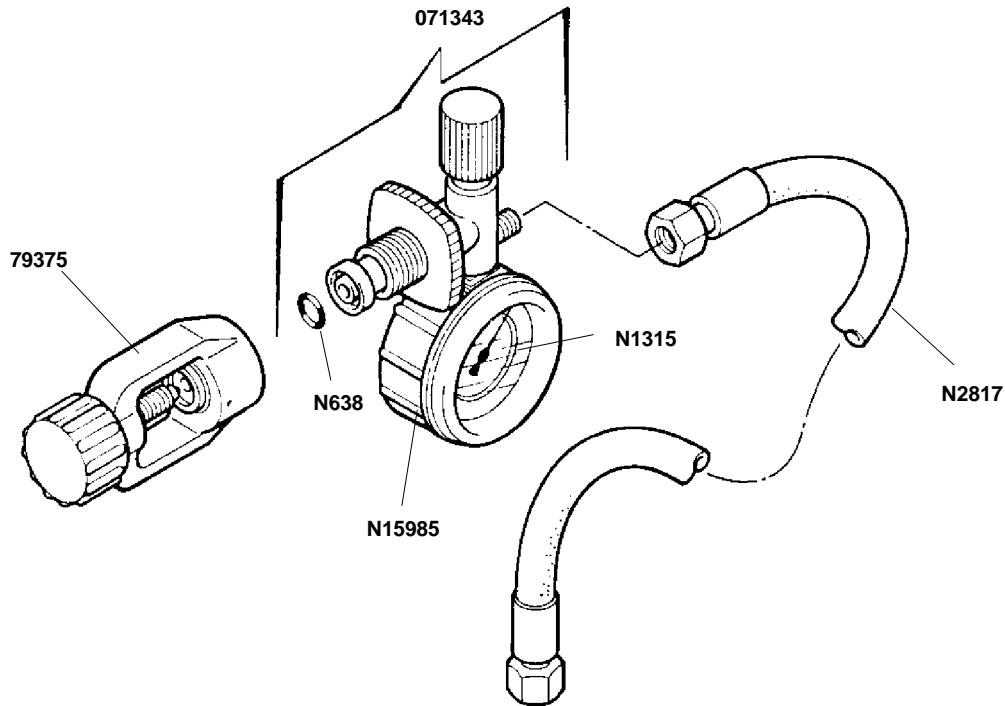

 Wartungssätze
 Maintenance sets
 Kits d'entretien

Bildtafel
Figure
Planche
014355
014355
014355
Fülleinrichtung 200 bar
Filling device 200 bar
Dispositif de remplissage 200 bar
TM320-20

Klasse/ Class/ Classe			Bestell-Nr. Part No. No. de cde.	Benennung	Designation	Dénomination
a	b	c				
			071343	Füllventil	Filling valve	Vanne de remplissage
			65594	Banderole	Ribbon	bandelette
			79375	Internat. Füllanschlußbügel	International connection	Raccord international
			N2817	Füllschlauch	Filling hose	Tuyau de remplissage

Ersatzteile/spares/pièces détachées:

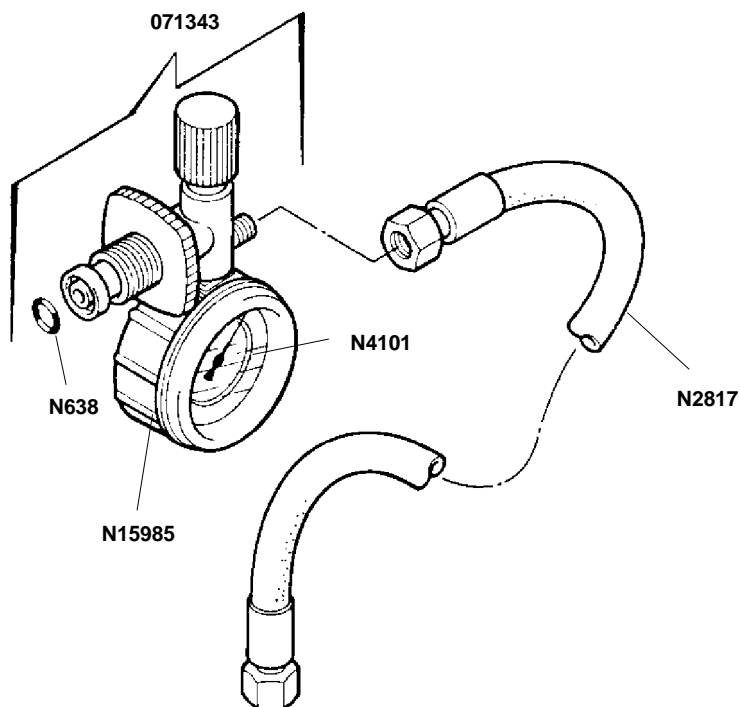
	X		072349	Reparaturatz für Füllventil	Repair kit for filling valve	Kit de rép. p. vanne de remplissage
			N638	O-Ring	O-ring	Joint torique
			N1315	Manometer	Pressure gauge	Manomètre
			N15985	Schutzkappe	Protection cap	Chapeau de protection



 Wartungssätze
 Maintenance sets
 Kits d'entretien

Bildtafel
Figure
Planche
014356
014356
014356
Fülleinrichtung 300 bar
Filling device 300 bar
Dispositif de remplissage 300 bar
TM320-21

Klasse/ Class/ Classe			Bestell-Nr. Part No. No. de cde.	Benennung	Designation	Dénomination
a	b	c				
			071344	Füllventil	Filling valve	Vanne de remplissage
			65595	Bänderole	Ribbon	bandelette
			N2817	Füllschlauch	Filling hose	Tuyau de remplissage

Ersatzteile/spares/pièces détachées:

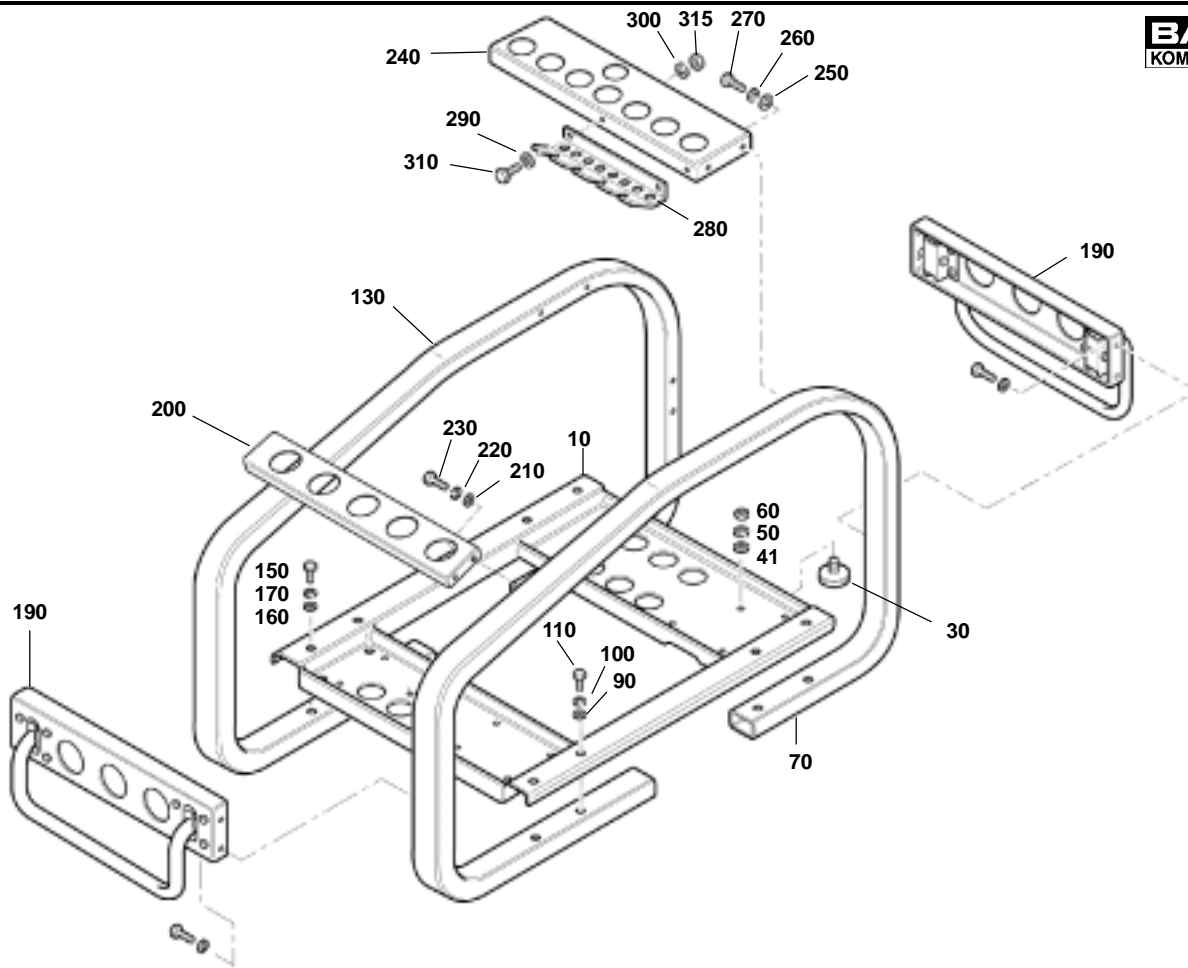
	X		072349	Reparatursatz für Füllventil	Repair kit for filling valve	Kit de rép. p. vanne de remplissage
			N638	O-Ring	O-ring	Joint torique
			N4101	Manometer	Pressure gauge	Manomètre
			N15985	Schutzkappe	Protection cap	Chapeau de protection





 Wartungssätze
 Maintenance sets
 Kits d'entretien

Baugruppe 79863 **Rahmen**
Assembly 79863 **Frame**
Assemblage 79863 **Cadre**

TM320-22

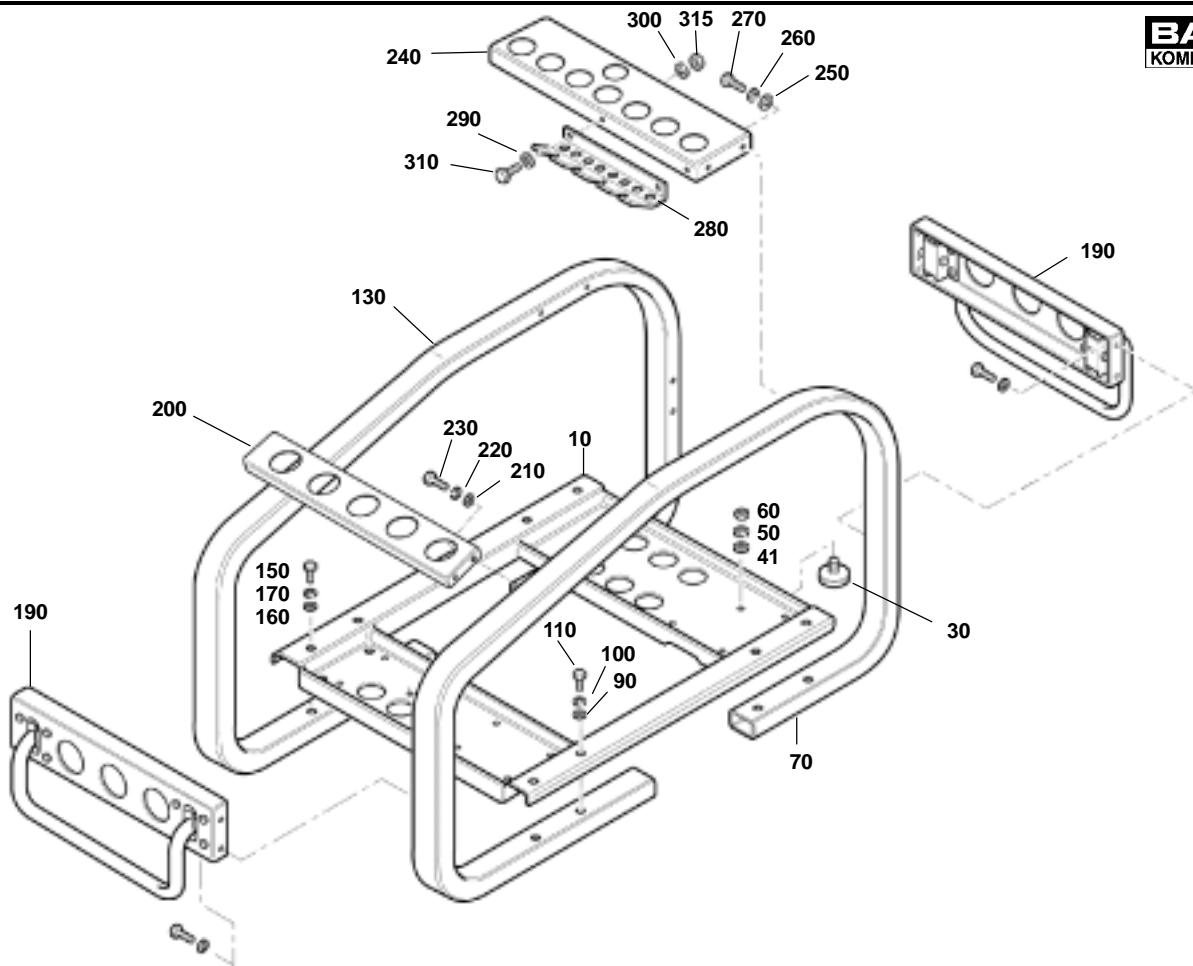
Klasse/ Class/ Classe			Pos.	Bestell-Nr. Part No. No. de cde.	Benennung	Designation	Dénomination
a	b	c					
			10	79863-02	Rahmen -RAL 7024	frame -RAL 7024	cadre -RAL 7024
			30	N26561	Schwingmetall	vibration isolator	silent-bloc
			40	N16	Scheibe	washer	rondelle
			45	N8999	Federring	lock washer	rondelle élastique
			60	N644	Sechskantmutter	hexagon nut self-locking	ecrou hexagonal auto-freinant
			70	79863-01	Rahmen -RAL 9006	frame -RAL 9006	cadre -RAL 9006
			90	N58	Scheibe	washer	rondelle
			100	N108	Federring	spring washer	rondelle-ressort
			110	N19506	Sechskantschraube	screw	vis
			120	N26426	Verschlussstopfen	plug	bouchon
			130	79863-03	Rahmen -RAL 9006	frame -RAL 9006	cadre -RAL 9006
			150	N19506	Sechskantschraube	screw	vis
			160	N58	Scheibe	washer	rondelle
			170	N108	Federring	spring washer	rondelle-ressort
			180	N26426	Verschlussstopfen	plug	bouchon
			190	79959	Griff kpl.	handle assy.	poignée cpl.
			200	80009	Halterung	bracket	fixation
			210	N58	Scheibe	washer	rondelle
			220	N108	Federring	spring washer	rondelle-ressort
			230	N19548	Zylinderschraube	allen screw	vis à six pans creux
			240	80009-01	Halterung	bracket	fixation
			250	N58	Scheibe	washer	rondelle
			260	N108	Federring	spring washer	rondelle-ressort
			270	N19548	Zylinderschraube	allen screw	vis à six pans creux
			280	80009-02	Halterung	bracket	fixation
			290	N102	Scheibe	washer	rondelle
			300	N100	Federring	spring washer	rondelle-ressort
			310	N19535	Zylinderschraube	allen screw	vis à six pans creux
			320	79938	Halterung	bracket	fixation
			330	N58	Scheibe	washer	rondelle
			340	N108	Federring	spring washer	rondelle-ressort
			350	N19548	Zylinderschraube	allen screw	vis à six pans creux





 Wartungssätze
 Maintenance sets
 Kits d'entretien

Baugruppe 79863 **Rahmen**
Assembly 79863 **Frame**
Assemblage 79863 **Cadre**

TM320-22

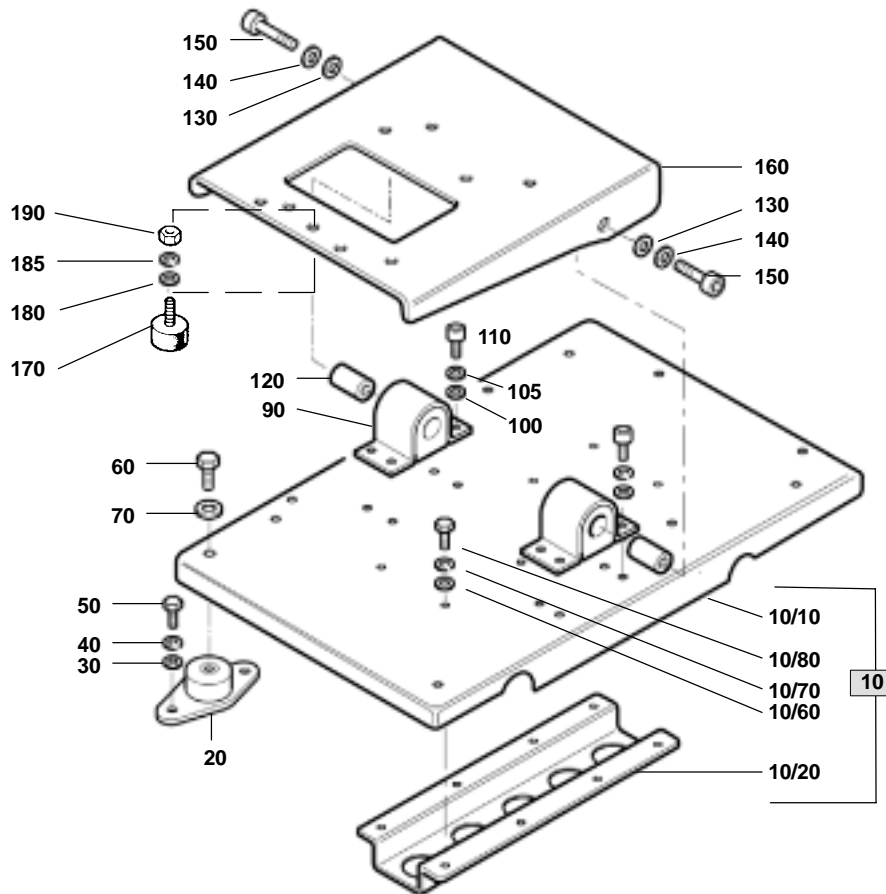
Klasse/ Class/ Classe			Pos.	Bestell-Nr. Part No. No. de cde.	Benennung	Designation	Dénomination
a	b	c					
			360	N58	Scheibe	washer	rondelle
			370	N19548	Zylinderschraube	allen screw	vis à six pans creux





 Wartungssätze
 Maintenance sets
 Kits d'entretien

Bildtafel **80080** **Schwingrahmen kpl.**
Figure **80080** **Antivibration frame**
Planche **80080** **Châssis antivibration cpl.**

TM320-22a

Klasse/ Class/ Classe			Pos.	Bestell-Nr. Part No. No. de cde.	Benennung	Designation	Dénomination
a	b	c					
			10	80078	Schwingrahmen kpl.	anti-vibration frame	châssis antivibration
			20	N26164	Schwingmetall	shock mount	amortisseur
			30	N58	Scheibe	washer	rondelle
			40	N108	Federring	lock washer	rondelle-ressort
			50	N19458	Sechskantschraube	hex screw	vis six pans
			60	N891	Sechskantschraube	hex screw	vis six pans
			70	N1594	Scheibe	washer	rondelle
			90	N26436	Schwingmetall	shock mount	amortisseur
			100	N58	Scheibe	washer	rondelle
			105	N108	Federring	lock washer	rondelle-ressort
			110	N19548	Zylinderschraube	allen screw	vis allen
			120	79862	Bolzen	pin	axe
			130	N58	Scheibe	washer	rondelle
			140	N108	Federring	lock washer	rondelle-ressort
			150	N19506	Sechskantschraube	hex screw	vis six pans
			160	79859-03	Motorwippe	hinged motor plate	bascule du moteur
			170	N26414	Schwingmetall	shock mount	amortisseur
			180	N4665	Scheibe	washer	rondelle
			185	N3313	Federring	lock washer	rondelle-ressort
			190	N1042	Sechskantmutter	hex. nut	écrou
			200	80550	Kunststoffrohr	plastic tube	tuyau en plastique
			210	N22359	Schnappschelle	clamp	collier

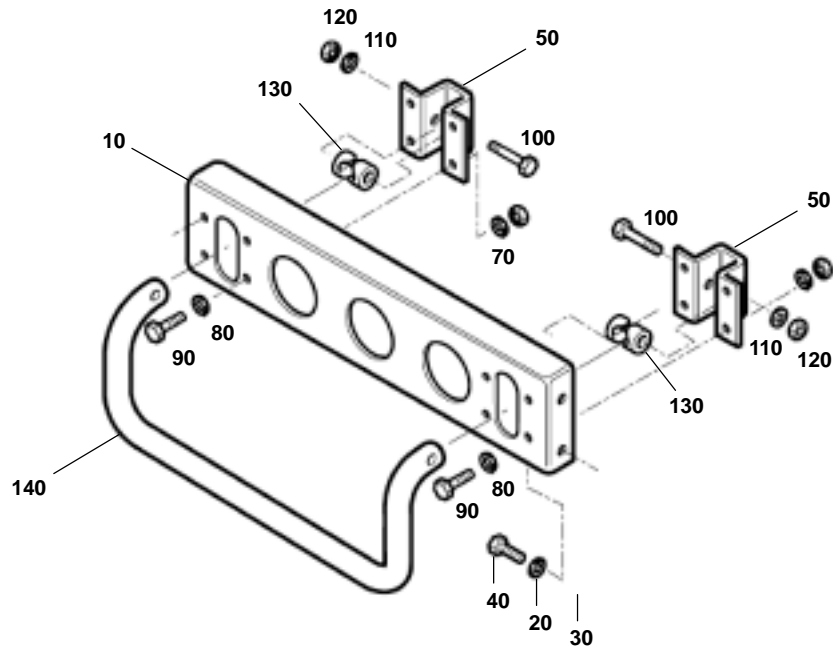
			10/10	79854-01	Schwingrahmen	frame	châssis amortisseur
			10/20	79854-02	Versteifung	support	renfort
			10/60	N58	Scheibe	washer	rondelle
			10/70	N108	Federring	lock washer	rondelle-ressort
			10/80	N19548	Zylinderschraube	allen screw	vis allen

 Wartungssätze
 Maintenance sets
 Kits d'entretien

 Bildtafel
 Figure
 Planche

 79959
 79959
 79959

 Griff kpl.
 Handle assy.
 Poignée cpl.

TM320-22b

Klasse/ Class/ Classe			Pos.	Bestell-Nr. Part No. No. de cde.	Benennung	Designation	Dénomination
a	b	c					
			10	79954	Griffhalterung	handle bracket	fixation de poignée
			20	N108	Federring	lock washer	rondelle-ressort
			30	N58	Scheibe	washer	rondelle
			40	N19548	Zylinderschraube	allen screw	vis allen
			50	79955	Griff-Drehgelenk	hinge	charnière
			70	N108	Federring	lock washer	rondelle-ressort
			80	N58	Scheibe	washer	rondelle
			90	N19548	Zylinderschraube	allen screw	vis allen
			100	N19555	Zylinderschraube	allen screw	vis allen
			110	N58	Scheibe	washer	rondelle
			120	N370	Sechskantmutter	hex nut	écrou
			130	N26381	Sattelscheibe	plastic spacer	entretoise en plastique
			140	79956	Griffrohr	handle bar	tube de poignée

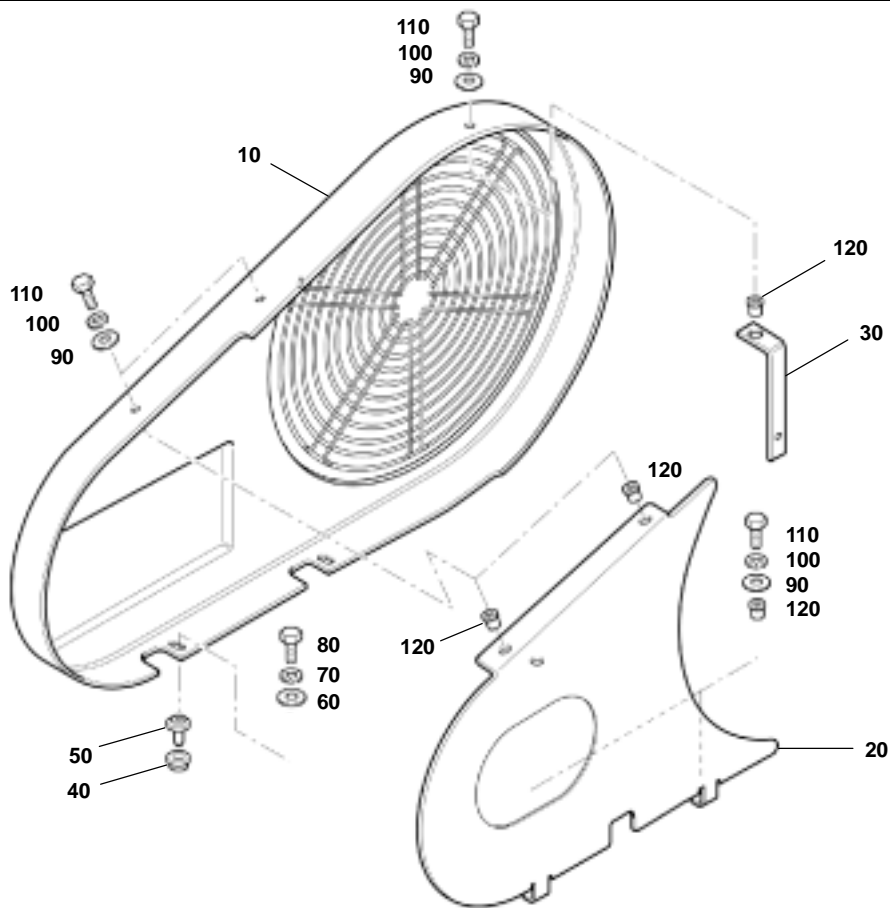



 Wartungssätze
 Maintenance sets
 Kits d'entretien

Bildtafel **80584** **Riemenschutz kpl.**
Figure **80584** **V-belt cover assy.**
Planche **80584** **Carter de courroie cpl.**

TM320-22c

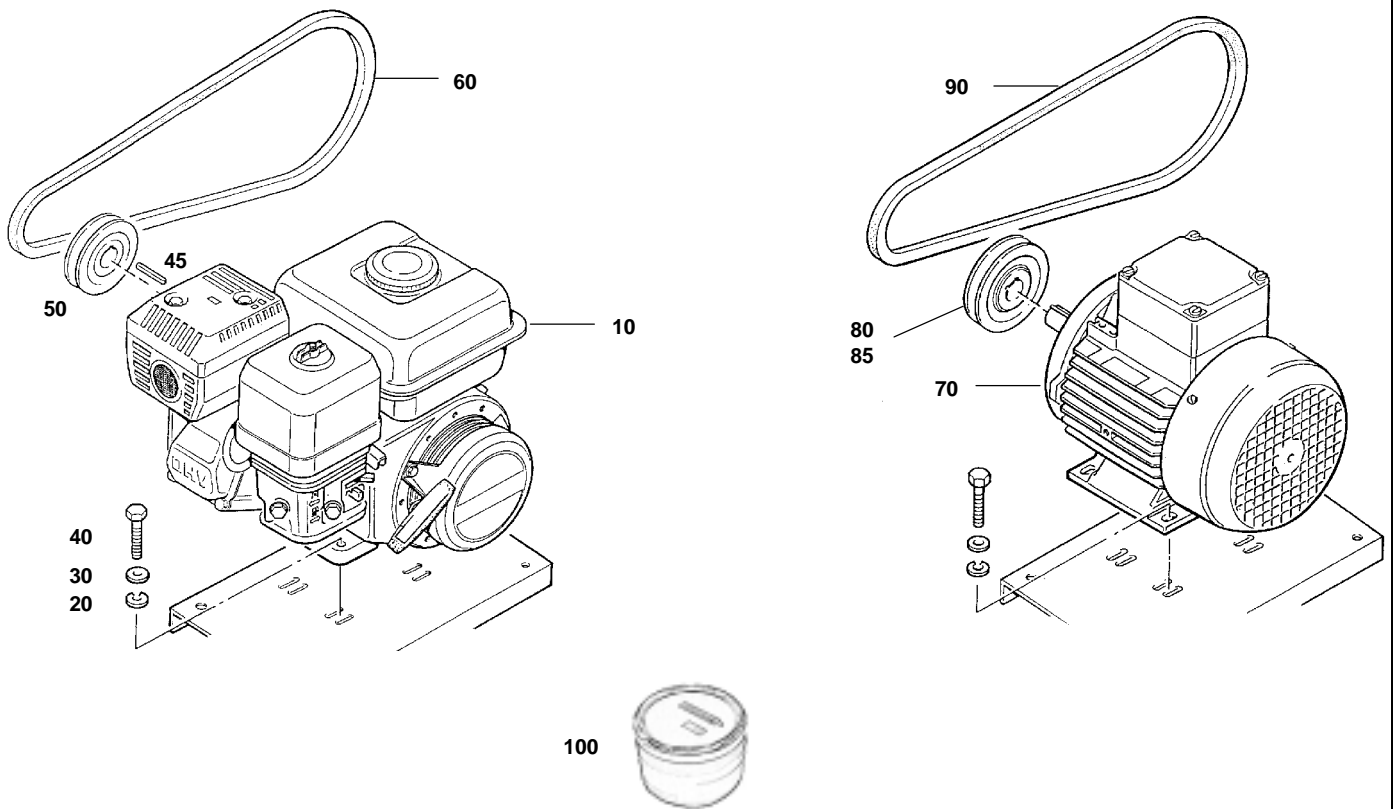
Klasse/ Class/ Classe			Pos.	Bestell-Nr. Part No. No. de cde.	Benennung	Designation	Dénomination
a	b	c					
			10	79978-S01	Riemenschutz m Gitter	v-belt cover with grid	carter de courroie avec grille
			20	79977	Riemenschutz innen	v-belt cover, inner	carter de courroie, intérieur
			30	80271	Halterung	bracket	fixation
			40	N26454	Buchse	bushing	manchon
			50	80501	Stift	pin	goupille
			60	N2863	Scheibe, groß	washer, large	rondelle, large
			65	N2949	Scheibe	washer	rondelle
			70	N635	Federring	lock washer	rondelle-ressort
			80	N3989	Sechskantschraube	hex screw	vis
			90	N2863	Scheibe	washer	rondelle
			100	N100	Federring	lock washer	rondelle-ressort
			110	N19535	Zylinderschraube	allen screw	vis allen
			120	N26455	Mutter, Silentblock	nut, shock mount	écrou, silentbloc



 Wartungssätze
 Maintenance sets
 Kits d'entretien

Baugruppe 80444
Assembly 80444
Assemblage 80444

Antriebsmotoren und Zubehör
Driving motors and accessories
Moteurs d'entraînement et accessoires
TM320-23

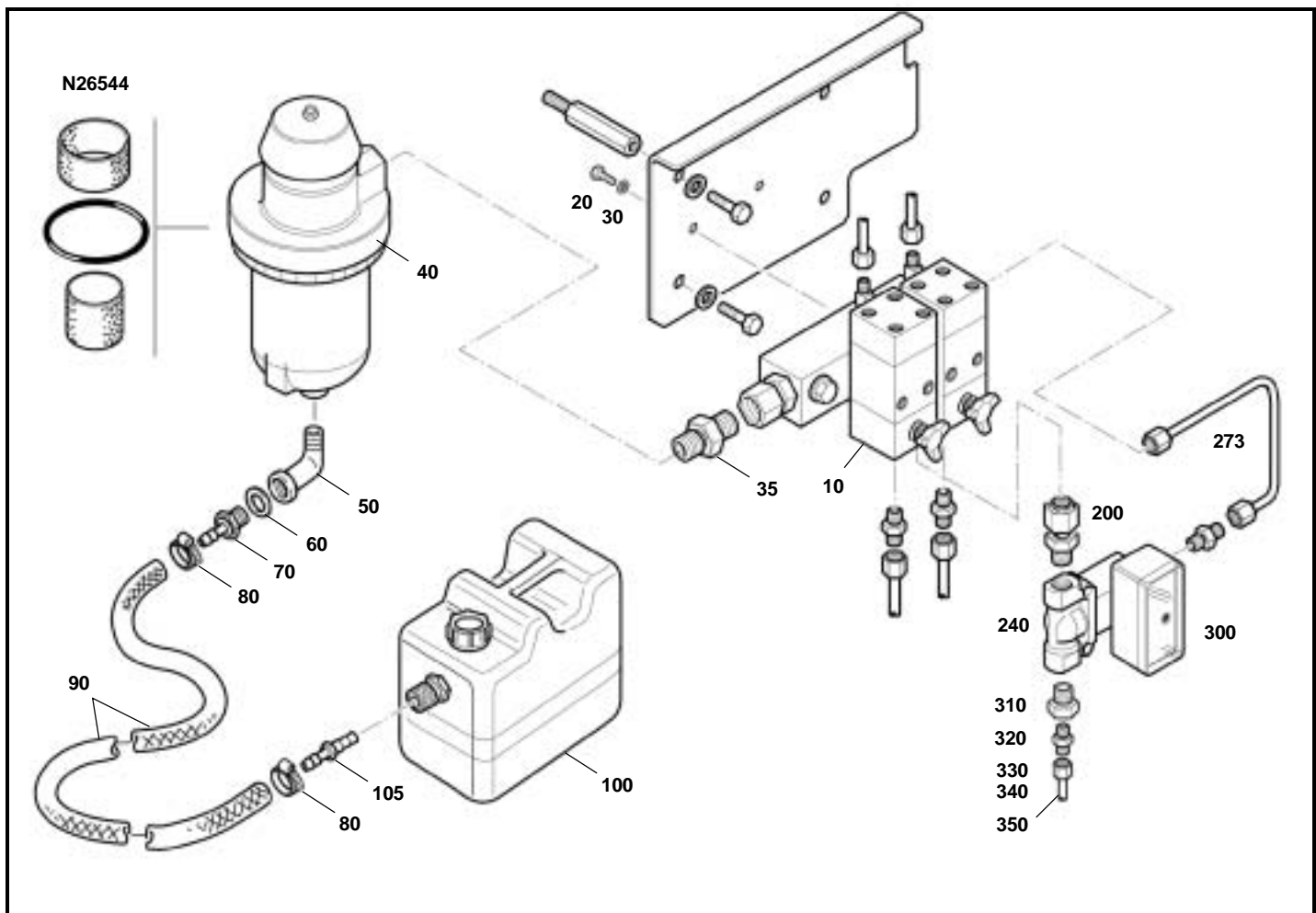
Klasse/ Class/ Classe			Pos.	Bestell-Nr. Part No. No. de cde.	Benennung	Designation	Dénomination
a	b	c					
			10	N26136	Benzinmotor	petrol engine	moteur à essence
			20	N58	Scheibe	washer	rondelle
			30	N108	Federring	spring washer	rondelle-ressort
			40	N19462	Sechskantschraube	hex. screw	vis six pans
			45	80741	Paßfeder	feather key	clavette
			50	80276	Keilriemenscheibe (D=180 mm)	v-belt pulley (D=180 mm)	poulie (D=180 mm)
			60	N2598	Keilriemen (L=1932 mm)	v-belt (L=1932 mm)	courroie trapézoïdale (L=1932 mm)
			70	N25462	Drehstrommotor	3 phase motor	moteur triphasé
			80	N18496	Keilriemenscheibe (D=224 mm)	v-belt pulley (D=224 mm)	poulie (D=224 mm)
			85	N26327	Keilriemenscheibe (D=190 mm)	v-belt pulley (D=190 mm)	poulie (D=190 mm)
			90	N18841	Keilriemen (L=1957 mm)	V-belt (L=1957 mm)	courroie (L=1957 mm)
			100	N26400	Betriebsstundenzähler	time totalizer	compteur horaire



Wartungssätze
 Maintenance sets
 Kits d'entretien

Baugruppe 80589 **Kondensatablaßautomatik kpl. (Zusatzausstattung)**
Assembly 80589 **Automatic condensate drain (optional extra)**
Assemblage 80589 **Purge automatique des condensats (optionnelle)**

TM320-24

Klasse/ Class/ Classe			Pos.	Bestell-Nr. Part No. No. de cde.	Benennung	Designation	Dénomination
a	b	c					
			10	80571	Kondensat-Ablaßautomatik	automatic condensate drain	purge automatique des condensats
			20	N19534	Zylinderschraube	allen screw	vis allen
			30	N100	Federring	spring washer	rondelle-ressort
			35	N20098	G-Einschraubstutzen	straight male connector	raccord droit mâle
			40	80574	Schalldämpfer-Filter	silencer-filter	silencieux-filtre
			40a	N26544	Wartungssatz zu 40	maintenance kit for 40	kit d'entretien pour 40
			50	N1855	Winkel	elbow	coude
			60	N293	Dichtring	gasket	joint
			70	N23873	Schlauchtülle	hose nozzle	raccord de tuyau
			80	N7454	Schlauchschelle	hose clamp	collier de serrage
			90	N19939	Schlauch	PVC hose	PVC tuyau
			100	075354	Kondensatbehälter	condensate collector	réservoir à condensats
			105	N24631	Stecker m. Schlauchtülle	plug	raccord
			200	N4502	G-Einschraubstutzen	straight male connector	raccord droit mâle
			240	N16381	Magnetventil	2/2-way solenoid valve	électrovanne 2/2 voies
			270	64010	Verschraubung	coupling	raccord
			271	N3663	Schneidring	cutting ring 6L/S	rondelle de matrice
			272	N7430	Überwurfmutter	screw cap	écrou-chapeau
			273	N3616	Rohr	stainless steel tube 6x1	tuyau en acier inox 6x1
			300	N22584	Taktgeber	timer	minuterie
			310	N20112	Reduzierstutzen	fitting	raccord
			320	N20065	G-Einschraubstutzen	Straight male stud	raccord droit mâle
			330	N3609	Schneidring	cutting ring	rondelle de matrice
			340	N1049	Überwurfmutter	screw cap	écrou-chapeau
			350	N3618	Rohr	stainless steel tube 8x1	tuyau en acier inox 8x1
			360	N1049	Überwurfmutter	screw cap	écrou-chapeau
			370	N3609	Schneidring	cutting ring	rondelle de matrice
			380	N20152	Einst. W-Stutzen	adjustable W-coupling	raccord coudé orientable
			400	N20065	G-Einschraubstutzen	Straight male stud	raccord droit mâle
			410	N3609	Schneidring	cutting ring	rondelle de matrice
			420	N1049	Überwurfmutter	screw cap	écrou-chapeau

*

**

Meterware
Bei Bestellung Spannung
und Frequenz angeben

Piece goods; specify length on order
Please specify voltage
and frequency on order

Marchandise au mètre; indiquer la longueur à la commande
Veuillez indiquer tension et fréquence à la commande

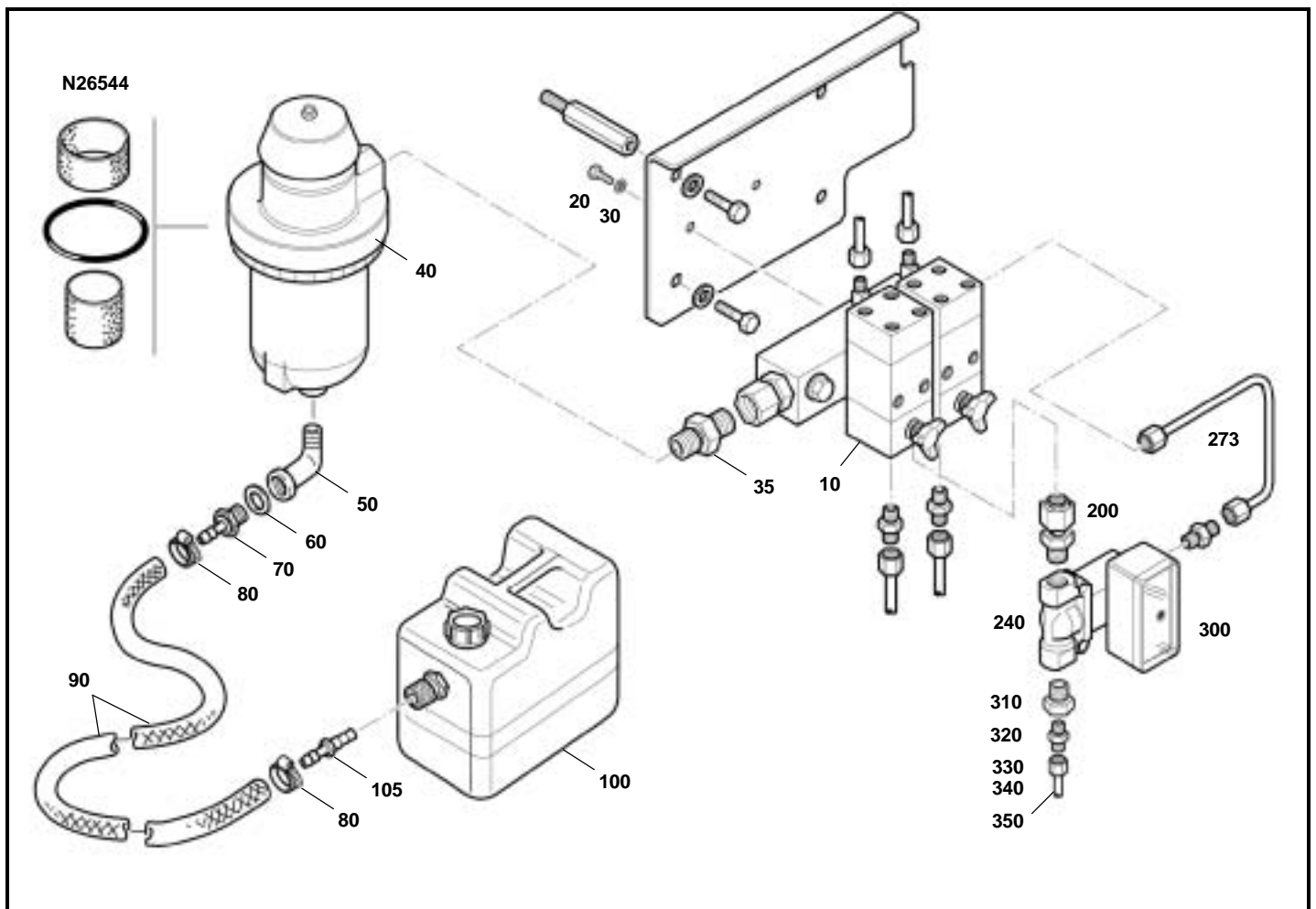



Wartungssätze
 Maintenance sets
 Kits d'entretien

Baugruppe 80589 **Kondensatablaufautomatik kpl. (Zusatzausstattung)**
Assembly 80589 **Automatic condensate drain (optional extra)**
Assemblage 80589 **Purge automatique des condensats (optionnelle)**

TM320-24

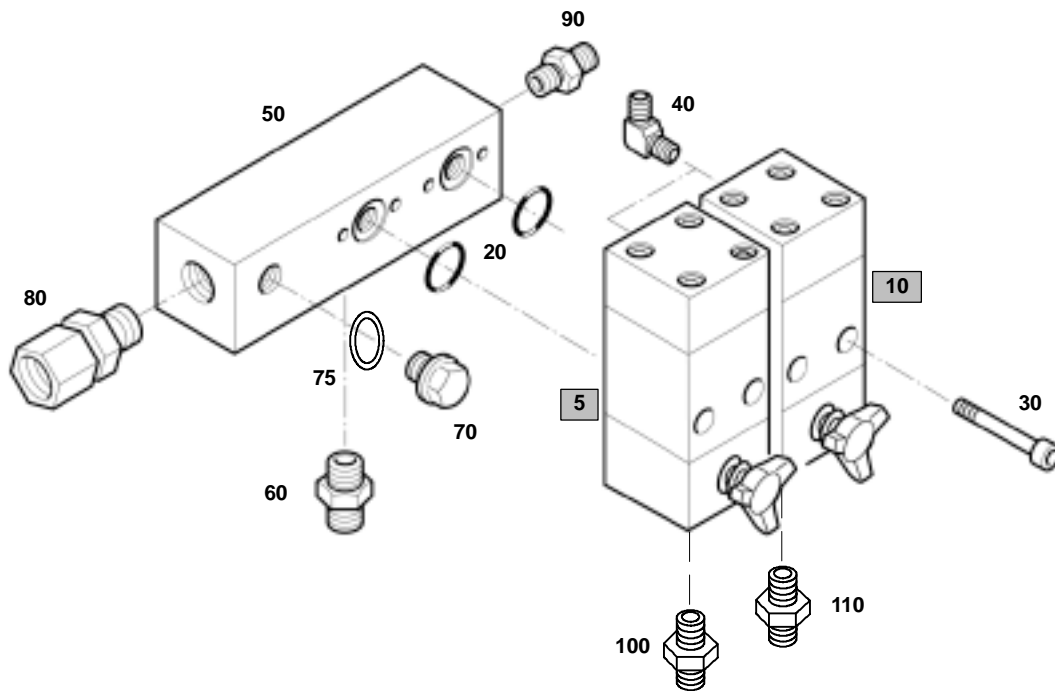
Klasse/ Class/ Classe			Pos.	Bestell-Nr. Part No. No. de cde.	Benennung	Designation	Dénomination
a	b	c					
			430	N3618	Rohr	stainless steel tube 8x1	tuyau en acier inox 8x1
			440	N1049	Überwurfmutter	screw cap	écrou-chapeau
			450	N3609	Schneidring	cutting ring	rondelle de matrice
			460	N20152	Einst. W-Stutzen	adjustable W-coupling	raccord coudé orientable
			470	N20287	G-Einschraubstutzen	union	raccord
			480	N3609	Schneidring	cutting ring	rondelle de matrice
			490	N3608	Überwurfmutter	screw cap	écrou-chapeau
			500	N3619	Rohr	stainless steel tube 8x1.5	tuyau en acier inox 8x1.5
			510	N3608	Überwurfmutter	screw cap	écrou-chapeau
			520	N3609	Schneidring	cutting ring	rondelle de matrice
			530	N20404	G-Einschraubstutzen	Screwed socket	raccord
			540	N3663	Schneidring	cutting ring 6L/S	rondelle de matrice
			550	N7430	Überwurfmutter	screw cap	écrou-chapeau
			560	N3616	Rohr	stainless steel tube 6x1	tuyau en acier inox 6x1
			570	N3663	Schneidring	cutting ring 6L/S	rondelle de matrice
			580	N7430	Überwurfmutter	screw cap	écrou-chapeau
			590	N3616	Rohr	stainless steel tube 6x1	tuyau en acier inox 6x1
			600	80747	Gleichrichter	rectifier	redresseur
			610	80755	Halterung	bracket	fixation
			620	80851	Halterung	bracket	fixation

 Wartungssätze
 Maintenance sets
 Kits d'entretien

Baugruppe 80571
Assembly 80571
Assemblage 80571

Kondensatablaßventil kpl. (Zusatzausstattung)
Condensate drain valve assy. (optional extra)
Soupape de purge des condensats cpl. (optionnelle)
TM320-24a

Klasse/ Class/ Classe			Pos.	Bestell-Nr. Part No. No. de cde.	Benennung	Designation	Dénomination
a	b	c					
			5	064008	Kondensatventil	condensate drain valve	soupape de purge des condensats
			10	064009	Kondensatventil	condensate drain valve	soupape de purge des condensats
			20	N638	O-Ring	o-ring	joint torique
			30	N19538	Zylinderschraube	allen screw	vis à six pans creux
			40	N20003	W-Einschraubstutzen	male elbow	coude
			50	79969	Sammelleiste	manifold	collecteur
			60	N20018	G-Einschraubstutzen	screwed socket	raccord
			70	N52	Verschlußschraube	plug	bouchon fileté
			75	N1316	Dichtring	gasket	joint
			80	N15952	G-Einschraubstutzen	straight male connector	raccord
			90	N20237	G-Einschraubstutzen	straight male connector	raccord
			100	78791	Drosselverschraubung	choking connector	raccord d'étranglement
			110	N20065	G-Einschraubstutzen	straight male connector	raccord

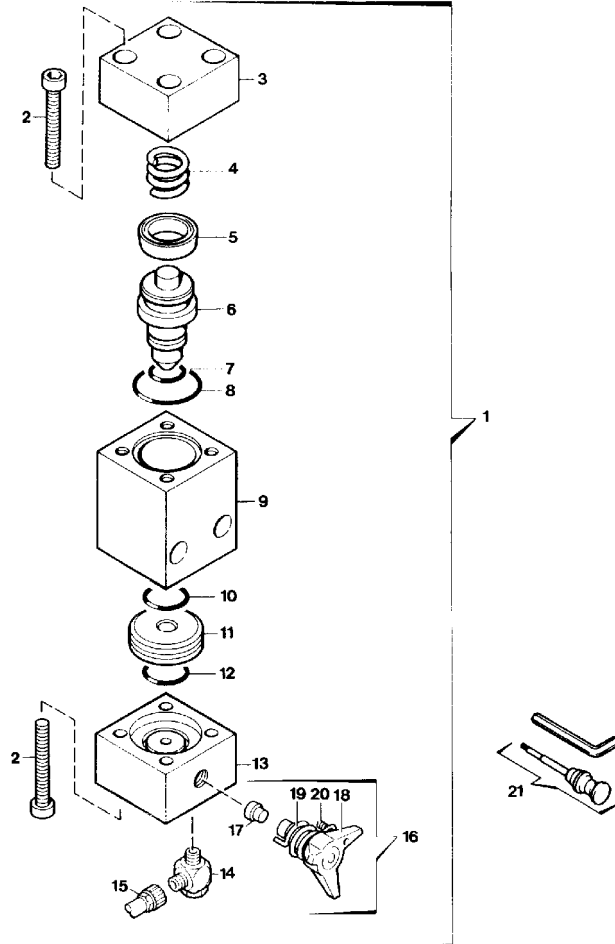

064008/08/98



 Wartungssätze
 Maintenance kits
 Kits d'entretien

 Baugruppe 064008
 Assembly 064008
 Assemblage 064008

 Kondensatablaßventil
 Condensate drain valve
 Soupape de purge

TM320-24b

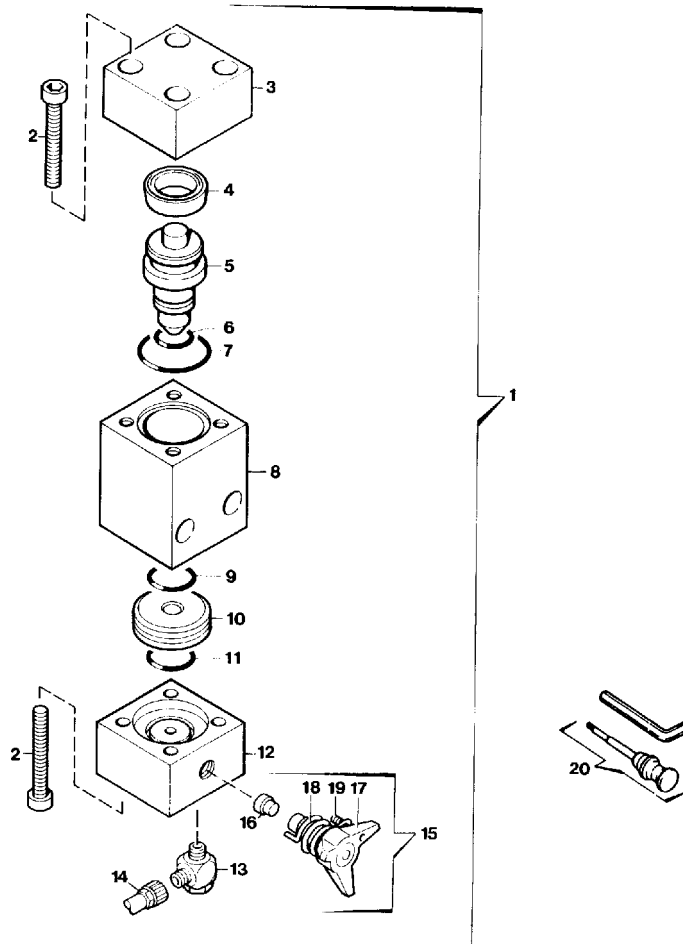
Klasse/ Class/ Classe			Pos.	Bestell-Nr. Part No. No. de cde.	Anz. Qty. Qté.	Benennung	Designation	Dénomination
a	b	c						
			1	064008	1	Kondensatablaßventil	Condensate drain valve	Soupape de purge
			2	N19536	8	Innensechskantschraube	Allen screw	Vis à six pans creux
			3	64000	1	Kopfteil	Top flange	Bride supérieure
			4	64011	1	Feder	Spring	Ressort
	X		5	N16269	1	Nutring	Sealing ring	Bague d'étanchéité
		X	6	64003	1	Kolben	Piston	Piston
	X		7	N638	1	O-Ring	O-ring	Joint torique
	X		8	N4881	1	O-Ring	O-ring	Joint torique
			9	64001	1	Mittelteil	Valve body	Corps de soupape
	X		10	N2507	1	O-Ring	O-ring	Joint torique
	X		11	64005	1	Ventilsitz	Valve seat	Siège de soupape
	X		12	N4496	1	O-Ring	O-ring	Joint torique
			13	64002	1	Fußteil	Base flange	Bride inférieure
			14	N16334	1	Schwenkverschraubung	Adjustable male branch T	Raccord en T orientable
			15	N15088	1	Schlauch	Hose	Tuyau
			16	065500	1	Knebelschraube kpl.	Drain tap assy.	Robinet cpl.
			17	64498	1	Dichtung	Gasket	Joint
			18	11392	1	Knebelschraube	Drain tap	Robinet
			19	65310	1	Schenkelfeder	Spring	Ressort à broches
			20	N16947	1	Gewindestift	Stud	Vis sans tête
			21	067458	1	Werkzeugsatz f. Knebelschraube	Tool set for drain tap	Jeu d'outils pour robinet



064009/08/98

 Wartungssätze
 Maintenance kits
 Kits d'entretien

Baugruppe	064009	Kondensatablaßventil
Assembly	064009	Condensate drain valve
Assemblage	064009	Soupape de purge

TM320-24c

Klasse/ Class/ Classe			Pos.	Bestell-Nr. Part No. No. de cde.	Anz. Qty. Qté.	Benennung	Designation	Dénomination
a	b	c						
			1	064009	1	Kondensatablaßventil	Condensate drain valve	Soupape de purge
			2	N19536	8	Innensechskantschraube	Allen screw	Vis à six pans creux
			3	64000	1	Kopfteil	Top flange	Bride supérieure
	X		4	N16269	1	Nutring	Sealing ring	Bague d'étanchéité
		X	5	64003	1	Kolben	Piston	Piston
	X		6	N638	1	O-Ring	O-ring	Joint torique
	X		7	N4881	1	O-Ring	O-ring	Joint torique
			8	64001	1	Mittelteil	Valve body	Corps de soupape
	X		9	N2507	1	O-Ring	O-ring	Joint torique
	X		10	64005	1	Ventilsitz	Valve seat	Siège de soupape
	X		11	N4496	1	O-Ring	O-ring	Joint torique
			12	64002	1	Fußteil	Base flange	Bride inférieure
			13	N16334	1	Schwenkverschraubung	Adjustable coupling	Raccord orientable
			14	N15088	1	Schlauch	Hose	Tuyau
			15	065500	1	Knebelschraube kpl.	Drain tap assy.	Robinet cpl.
			16	64498	1	Dichtung	Gasket	Joint
			17	11392	1	Knebelschraube	Drain tap	Robinet
			18	65310	1	Schenkelfeder	Spring	Ressort à broches
			19	N16947	1	Gewindestift	Stud	Vis sans tête
			20	067458	1	Werkzeugsatz f. Knebelschraube	Tool set for drain tap	Jeu d'outils pour robinet

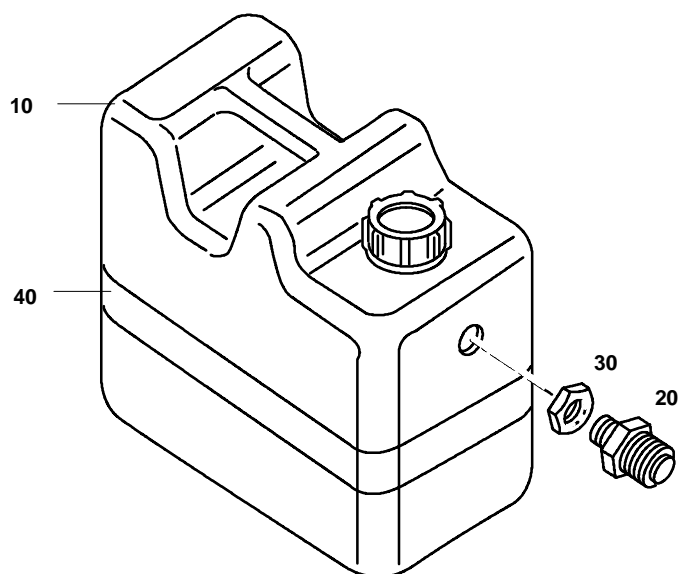

Wartungssätze
 Maintenance kits
 Kits d'entretien

Baugruppe 075354 Sammelbehälter
 Assembly 075354 Collector tank
 Assemblage 075354 Réservoir collecteur

TM320-24d

Klasse/ Class/ Classe			Pos.	Bestell-Nr. Part No. No. de cde.	Anz. Qty. Qté.	Benennung	Designation	Dénomination
a	b	c						
			10	75355	1	Kanister	tank	bidon
			20	N17179	1	Kupplung	coupling	raccord
			30	N17448	1	Gegenmutter	nut	écrou
			40	N17184	mm	Isolierband	insulating tape	bande isolante

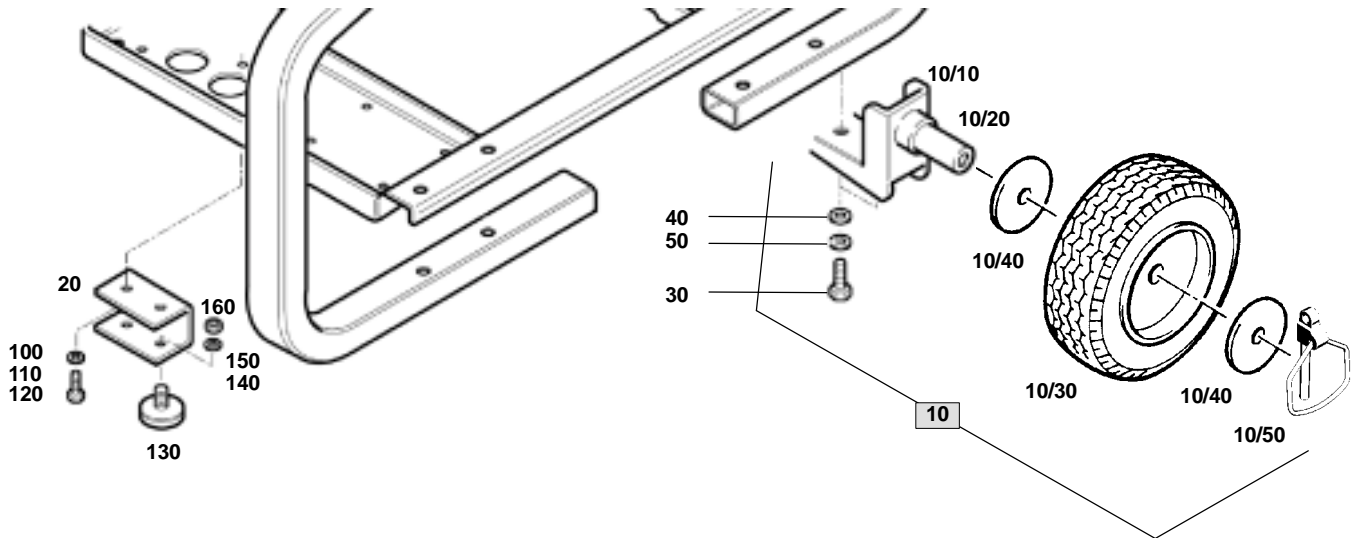

 Wartungssätze
 Maintenance sets
 Kits d'entretien

Baugruppe 80775
Assembly 80775
Assemblage 80775

Fahrsatz (Zusatzausstattung)
Undercarriage (optional extra)
Chariot (option)
TM320-25

Klasse/ Class/ Classe			Pos.	Bestell-Nr. Part No. No. de cde.	Benennung	Designation	Dénomination
a	b	c					
			10	80769	Fahrsatz	Undercarriage	Chariot
			20	80769-03	Halterung	bracket	fixation
			30	N19496	Sechskantschraube	screw	vis
			40	N102	Scheibe	washer	rondelle
			50	N100	Federring	spring washer	rondelle-ressort
			100	N58	Scheibe	washer	rondelle
			110	N108	Federring	spring washer	rondelle-ressort
			120	N19506	Sechskantschraube	screw	vis
			130	N1547	Schwingmetall	vibration isolator	silent-bloc
			140	N16	Scheibe	washer	rondelle
			150	N8999	Federring	lock washer	rondelle élastique
			160	N644	Sechskantmutter	hexagon nut self-locking	écrou hexagonal auto-freinant

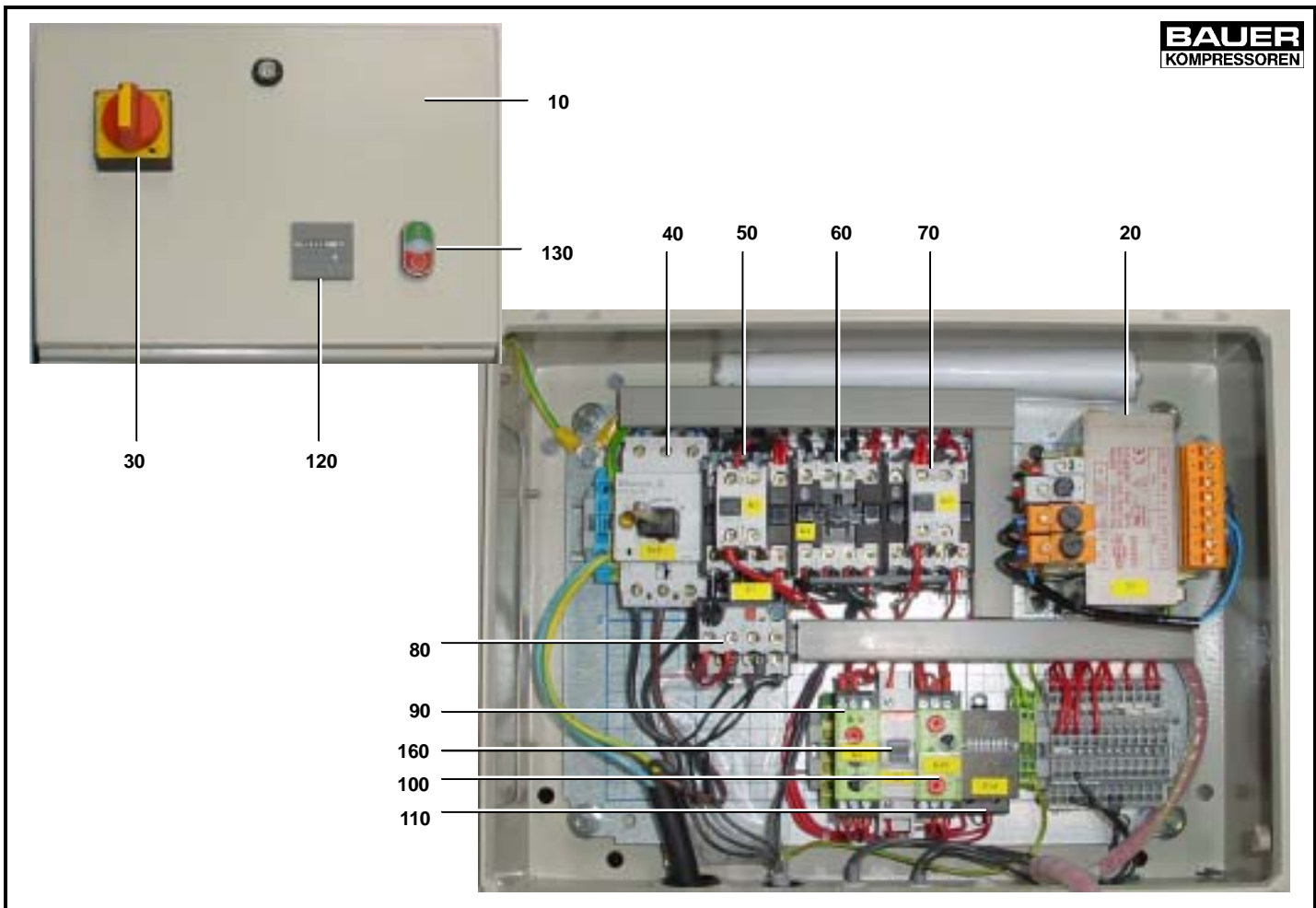
			10/10	80769-04*	Querstrebe	cross arm	
			10/20	80769-02*	Achse	axle	axe
			10/30	N3772	Rad	wheel	roue
			10/40	N1222	Scheibe	washer	rondelle
			10/50	N26639	Splint	split	goupille

 Wartungssätze
 Maintenance sets
 Kits d'entretien

Baugruppe 80752
Assembly 80752
Assemblage 80752

Elektr. Steuerung (Zusatzausstattung)
Electric control system (optional extra)
Commande électrique (option)
TM320-26

Klasse/ Class/ Classe			Pos.	Bestell-Nr. Part No. No. de cde.	Benennung	Designation	Dénomination
a	b	c					
			10	80744	Gehäuse	switch box	boîtier
			20	N26301	Transformator T1	transformer T1	transformateur T1
			30	N26569	Drehantrieb f. Leistungsschalter	actuator for power switch	poignée d'interrupteur
			40	N26570	Leistungsschalter F10	power switch F10	interrupteur de puissance F10
			50	N26571	Motorschütz K1	motor relay K1	disjoncteur moteur K1
			60	N26572	Motorschütz K2	motor relay K2	disjoncteur moteur K2
			70	N26573	Motorschütz K3	motor relay K3	disjoncteur moteur K3
			80	N26574	Überlastrelais F1	overload relay F1	relais de surcharge F1
			90	N16201	Zeitrelais K4	time relay K4	temporisateur K4
			100	N16202	Taktgeber K10	timer K10	minuterie K10
			110	N19096	Zyklenzähler P14	cycle counter P14	compteur de cycles P14
			120	N23853	Betriebsstundenzähler	hourmeter	compteur horaire
			130	N26308	Tastschalter S1	pushbutton switch S1	interrupteur S1
			160	N16206	Service-Schalter S3	service switch S3	interrupteur de service S3

